

tyco

Fire Protection Products

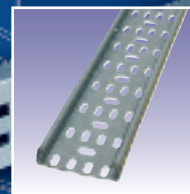

Cable Management Solutions

a vital part of your world

ENGLISH/DUTCH/FRENCH/GERMAN/NORWEGIAN/SWEDISH

GB **P** **Standard finish:**

- 1** Self colour
- 2** Pre galvanised
- 3** Hot dip galvanised
(EN ISO 1461:1999)
- 4** Stainless steel 316L (A4)
- 5** Electro zinc plated
- 6** Deltatone
(>550 H. ASTM B 117 94)
- 7** Zinc painted

D **P** **Standardausführungen:**

- 1** Walzblank
- 2** Feuerverzinkt nach dem Sendzimir-
verzinkungsverfahren (Z 275)
- 3** Feuerverzinkt nach dem Tauchverfahren
(EN ISO 1461:1999)
- 4** Edelstahl W. 1.4404/1.4571 (A4)
- 5** Galvanisch verzinkt
- 6** Deltatone
(>550 H. ASTM B 117 94)
- 7** Zink Anstrich

NL **P** **Standaard afwerkingen:**

- 1** Blank onbewerkt staal
- 2** Sendzimir verzinkt plaatstaal
- 3** Thermisch verzinkt na fabricage
(EN ISO 1461:1999)
- 4** Roestvrij staal
(AISI 316L, nr 1.4404 (A4))
- 5** Electrolytisch verzinkt
- 6** Deltatone
(>550 H. ASTM B 117 94)
- 7** Zink primer

N **P** **Standard materialkvaliteter:**

- 1** Ubehandlet
- 2** Pregalvaniseret
- 3** Varmforsinket
(EN ISO 1461:1999)
- 4** Syrefat stål 316L (A4)
- 5** Elforsinket
- 6** Deltatone
(>550 H. ASTM B 117 94)
- 7** Zink malt

F **P** **Finition standard:**

- 1** Acier brut
- 2** Acier galvanisé Sendzimir (Z 275)
- 3** Acier galvanisé à chaud après fabrication
(EN ISO 1461:1999)
- 4** Acier inoxydable AISI 316L (A4)
- 5** Electro zingué
- 6** Deltatone
(>550 H. ASTM B 117 94)
- 7** Peinture en zinc

S **P** **Materialbeskrivning:**

- 1** Obehandlat
- 2** Förgalvaniserat
- 3** Varmgalvaniserat
(EN ISO 1461:1999)
- 4** Rostfritt stål 316L (A4)
- 5** Elförzinkat
- 6** Deltatone
(>550 H. ASTM B 117 94)
- 7** Zinkfärg

- GB Cable tray
- NL Kabelgoot
- F Chemin de câbles
- D Kabelrinnen
- N Kabelrenne
- S System för kabelrännor

Type L  P1.002

Type M  P1.006

Type H  P1.010

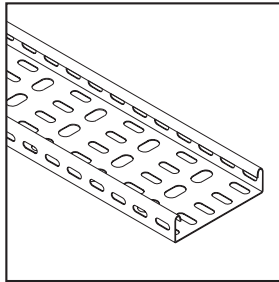

- GB Support systems
- NL Ondersteuningen
- F Systèmes de supportage
- D Unistrut Schienenbefestigungssystem
- N Understøttelse
- S Unistrut opphængningssystem

 P6.001

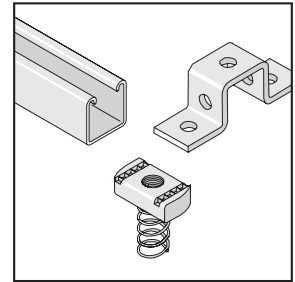

- GB Basket tray
- NL Draadgoot
- F Chemins de câbles en fil
- D Gitterrinnen
- N Kabelkurv
- S System för nätrännor

 P2.001

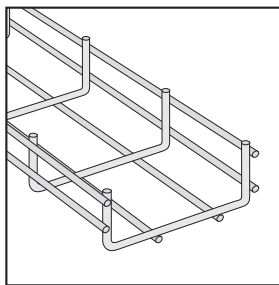

- GB Cable clamps
- NL Kabelbevestigingen
- F Collier pour câbles
- D Kabelschellen
- N Kabelklammer
- S Klammer för kabelrör

 P7.001

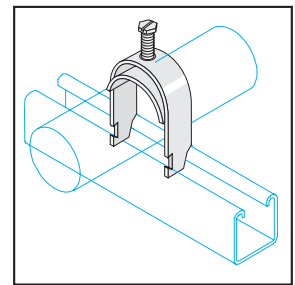

- GB Cable ladder
- NL Kabelladder
- F Echelles à câbles
- D Kabelleitern
- N Kabelstige
- S System för kabelstegar

 P3.001

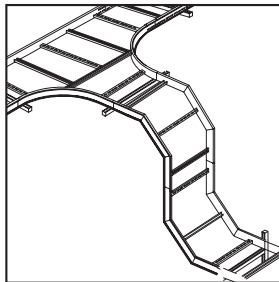

- GB Fixings
- NL Bouten, moeren & ringen
- F Fixations
- D Befestigungsmaterial
- N Festemateriell
- S Bolt och mutter

 P8.001

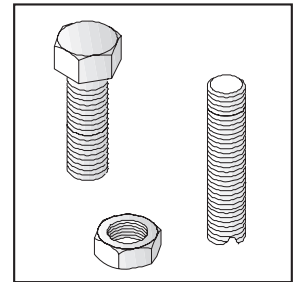

- GB Marine ladder
- NL Scheepsladder
- F Echelles marine
- D Kabelleitern nach Marinenorm
- N Skipsstige
- S System för marinsteigar

 P4.000

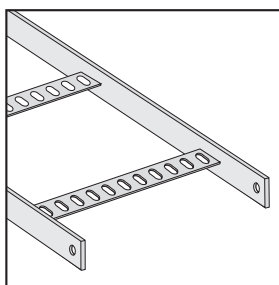

- GB Index
- NL Index
- F Index
- D Index
- N Index
- S Inehåll

 P9.001

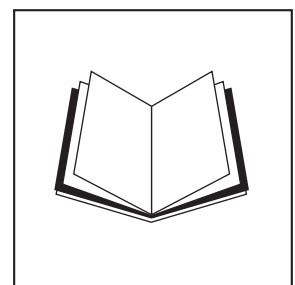

- GB Tube system
- NL Buissysteem
- F Tube à câbles
- D Leitungsschutzrohrsystem
- N Rørsystem
- S Tube kabelskyddssystem

 P5.001

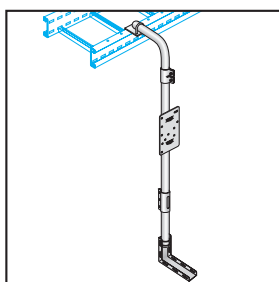

CABLE TRAY L

GB Light duty cabletray

NL Lichte kabelgoot

F Chemins de câbles série L

D Kabelrinnen L

N Lett kabelrenne type L

S Lättvikts kabelränna

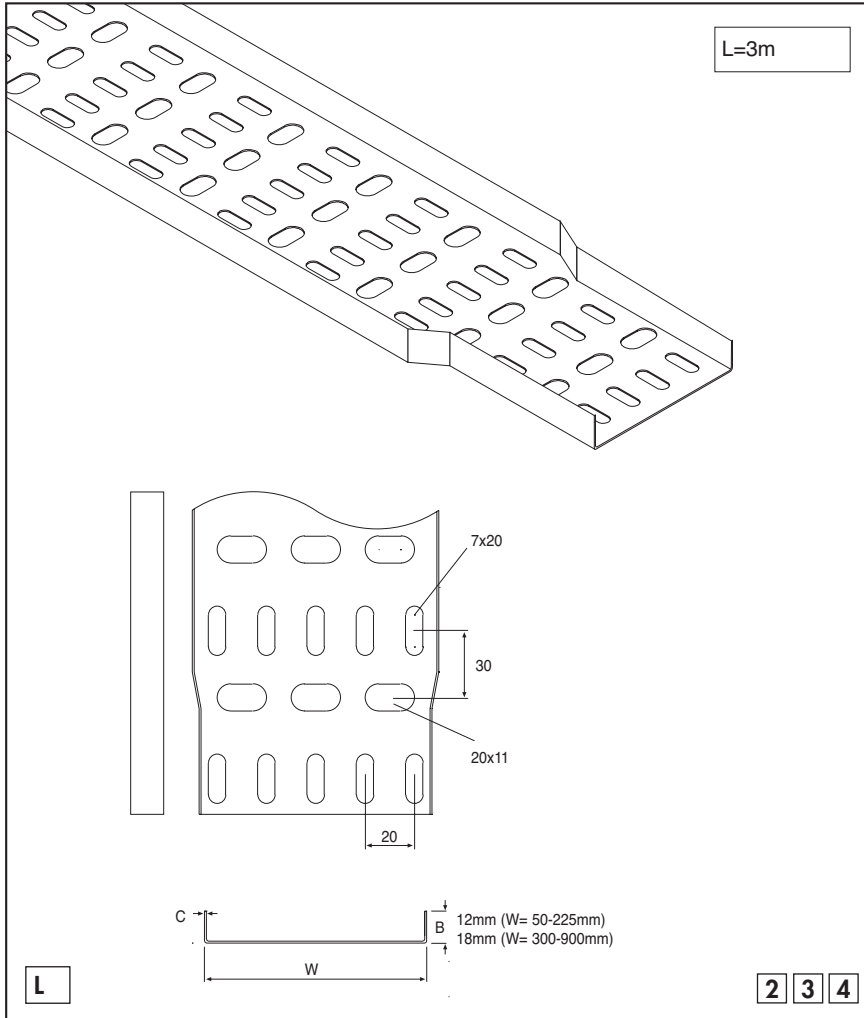

Art. Nr.	W mm	B mm	C mm	⚖️
LL050/10 P	50	12	0,8	1,77
LL075/10 P	75	12	0,8	2,40
LL100/10 P	100	12	0,8	3,03
LL150/10 P	150	12	0,8	4,29
LL225/10 P	225	12	0,8	6,18
LL300/15 P	300	18	1,2	12,63
LL450/15 P	450	18	1,2	18,25
LL600/20 P	600	18	2,0	30,37
LL750/20 P	750	18	2,0	39,45
LL900/20 P	900	18	2,0	47,01

GB Tray couplers

NL Koppelplaten

F Eclisses

D Rinnenverbinder

N Skjøt

S Sidoskarv

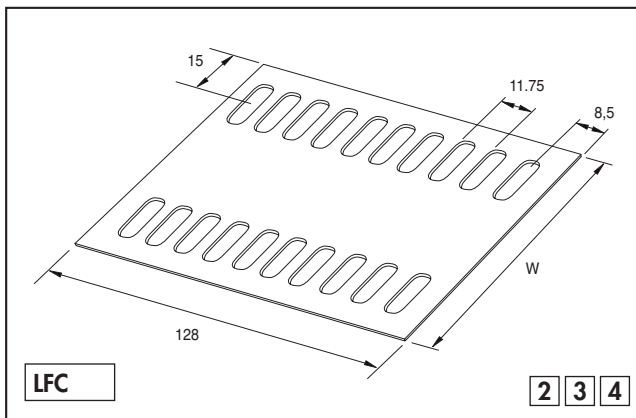

Art. Nr.	W mm	→ ← mm	⚖️
LPF050 P	45	1,5	0,07
LPF075 P	70	1,5	0,11
LPF100 P	95	1,5	0,15
LPF150 P	145	1,5	0,22
LPF225 P	220	1,5	0,32
LPF300 P	295	1,5	0,45
LPF450 P	445	1,5	0,67
LPF600 P	595	1,5	0,90
LPF750 P	745	1,5	1,13
LPF900 P	895	1,5	1,35



CABLE TRAY L

Bogen 90°, T-Stück & Kreuzstück **D**

Bend, T-stykke og kryss **N**

Avgreningar **S**

Flat bend equal tee and equal cross **GB**

Bocht-, T-stuk en kruisstuk **NL**

Coude et croix **F**

Art. Nr. 90°	Art. Nr. 45°	W mm	B		C mm	mm	kg	
			90° mm	45° mm			90°	45°
LB050/90 P	LB050/45 P	50	100	66	74,5	0,8	0,13	0,09
LB075/90 P	LB075/45 P	75	125	91	74,5	0,8	0,20	0,13
LB100/90 P	LB100/45 P	100	150	116	74,5	0,8	0,29	0,19
LB150/90 P	LB150/45 P	150	200	166	74,5	0,8	0,50	0,33
LB225/90 P	LB225/45 P	225	275	238	74,5	0,8	0,93	0,80
LB300/90 P	LB300/45 P	300	350	315	74,5	1,2	1,54	1,00
LB450/90 P	LB450/45 P	450	500	464	74,5	1,2	3,07	2,00
LB600/90 P	LB600/45 P	600	650	615	74,5	1,2	5,13	3,33
LB750/90 P	LB750/45 P	750	800	765	74,5	2,0	7,70	5,00
LB900/90 P	LB900/45 P	900	950	915	74,5	2,0	10,79	7,01

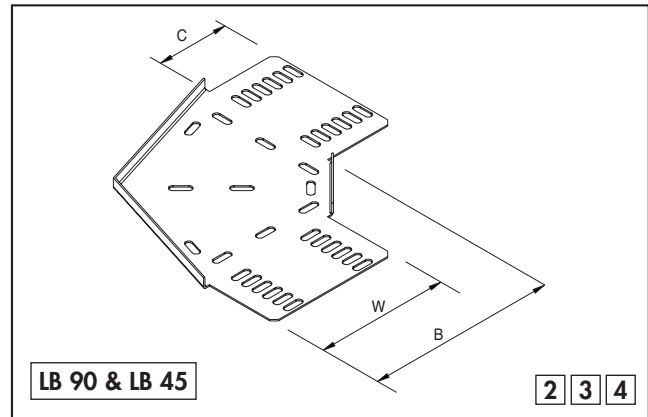

Art. Nr.	W mm	B mm	C mm	mm	kg
LT050 P	50	100	74,5	0,8	0,22
LT075 P	75	125	74,5	0,8	0,28
LT100 P	100	150	74,5	0,8	0,43
LT150 P	150	200	74,5	0,8	0,71
LT225 P	225	275	74,5	0,8	1,26
LT300 P	300	350	74,5	1,2	2,02
LT450 P	450	500	74,5	1,2	3,91
LT600 P	600	650	74,5	1,2	6,42
LT750 P	750	800	74,5	2,0	9,56
LT900 P	900	950	74,5	2,0	13,31

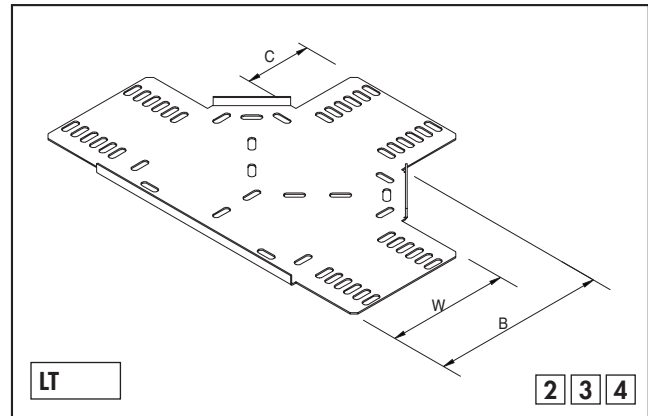

Art. Nr.	W mm	B mm	C mm	mm	kg
LX050 P	50	100	74,5	0,8	0,28
LX075 P	75	125	74,5	0,8	0,39
LX100 P	100	150	74,5	0,8	0,52
LX150 P	150	200	74,5	0,8	0,83
LX225 P	225	275	74,5	0,8	1,43
LX300 P	300	350	74,5	1,2	2,20
LX450 P	450	500	74,5	1,2	4,16
LX600 P	600	650	74,5	1,2	6,75
LX750 P	750	800	74,5	2,0	9,95
LX900 P	900	950	74,5	2,0	13,77

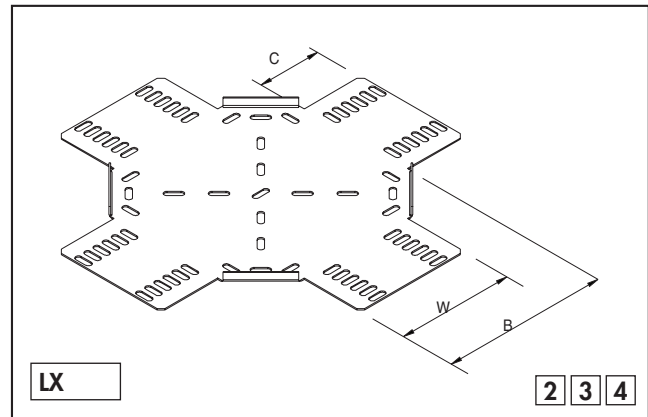

CABLE TRAY L

- GB** Flexible riser
- NL** Flexibele stijg- en vervalstukken
- F** Éléments de raccordement

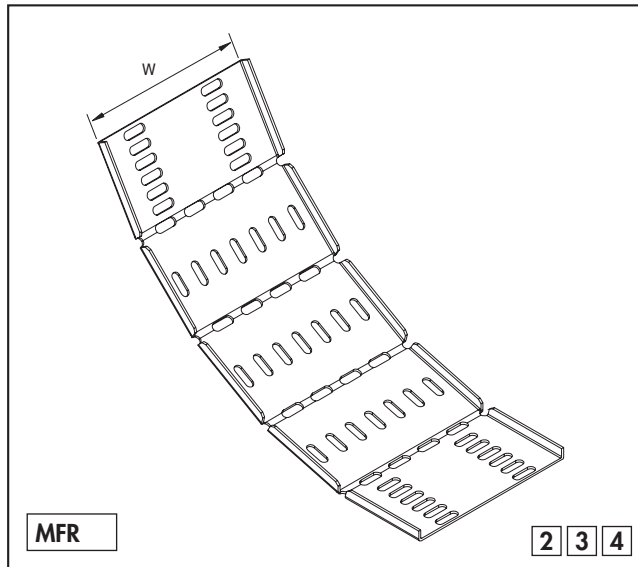

- D** Flexibler Vertikalbogen
- N** Flexibel riser
- S** Flexibel nivåled

Art. Nr.	W mm	± mm	Ⓜ
MFR050 P	50	0,8	0,176
MFR075 P	75	0,8	0,238
MFR100 P	100	0,8	0,304
MFR150 P	150	0,8	0,424
MFR225 P	225	0,8	0,619
MFR300 P	300	1,2	1,188
MFR450 P	450	1,2	1,752
MFR600 P	600	1,2	2,373
MFR750 P	750	2,0	3,190
MFR900 P	900	2,0	4,010

- GB** Used as inside riser:
- D** als Steigestück
- NL** Als stijgstuk:
- N** Brukt som innvendig riser
- F** Exemple de montage:
- S** Invändig höjning

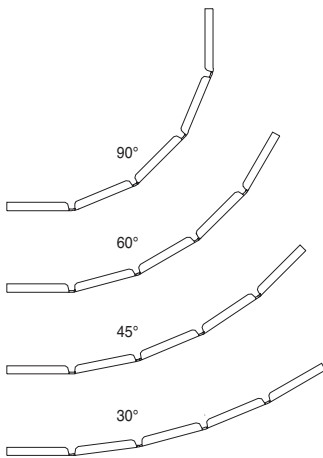

- GB** Used as outside riser:
- D** als Fallstück
- NL** Als vervalstuk:
- N** Brukt som utvendig riser
- F** Exemple de montage:
- S** Utvändig höjning

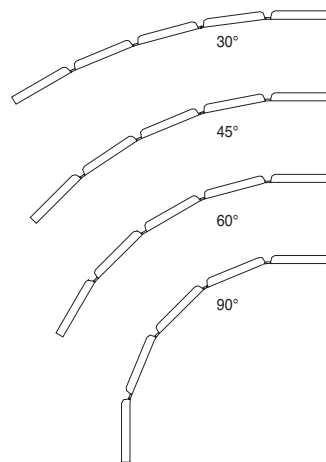



CABLE TRAY L

Reduzierstücke **D**

Reduksjon **N**

Reducering **S**

Cabletray reducer **GB**

Verloopstukken **NL**

Reductions **F**

Art. Nr.	W1 mm	W2 mm	C mm	mm	kg
LS075/050 P	75	50	75	0,8	0,28
LS100/075 P	100	75	75	0,8	0,36
LS100/050 P	100	50	150	0,8	0,33
LS150/100 P	150	100	75	0,8	0,49
LS150/075 P	150	75	150	0,8	0,45
LS150/050 P	150	50	150	0,8	0,41
LS225/150 P	225	150	75	0,8	0,70
LS225/100 P	225	100	150	0,8	0,62
LS225/075 P	225	75	150	0,8	0,57
LS300/225 P	300	225	75	1,2	0,99
LS300/150 P	300	150	150	1,2	0,87
LS300/100 P	300	100	150	1,2	0,79
LS450/300 P	450	300	75	1,2	1,37
LS450/225 P	450	225	150	1,2	1,25
LS450/150 P	450	150	150	1,2	1,14
LS450/100 P	450	100	300	1,2	1,06
LS600/450 P	600	450	75	1,2	1,88
LS600/300 P	600	300	150	1,2	1,64
LS600/225 P	600	225	150	1,2	1,53
LS600/150 P	600	150	225	1,2	1,41
LS750/600 P	750	600	75	2,0	2,39
LS750/450 P	750	450	150	2,0	2,25
LS750/300 P	750	300	150	2,0	2,13
LS750/225 P	750	225	300	2,0	2,00
LS900/750 P	900	750	75	2,0	2,89
LS900/600 P	900	600	150	2,0	2,65
LS900/450 P	900	450	150	2,0	2,42
LS900/300 P	900	300	300	2,0	2,19

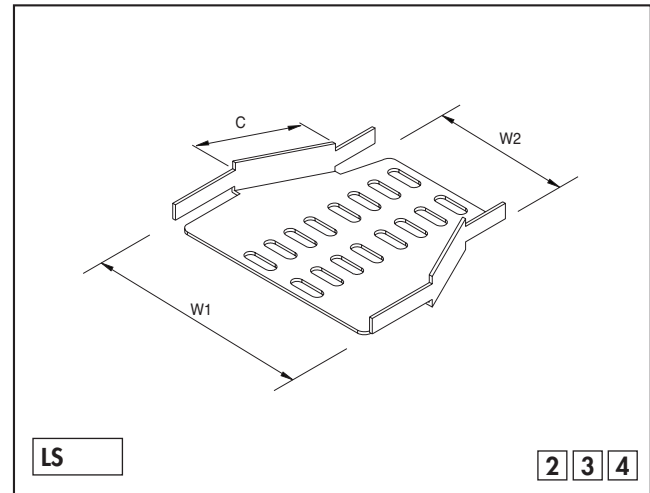

CABLE TRAY M-25 MM

- GB** Medium duty return flange cabletray
- NL** Kabelgoot middelzwaar
- F** Chemins de câbles série M

- D** Kabelrinnen M
- N** Medium kraftig kabelrenne type M
- S** Kabelränna medium med bockad fläns

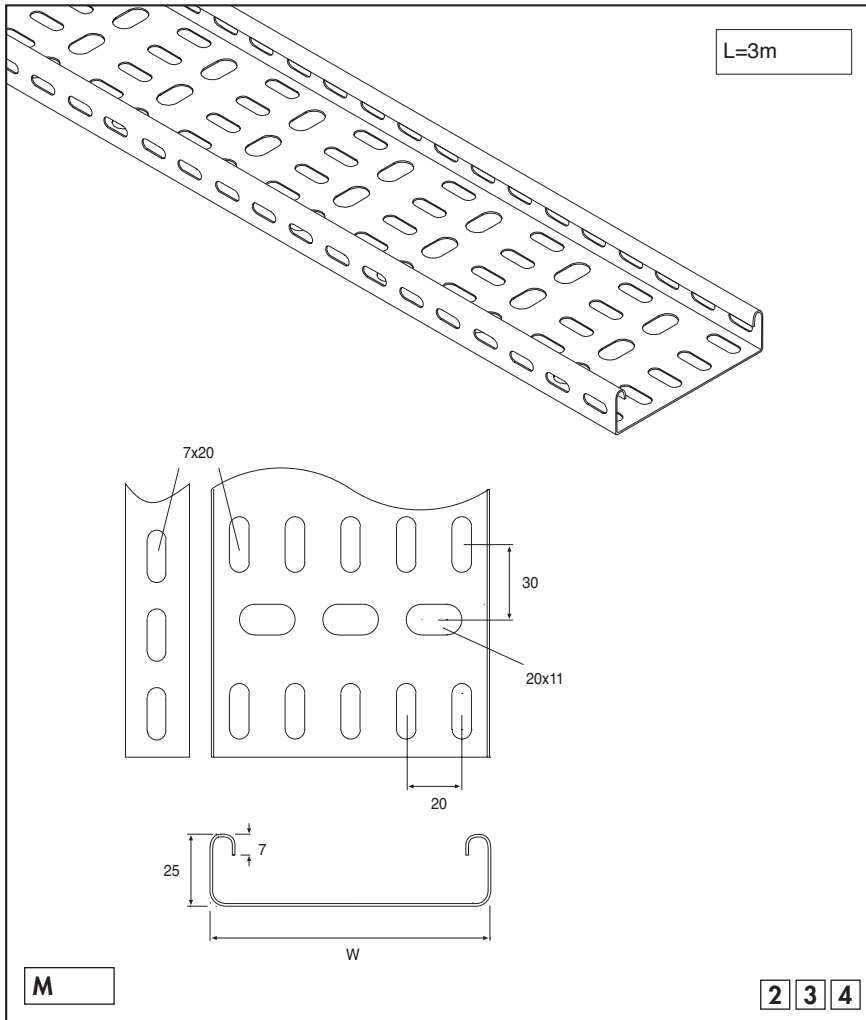

Art. Nr.	W mm	mm	kg
ML050/10 P	50	0,8	2,83
ML075/10 P	75	0,8	3,46
ML100/10 P	100	0,8	4,09
ML150/10 P	150	0,8	5,35
ML225/10 P	225	0,8	7,24
ML300/15 P	300	1,2	13,62
ML450/15 P	450	1,2	19,22
ML600/15 P	600	1,2	24,89
ML750/20 P	750	2,0	40,75
ML900/20 P	900	2,0	48,13

- GB** Tray couplers
- NL** Koppelplaten
- F** Eclisses

- D** Rinnenverbinder
- N** Skjøt
- S** Sidoskarv

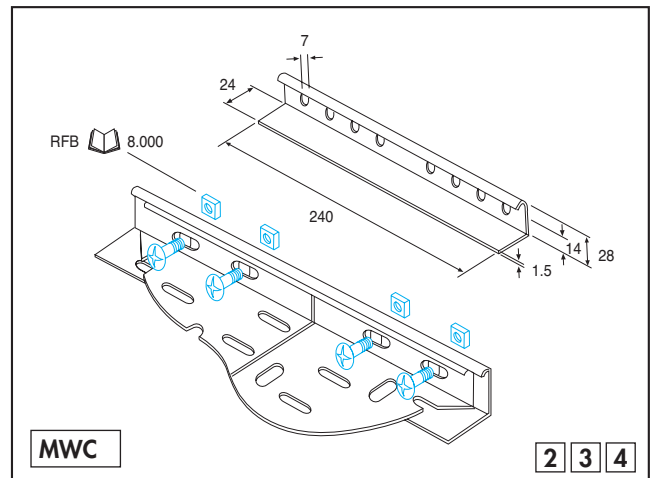
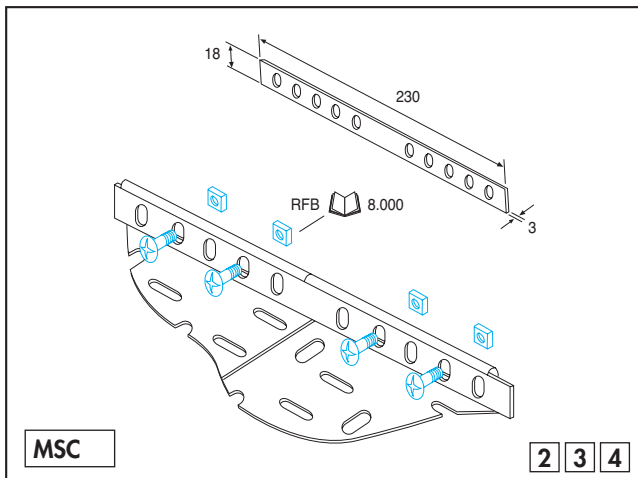

Art. Nr.	kg
MSC P	0,098

Art. Nr.	kg
MWC P	0,143

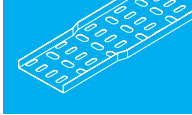

CABLE TRAY M-25 MM

Bogen 90°, T-Stück & Kreuzstück **D**

Bend, T-stykke og kryss **N**

Avgreningar **S**

Cabletray fittings **GB**

Bocht-, T-stuk en kruisstuk **NL**

Éléments de raccordement **F**

Art. Nr. 90°	Art. Nr. 45°	W mm	B		C mm	— — —		Ⓜ	
			90° mm	45° mm		mm	mm	90°	45°
MB050/90 P	MB050/45 P	50	172	112	74,5	0,8	0,43	0,28	
MB075/90 P	MB075/45 P	75	197	137	74,5	0,8	0,51	0,33	
MB100/90 P	MB100/45 P	100	222	162	74,5	0,8	0,64	0,42	
MB150/90 P	MB150/45 P	150	273	213	74,5	0,8	0,95	0,62	
MB225/90 P	MB225/45 P	225	347	287	74,5	0,8	1,53	0,99	
MB300/90 P	MB300/45 P	300	422	362	74,5	1,2	2,37	1,54	
MB450/90 P	MB450/45 P	450	572	512	74,5	1,2	4,67	3,04	
MB600/90 P	MB600/45 P	600	722	662	74,5	1,2	7,20	4,68	
MB750/90 P	MB750/45 P	750	872	812	74,5	2,0	10,15	6,60	
MB900/90 P	MB900/45 P	900	1022	962	74,5	2,0	13,46	8,75	

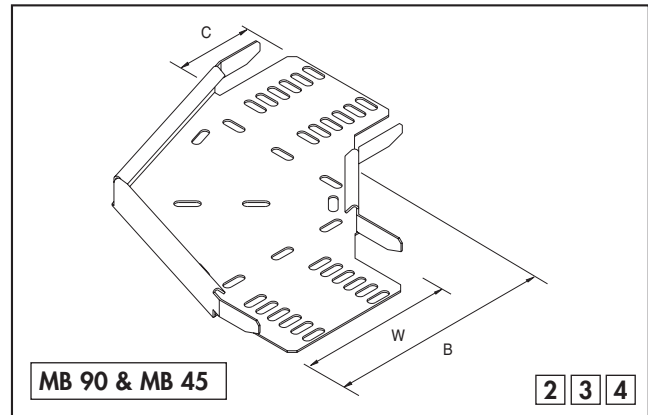

Art. Nr.	W mm	B mm	C mm	— — — mm	Ⓜ
MT050 P	50	172	74,5	0,8	0,69
MT075 P	75	197	74,5	0,8	0,86
MT100 P	100	222	74,5	0,8	1,06
MT150 P	150	273	74,5	0,8	1,49
MT225 P	225	347	74,5	0,8	2,27
MT300 P	300	422	74,5	1,2	3,44
MT450 P	450	572	74,5	1,2	6,81
MT600 P	600	722	74,5	1,2	10,53
MT750 P	750	872	74,5	2,0	12,20
MT900 P	900	1022	74,5	2,0	18,65

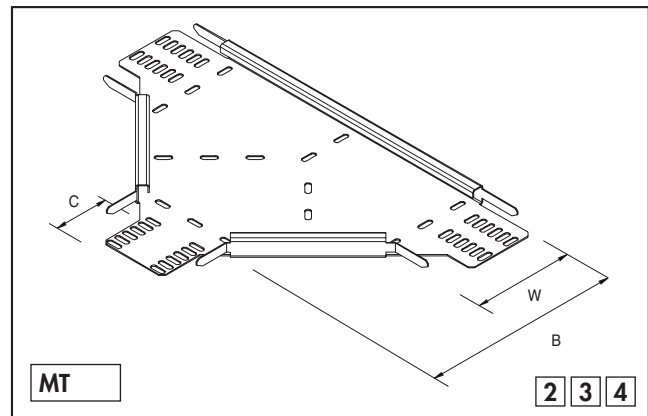

Art. Nr.	W mm	B mm	C mm	— — — mm	Ⓜ
MX050 P	50	172	74,5	0,8	1,00
MX075 P	75	197	74,5	0,8	1,17
MX100 P	100	222	74,5	0,8	1,40
MX150 P	150	273	74,5	0,8	1,89
MX225 P	225	347	74,5	0,8	2,77
MX300 P	300	422	74,5	1,2	3,81
MX450 P	450	572	74,5	1,2	8,13
MX600 P	600	722	74,5	1,2	12,32
MX750 P	750	872	74,5	2,0	13,38
MX900 P	900	1022	74,5	2,0	17,45

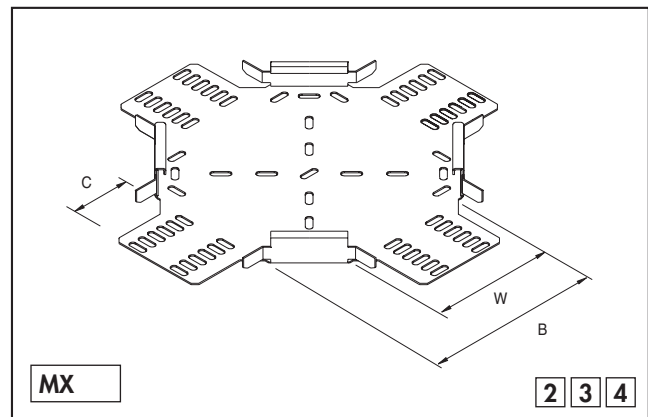

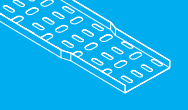

CABLE TRAY M-25 MM

- GB Flexible riser
- NL Flexibele stijg- en vervalstukken
- F Eléments de raccordement

- D Flexibler Vertikalbogen
- N Flexibel riser
- S Flexibel nivåled

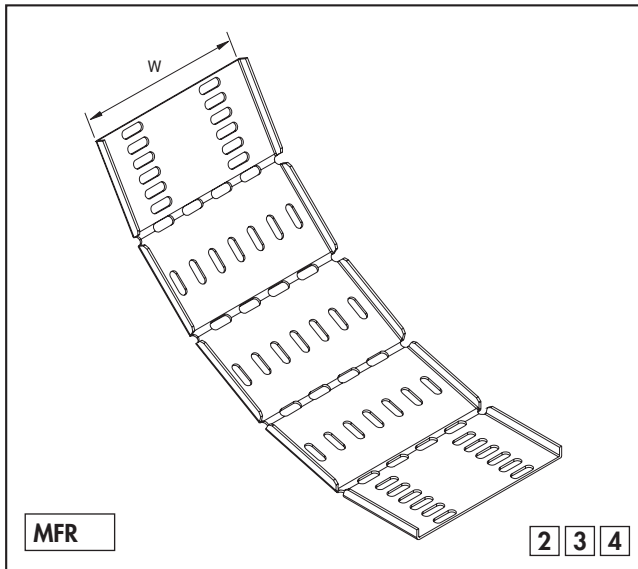

Art. Nr.	W mm	mm	kg
MFR050 P	50	0,8	0,176
MFR075 P	75	0,8	0,238
MFR100 P	100	0,8	0,304
MFR150 P	150	0,8	0,424
MFR225 P	225	0,8	0,619
MFR300 P	300	1,2	1,188
MFR450 P	450	1,2	1,752
MFR600 P	600	1,2	2,373
MFR750 P	750	2,0	3,190
MFR900 P	900	2,0	4,010

- GB Used as inside riser:
- NL Als stijgstuk:
- F Exemple de montage:
- D als Steigestück
- N Brukt som innvendig riser
- S Invändig

- GB Used as outside riser:
- NL Als vervalstuk:
- F Exemple de montage:
- D als Fallstück
- N Brukt som utvendig riser
- S Utvändig

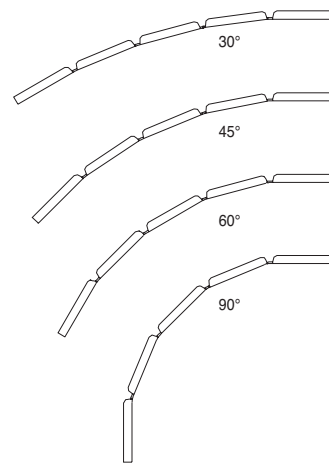
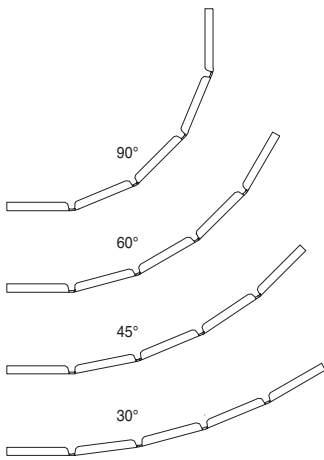



CABLE TRAY M-25 MM

Reduzierstücke **D**

Reduksjon **N**

Reducering **S**

Cabletray reducers **GB**

Verloopstukken **NL**

Reductions **F**

Art.nr.	W1 mm	W2 mm	C mm	mm	kg
MS075/050 P	75	50	75	0,8	0,40
MS100/075 P	100	75	75	0,8	0,47
MS100/050 P	100	50	150	0,8	0,43
MS150/100 P	150	100	75	0,8	0,58
MS150/075 P	150	75	150	0,8	0,54
MS150/050 P	150	50	150	0,8	0,50
MS225/150 P	225	150	75	0,8	0,79
MS225/100 P	225	100	150	0,8	0,70
MS225/075 P	225	75	150	0,8	0,67
MS300/225 P	300	225	75	1,2	1,03
MS300/150 P	300	150	150	1,2	0,91
MS300/100 P	300	100	150	1,2	0,84
MS450/300 P	450	300	75	1,2	1,40
MS450/225 P	450	225	150	1,2	1,30
MS450/150 P	450	150	150	1,2	1,18
MS450/100 P	450	100	300	1,2	1,11
MS600/450 P	600	450	75	1,2	1,88
MS600/300 P	600	300	150	1,2	1,66
MS600/225 P	600	225	150	1,2	1,56
MS600/150 P	600	150	225	1,2	1,45
MS750/600 P	750	600	75	2,0	3,00
MS750/450 P	750	450	150	2,0	2,71
MS750/300 P	750	300	150	2,0	2,45
MS750/225 P	750	225	300	2,0	2,32
MS900/750 P	900	750	75	2,0	3,61
MS900/600 P	900	600	150	2,0	3,32
MS900/450 P	900	450	150	2,0	3,06
MS900/300 P	900	300	300	2,0	2,80

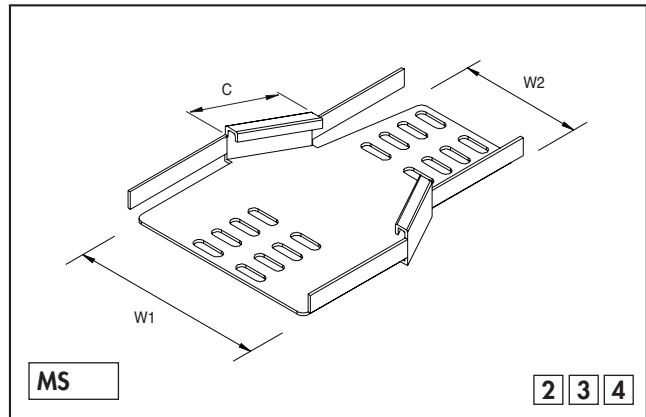

CABLE
TRAY

CABLE TRAY H-50 MM

- GB** Heavy duty return flange cabletray
- NL** Kabelgoot zwaar
- F** Chemins de câbles série H

- D** Kabelrinnen H
- N** Kraftig kabelrenne type H
- S** Kabelränna extra kraftig med bockad fläns

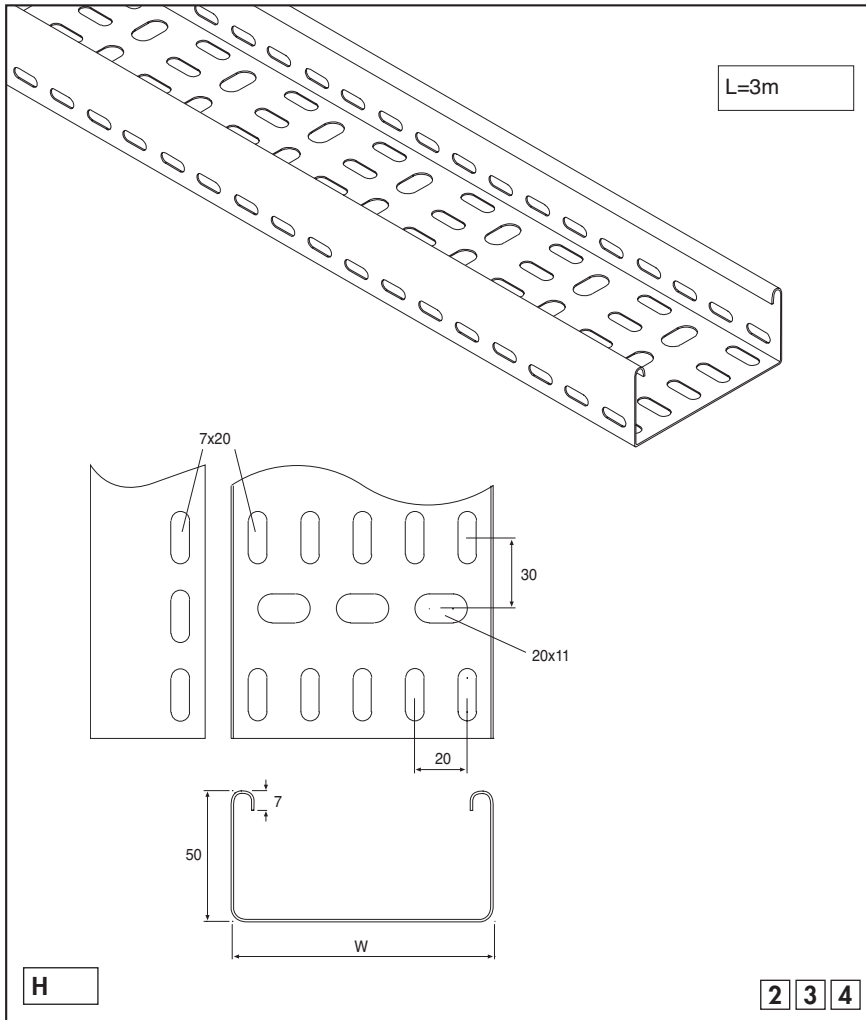

Art. Nr.	W mm	mm	kg
HL075/10 P	75	0,8	5,73
HL100/10 P	100	0,8	6,36
HL150/10 P	150	0,8	7,62
HL225/15 P	225	1,2	14,27
HL300/15 P	300	1,2	17,11
HL450/20 P	450	2,0	30,18
HL600/20 P	600	2,0	37,74
HL750/20 P	750	2,0	45,30
HL900/20 P	900	2,0	52,85

- GB** Tray couplers
- NL** Koppelplaten
- F** Eclisses

- D** Rinnenverbinder
- N** Skjøt
- S** Sidoskarv

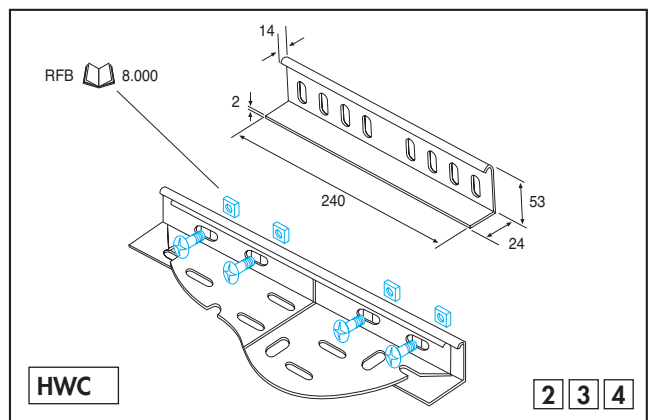
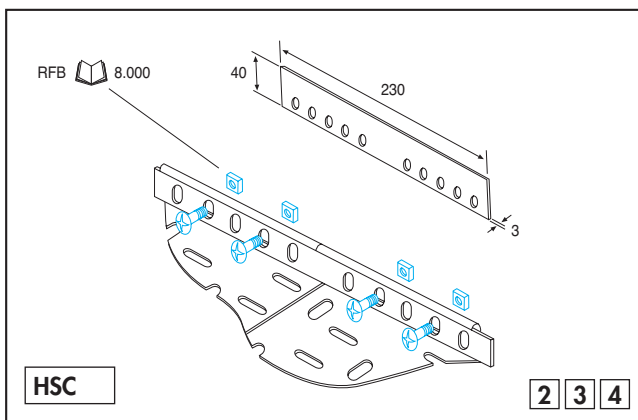

Art.nr.	kg
HSC P	0,34

Art.nr.	kg
HWC P	0,41



CABLE TRAY

Bogen 90°, T-Stück & Kreuzstück **D**

Bend, T-stykke og kryss **N**

Avgreningar **S**

Cabletray fittings **GB**

Bocht-, T-stuk en kruisstuk **NL**

Éléments de raccordement **F**

Art. Nr. 90°	Art. Nr. 45°	W mm	B		C mm	— — mm	⊥	
			90° mm	45° mm			90°	45°
HB075/90 P	HB075/45 P	75	197	139	74,5	0,8	0,80	0,52
HB100/90 P	HB100/45 P	100	222	164	74,5	0,8	0,97	0,63
HB150/90 P	HB150/45 P	150	272	214	74,5	0,8	1,30	0,85
HB225/90 P	HB225/45 P	225	347	342	74,5	1,2	1,96	1,27
HB300/90 P	HB300/45 P	300	422	432	74,5	1,2	2,89	1,88
HB450/90 P	HB450/45 P	450	572	620	74,5	1,2	5,39	3,50
HB600/90 P	HB600/45 P	600	722	770	74,5	1,2	8,06	5,24
HB750/90 P	HB750/45 P	750	872	920	74,5	2,0	11,10	7,22
HB900/90 P	HB900/45 P	900	1022	1070	74,5	2,0	14,69	9,55

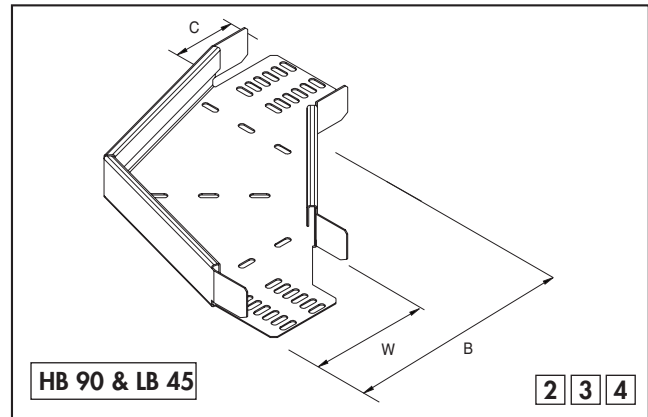

Art. Nr.	W mm	B mm	C mm	— — mm	⊥
HT075 P	75	197	74,5	0,8	1,23
HT100 P	100	222	74,5	0,8	1,46
HT150 P	150	272	74,5	0,8	1,89
HT225 P	225	347	74,5	1,2	2,73
HT300 P	300	422	74,5	1,2	3,97
HT450 P	450	572	74,5	1,2	7,61
HT600 P	600	722	74,5	1,2	11,31
HT750 P	750	872	74,5	2,0	12,84
HT900 P	900	1022	74,5	2,0	19,46

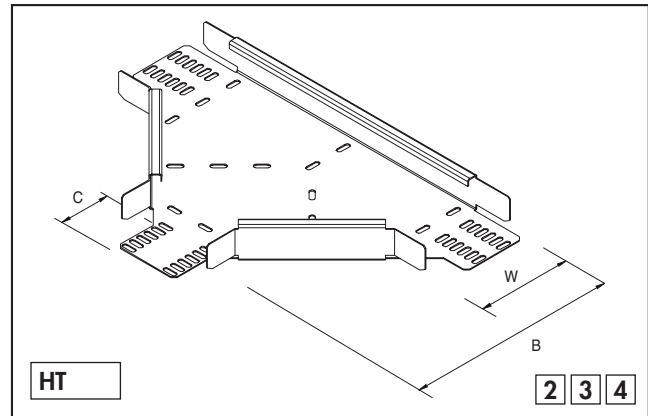

Art. Nr.	W mm	B mm	C mm	— — mm	⊥
HX075 P	75	197	74,5	0,8	1,58
HX100 P	100	222	74,5	0,8	1,80
HX150 P	150	272	74,5	0,8	2,28
HX225 P	225	347	74,5	1,2	3,15
HX300 P	300	422	74,5	1,2	4,16
HX450 P	450	572	74,5	1,2	8,61
HX600 P	600	722	74,5	1,2	12,78
HX750 P	750	872	74,5	2,0	13,65
HX900 P	900	1022	74,5	2,0	17,64

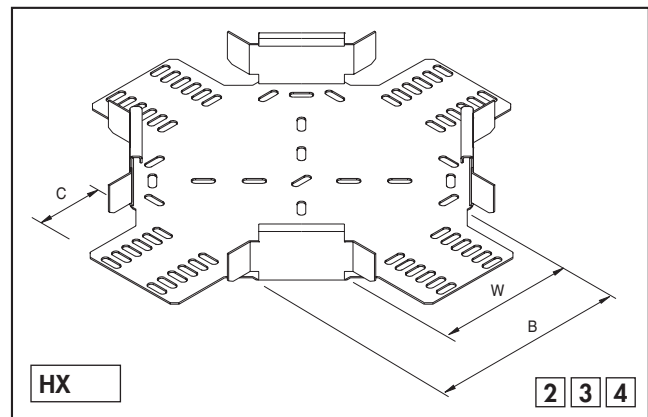

CABLE TRAY H-50 MM

- GB** Flexible riser
- NL** Flexibele stijg- en vervalstukken
- F** Éléments de raccordement

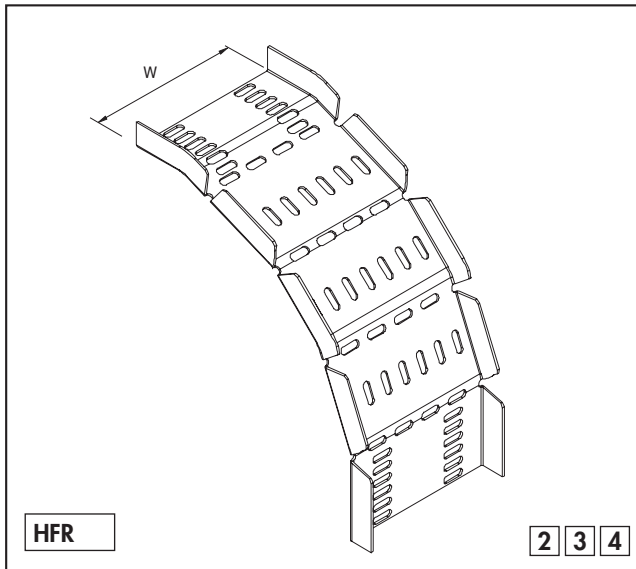

- D** Flexibler Vertikalbogen
- N** Flexibel riser
- S** Flexibel nivåled

Art. Nr.	W mm	± mm	Ⓜ
HFR075 P	75	0,8	0,33
HFR100 P	100	0,8	0,40
HFR150 P	150	0,8	0,52
HFR225 P	225	1,2	1,07
HFR300 P	300	1,2	1,33
HFR450 P	450	1,2	1,90
HFR600 P	600	1,2	2,52
HFR750 P	750	2,0	3,34
HFR900 P	900	2,0	4,16

- GB** Used as inside riser:
- D** als Steigestück
- NL** Als stijgstuk:
- N** Brukt som innvendig riser
- F** Exemple de montage:
- S** Utvändig

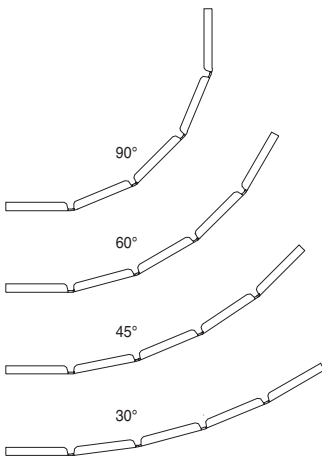

- GB** Used as outside riser:
- D** als Fallstück
- NL** Als vervalstuk:
- N** Brukt som utvendig riser
- F** Exemple de montage:
- S** Invändig

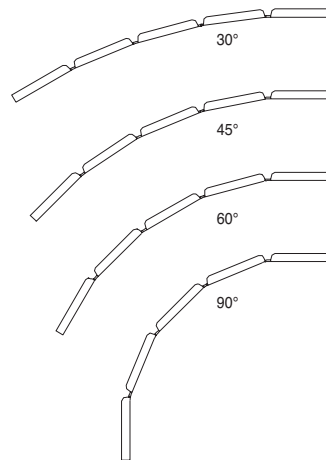



CABLE TRAY H-50 MM

Reduzierstücke **D**

Reduksjon **N**

Reducering **S**

Cabletray reducers **GB**

Verloopstukken **NL**

Reductions **F**

Art. Nr.	W1 mm	W2 mm	C mm	→ ← mm	⌀ mm
HS100/075 P	100	75	254	0,8	0,75
HS150/100 P	150	100	254	0,8	0,87
HS150/075 P	150	75	254	0,8	0,83
HS225/150 P	225	150	254	0,8	1,07
HS225/100 P	225	100	254	0,8	1,00
HS225/075 P	225	75	254	0,8	0,97
HS300/225 P	300	225	254	0,8	1,32
HS300/150 P	300	150	254	0,8	1,21
HS300/100 P	300	100	254	0,8	1,14
HS450/300 P	450	300	254	1,2	1,88
HS450/225 P	450	225	254	1,2	1,60
HS450/150 P	450	150	254	1,2	1,51
HS450/100 P	450	100	254	1,2	1,45
HS600/450 P	600	450	254	1,2	2,21
HS600/300 P	600	300	254	1,2	1,94
HS600/225 P	600	225	254	1,2	1,91
HS600/150 P	600	150	254	1,2	1,89
HS750/600 P	750	600	300	2,0	3,37
HS750/450 P	750	450	300	2,0	3,09
HS750/300 P	750	300	300	2,0	2,84
HS750/225 P	750	225	300	2,0	2,71
HS900/750 P	900	750	300	2,0	4,00
HS900/600 P	900	600	300	2,0	3,74
HS900/450 P	900	450	300	2,0	3,53
HS900/300 P	900	300	300	2,0	3,32

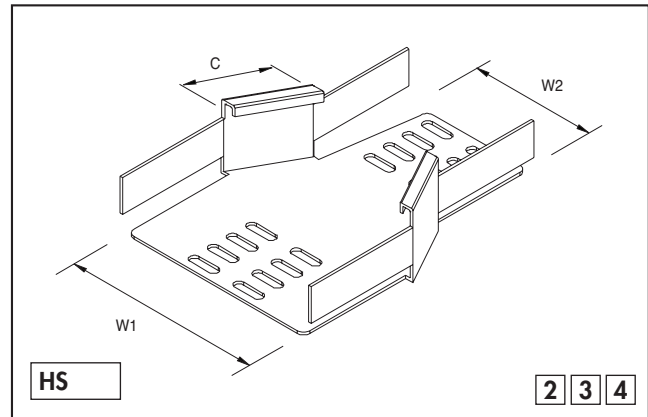

CABLE
TRAY

CABLE TRAY

- GB** Covers
- NL** Dekfels
- F** Couvertcles

- D** Deckel
- N** Dekkplate
- S** Täckplåt

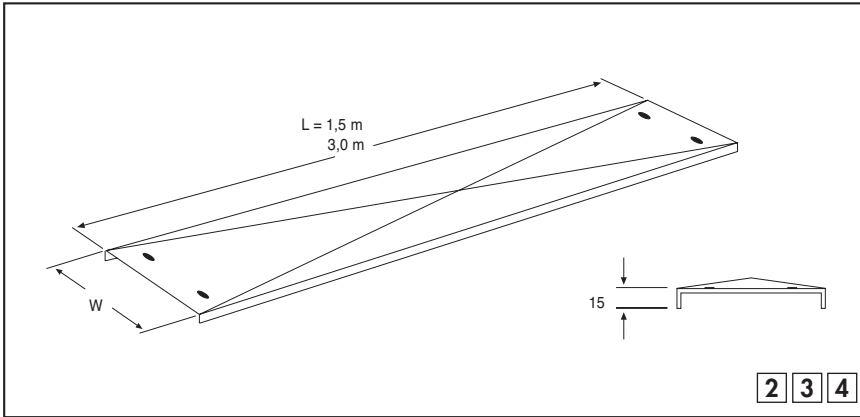

Art. Nr.	W mm
TUHL075 P	75
TUHL100 P	100
TUHL150 P	150
TUHL225 P	225
TUHL300 P	300
TUHL450 P	450
TUHL600 P	600
TUHL750 P	750
TUHL900 P	900

On request
Op aanvraag
Sur demande
Auf Anfrage
På forespørsel
På förfrågan

- L = 1,5 m : 4 Cover fixings 4 Deckelbefestigungsklammern
4 Deksel bevestigingen 4 Fester
4 Fixations des couvercles 4 Täckplåts skruv
- L = 3,0 m : 6 Cover fixings 6 Deckelbefestigungsklammern
6 Deksel bevestigingen 6 Fester
6 Fixations des couvercles 6 Täckplåts skruv

- GB** Cover fixings
- NL** Deksel bevestigingen
- F** Fixations des couvercles

- D** Deckelbefestigungsklammern
- N** Fester for dekkplate
- S** Skruv till täckplåt

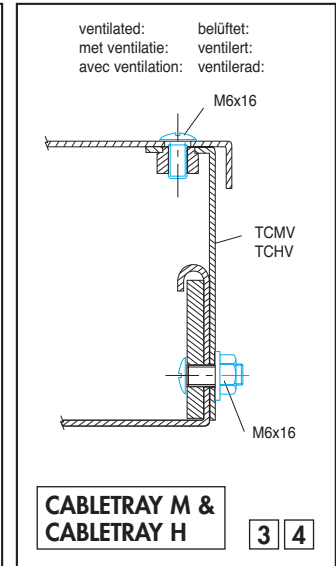
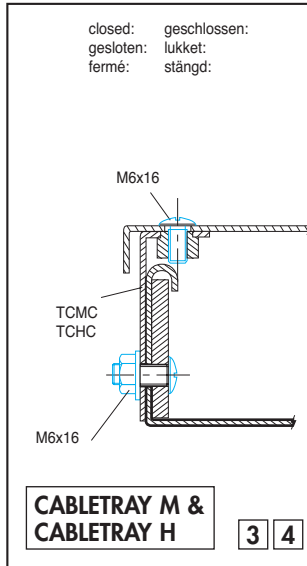
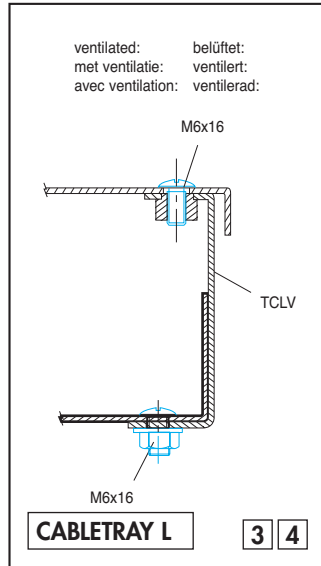
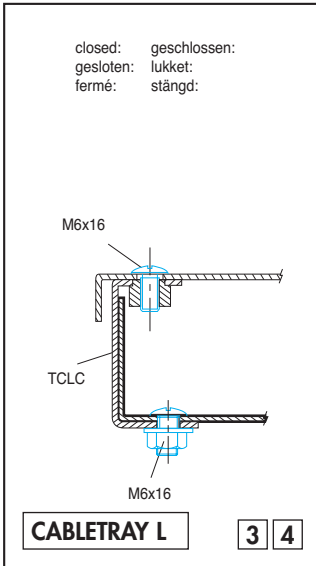

Art. Nr.
TCLC P

Art. Nr.
TCLV P

Art. Nr.	Type
TCMC P	M
TCHC P	H

Art. Nr.	Type
TCMV P	M
TCHV P	H

- GB** Earth continuity connector
- NL** Aardingsstrip
- F** Conducteur de protection

- D** Erdungsband
- N** Jording
- S** Jordning

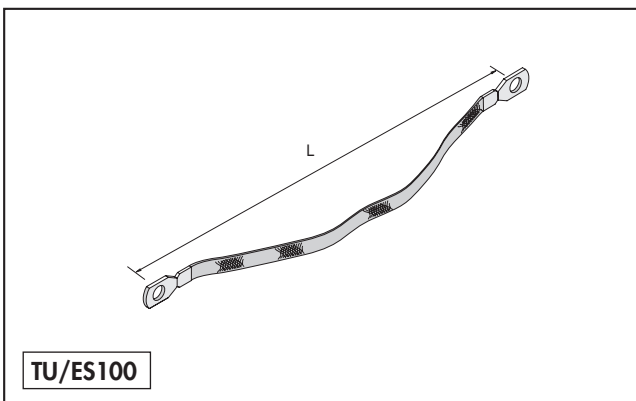

Art. Nr.	L mm	⚖️	📦
TU/ES100	100	0,02	10



CABLE TRAY

Konsolen **D**

Konsoller **N**

Konsol **S**

Traying arms **GB**

Konsoles **NL**

Consoles **F**

Art. Nr.	W mm	H mm	Fmax N		
P2491/100 P	105	63	1,6	0,2	1
P2491/150 P	155	63	1,6	0,28	1
P2491/225 P	230	75	1,5	0,4	1
P2491/300 P	305	87	1,4	0,58	1
P2491/450 P	455	125	1,1	1,0	1
P2491/600 P	605	164	1	1,575	1

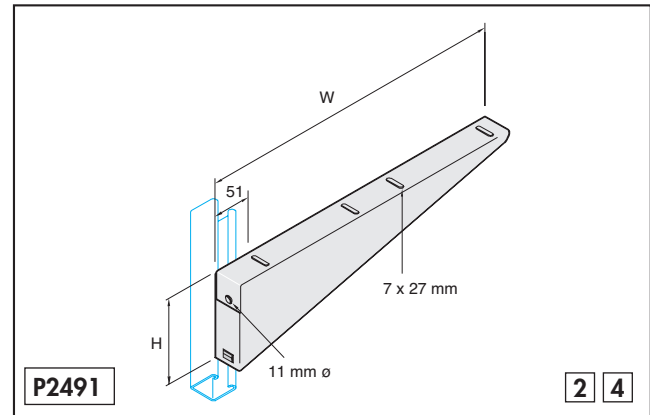

CABLE
TRAY

Abstandsbügel **D**

Festebakett **N**

Bärok **S**

Tray stand of bracket **GB**

Montage beugel **NL**

Fixation pour chemin **F**

Art. Nr.	W mm	WT mm	T mm		
TUSB050HG	50	154	2	0,11	1
TUSB075HG	75	179	2	0,16	1
TUSB100HG	100	204	2	0,18	1
TUSB150HG	150	254	2	0,21	1
TUSB225HG	225	329	4	0,51	1
TUSB300HG	300	404	4	0,60	1
TUSB450HG	450	554	4	0,79	1
TUSB600HG	600	704	4	0,97	1

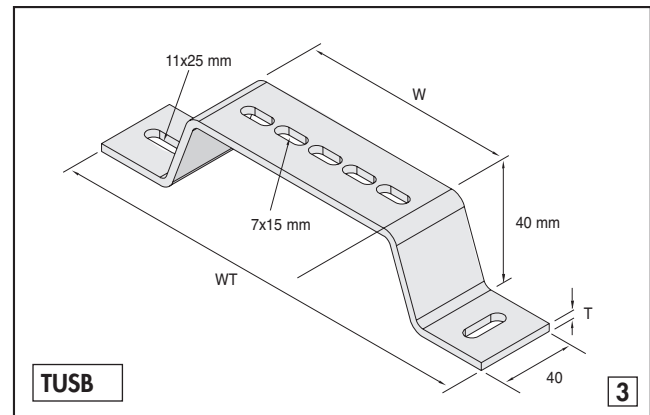

Aufhängebügel **D**

Åpen festebakett **N**

Konsol C - typ **S**

C-type hanging bracket **GB**

Open ophangbeugel **NL**

Etrier ouvert **F**

CABLE TRAY

GB Load data

NL Belastinggegevens

F Charges admissibles

D Belastungswerte

N Lastdata

S Belastningsdata

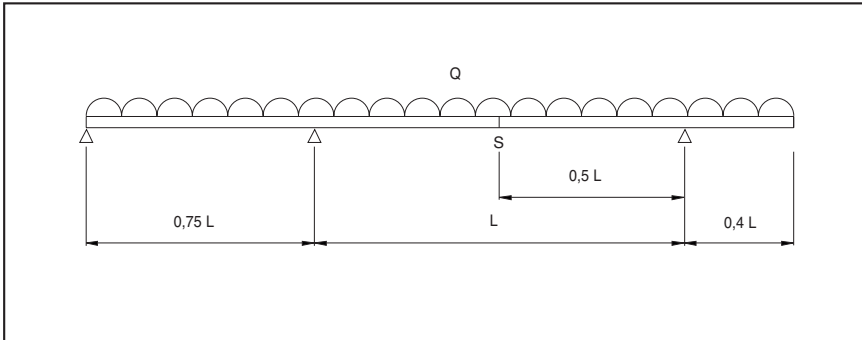

GB Load test according CEI/IEC 61537:2001

Q = UDL (uniformly distributed load)

Safety Factor = 1,7

L = intermediate span

F = deflection = 1/100 of the intermediate span (max.)

S = splice location

NL Belastingtest volgens CEI/IEC 61537:2001

Q = gelijkmatig verdeelde belasting

Veiligheidsfactor = 1,7

L = overspanning

F = doorbuiging = 1/100 van de overspanning (maximaal)

S = locatie van de koppelplaten

F Essai de charge suivant CEI/IEC 61537:2001

Q = CUR (charge uniformement repartie)

Coefficient de sécurité = 1,7

L = portée

F = flèche = 1/100 de la portée (max.)

S = position des éclisses

D Belastungsprüfung gemäß CEI/IEC 61537:2001

Q = Gleichlast

Sicherheitsbeiwert = 1,7

L = Stützabstand

F = Durchbiegung = 1/100 der Überspannung

S = Verbindungsstelle

N Belastningstest i henhold til CEI/IEC 61537:2001

Q = Jevnt fordelt last

Sikkerhetsfaktor = 1,7

L = Midtspenn

F = Nedbøyning = max 1/100 av L

S = Plassering av skjøt

S Belastnings test CEI/IEC 61537:2001

Q = UDL (uniformly distributed load, likformigt fördelad belastning)

L = Avstånd mellan fästpunkterna

F = Nedböjning = 1/100 av avståndet mellan fästpunkterna

S = Skarv punkt



CABLE TRAY

Belastungswerte **D**

Lastdata **N**

Belastingsdata **S**

Load data **GB**

Belastingsgegevens **NL**

Charges admissibles **F**

Width/ Breedte/ Largeur Breite Bredde Breidd (mm)	Useful cross section / Maximale capaciteit Capacité théorique maximale / Nutzquerschnitt / Nyttbart tværsnitt / Maximal belastning (cm ²)
50	5,4
75	8,1
100	10,9
150	16,6
225	24,9
300	49,9
450	75,1
600	95,3
750	119,3
900	143,3

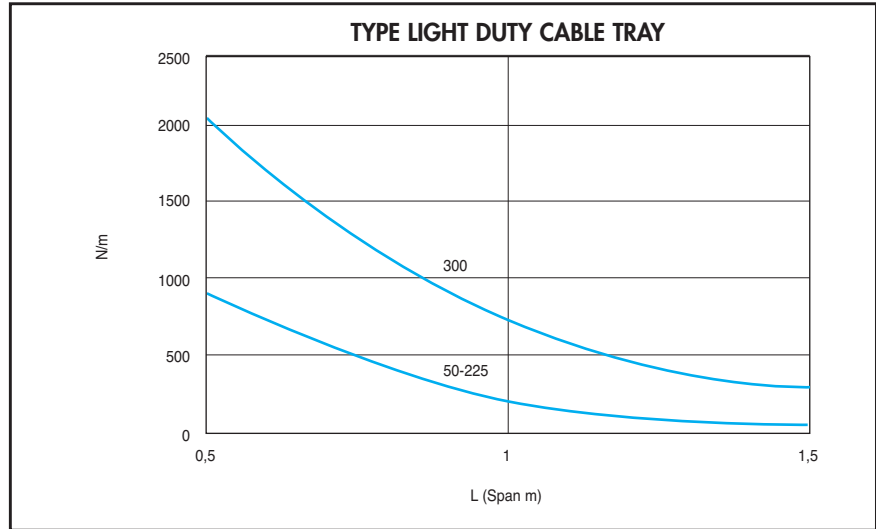

Width/ Breedte/ Largeur Breite Bredde Breidd (mm)	Useful cross section / Maximale capaciteit Capacité théorique maximale / Nutzquerschnitt / Nyttbart tværsnitt / Maximal belastning (cm ²)
50	11,4
75	17,4
100	23,5
150	35,6
225	53,7
300	70,4
450	106,1
600	141,8
750	171,1
900	205,6

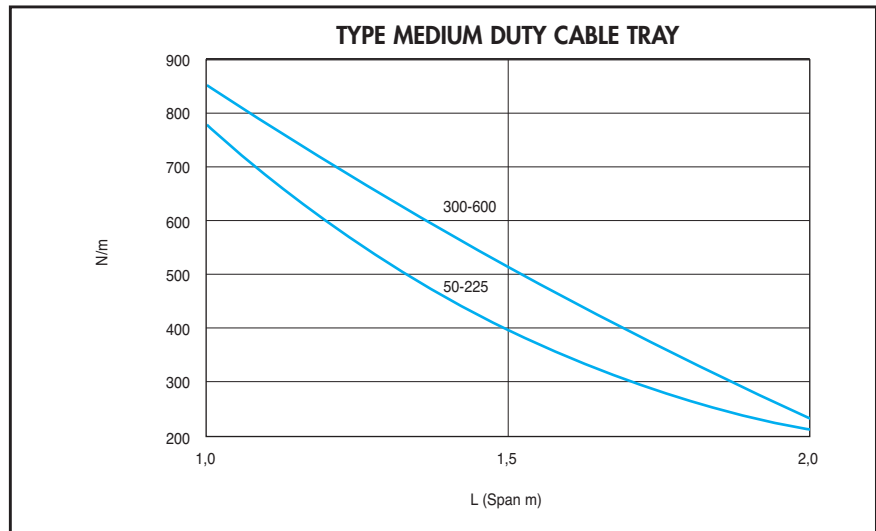

Width/ Breedte/ Largeur Breite Bredde Breidd (mm)	Useful cross section / Maximale capaciteit Capacité théorique maximale / Nutzquerschnitt / Nyttbart tværsnitt / Maximal belastning (cm ²)
50	35,8
100	48,1
150	72,7
225	108,2
300	144,8
450	213,6
600	285,6
750	357,6
900	429,6

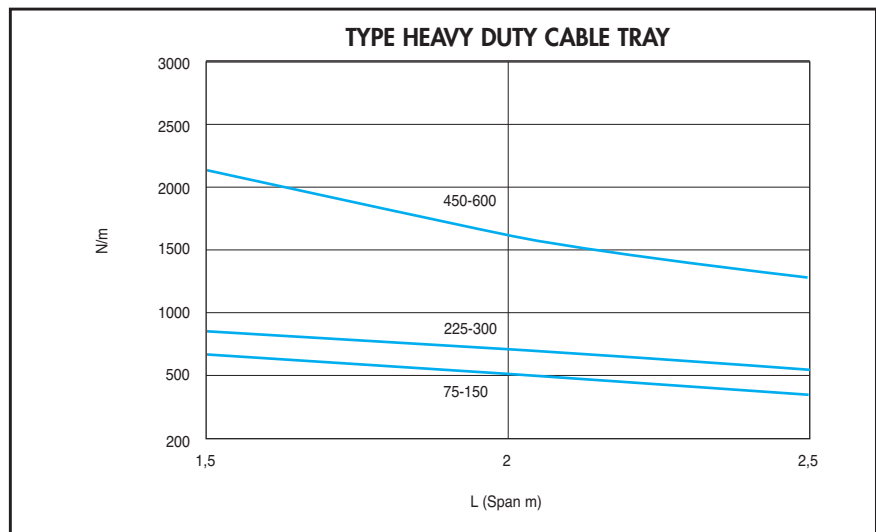

CABLE TRAY

TYCEUELSUP 0311

BASKET TRAY

GB Index
NL Inhoud
F Index

D Index
N Innhold
S Inehåll

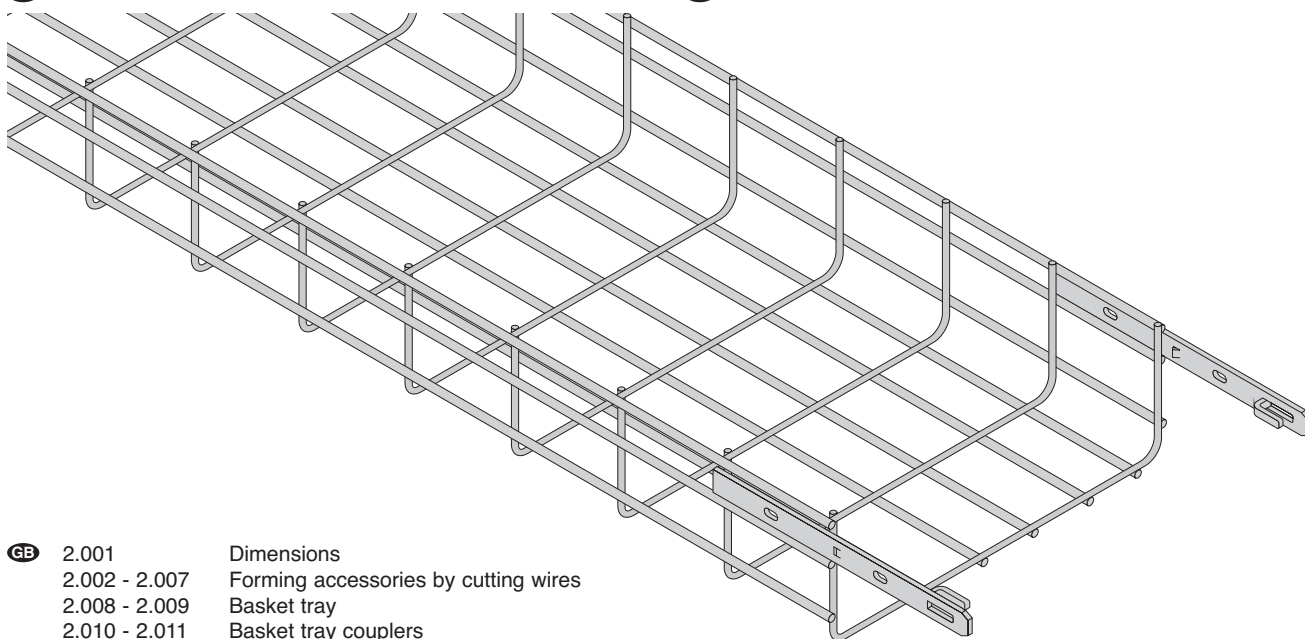

- | | |
|---|--|
| <p> GB 2.001 Dimensions
 2.002 - 2.007 Forming accessories by cutting wires
 2.008 - 2.009 Basket tray
 2.010 - 2.011 Basket tray couplers
 2.012 - 2.021 Supports & accessories
 2.022 - 2.023 Cable tray load data </p> | |
| <p> NL 2.001 Afmetingen
 2.002 - 2.007 Maken van hulpstukken door het knippen van draden
 2.008 - 2.009 Draadgoot
 2.010 - 2.011 Koppelplaten voor draadgoot
 2.012 - 2.021 Ondersteuning en accessoires
 2.022 - 2.023 Belastinggegevens van draadgoot </p> | |
| <p> F 2.001 Dimensions d'accessoires
 2.002 - 2.007 Creation d'accessoires par coupe des fils
 2.008 - 2.009 Chemins en fil
 2.010 - 2.011 Eclisses pour chemin en fil
 2.012 - 2.021 Supports et accessoires
 2.022 - 2.023 Courbes de charge </p> | |
| <p> D 2.001 Abmessungen
 2.002 - 2.007 Herstellen von Zubehör durch Schneiden der Drähte
 2.008 - 2.009 Gitterrinnen
 2.010 - 2.011 Gitterrinnenverbinder
 2.012 - 2.021 Befestigung und Zubehör
 2.022 - 2.023 Belastungswerte von Gitterrinnen </p> | |
| <p> N 2.001 Dimensjoner
 2.002 - 2.007 Produksjon av tilbehør ved å kutte tråder
 2.008 - 2.009 Kabelkurv
 2.010 - 2.011 Skjøter for kabelkurv
 2.012 - 2.021 Oppheng og tilbehør
 2.022 - 2.023 Belastningsdata </p> | |
| <p> S 2.001 Dimensioner
 2.002 - 2.007 Exempel på formning av nätrännor genom klippning av stålstänger.
 2.008 - 2.009 Nätrännor
 2.010 - 2.011 Fästen
 2.012 - 2.021 Upphängningar & tillbehör
 2.022 - 2.023 Belastnings data för nätrännor </p> | |

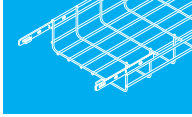

BASKET TRAY

Abmessungen **D**
 Dimensjoner **N**
 Dimensioner **S**

Dimensions **GB**
 Afmetingen **NL**
 Dimensions **F**

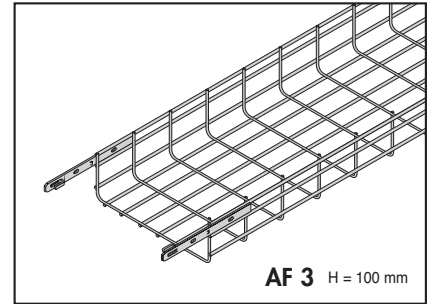
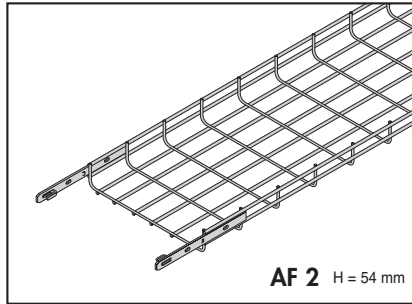
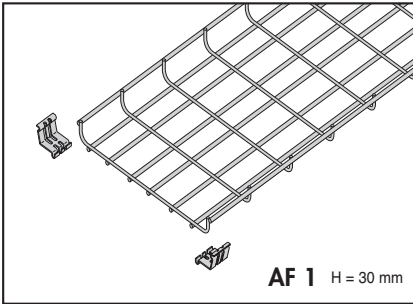

Type	H	W (mm)							
		50	100	150	200	300	400	500	600
AF1	30 mm	√	√	√	√	√	-	-	-
AF2	54 mm	√	√	√	√	√	√	√	√
AF3	100 mm	-	√	-	√	√	√	√	-
T 5 3 (mm)		Ø 4,5		Ø 5		Ø 6			
T 4 (mm)		Ø 5							

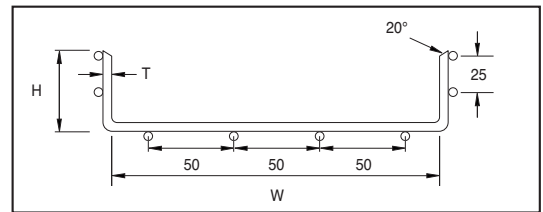

BASKET TRAY

Mit standard Verbindern **D**
 Med løse skjøter **N**
 Med standard skarvbeslag **S**

With normal couplers **GB**
 Met standaard koppelstukken **NL**
 Avec eclisses standards **F**

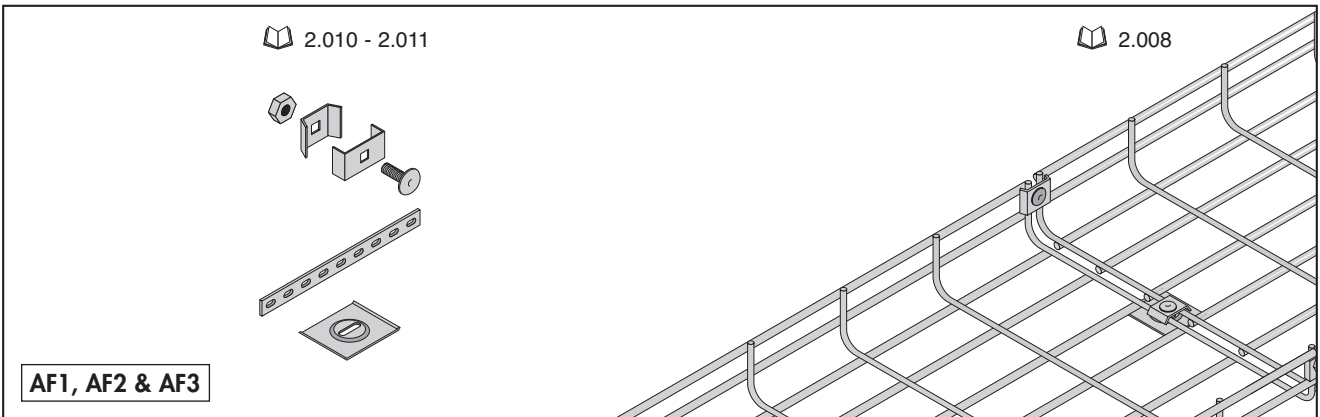

Mit angeschweißten Verbindern **D**
 Med påsveiste skjøter **N**
 Med svetsade snabbkopplingar **S**

Self-splicing type **GB**
 Met gelaste koppelplaten **NL**
 Version auto-eclissable **F**

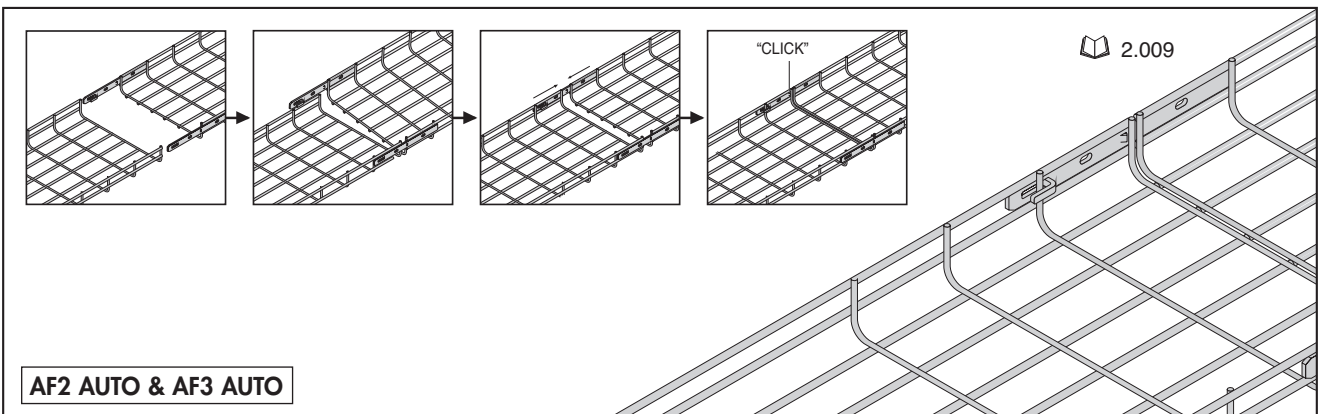

TYCEUELSUP 0311

BASKET TRAY

- GB** Make accessories by cutting wires
- DE** Herstellen von Zubehör durch Schneiden der Drähte
- NL** Maak hulpstukken door knippen van de goot
- NO** Produksjon av tilbehør ved å kutte tråder
- F** Réalisation d'accessoires sur chantier
- S** Tillverkning och formnig av nätrännor genom klippning av stålstänger

2.011

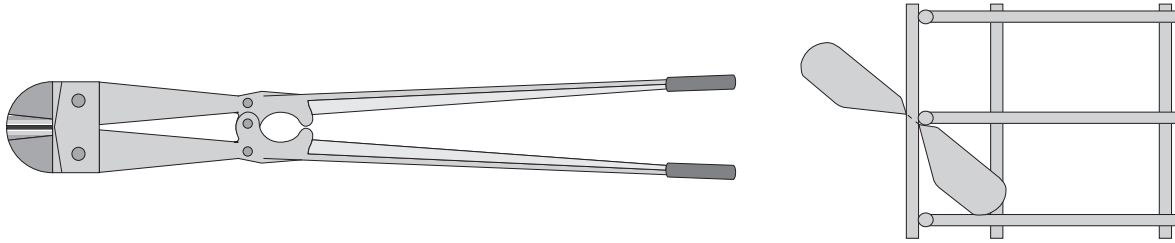

2.003

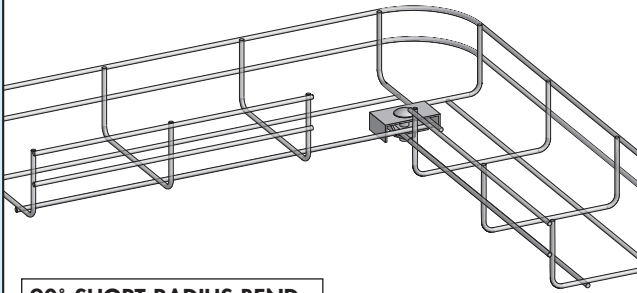

90° SHORT RADIUS BEND

2.004 - 2.005

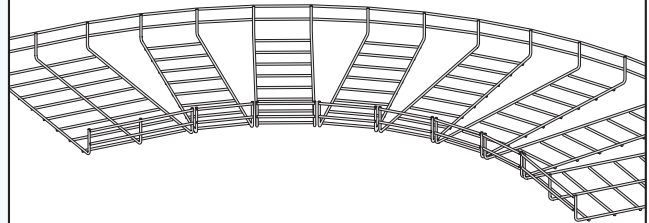

90° LONG RADIUS BEND

2.006

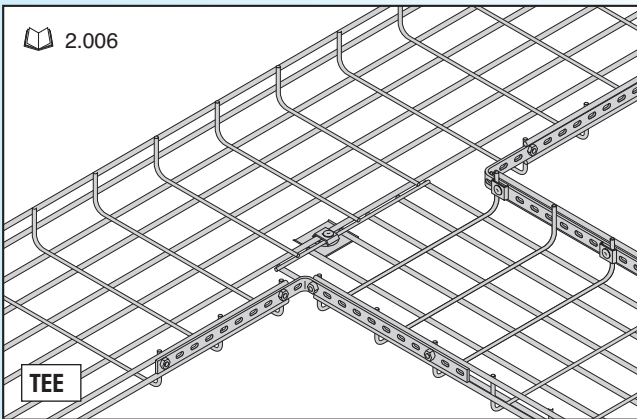

TEE

2.007

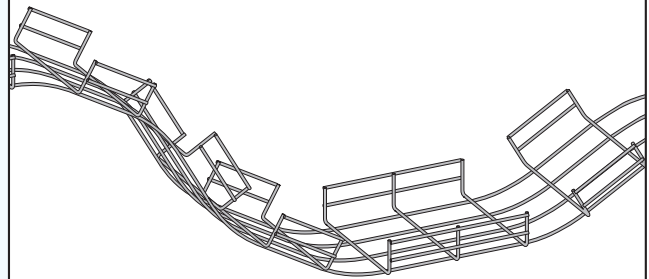

RISERS

BASKET TRAY

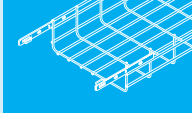

BASKET TRAY

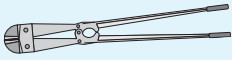

- CB Cut out D Ausschneiden
- NB Wegknippen N Klipp vekk
- F Coupe S Klipp ut

- 90° Bogen kurz D
- 90° bend – liten radius N
- Bøj kort radié S

- 90° Bends - short radius CB
- 90° Korte bocht NL
- Coude à 90° F

W100 - 300 mm
(1x) A2
(1x) A3
(1x) NBPM6

W400 - 600 mm
(2x) A2
(2x) A3
(2x) NBPM6

2.010 - 2.011

2.010 - 2.011

W (mm)	R (mm)	B (mm)
100	150	375
150	125	425
200	125	425
300	125	525
400	125	625
500	125	725

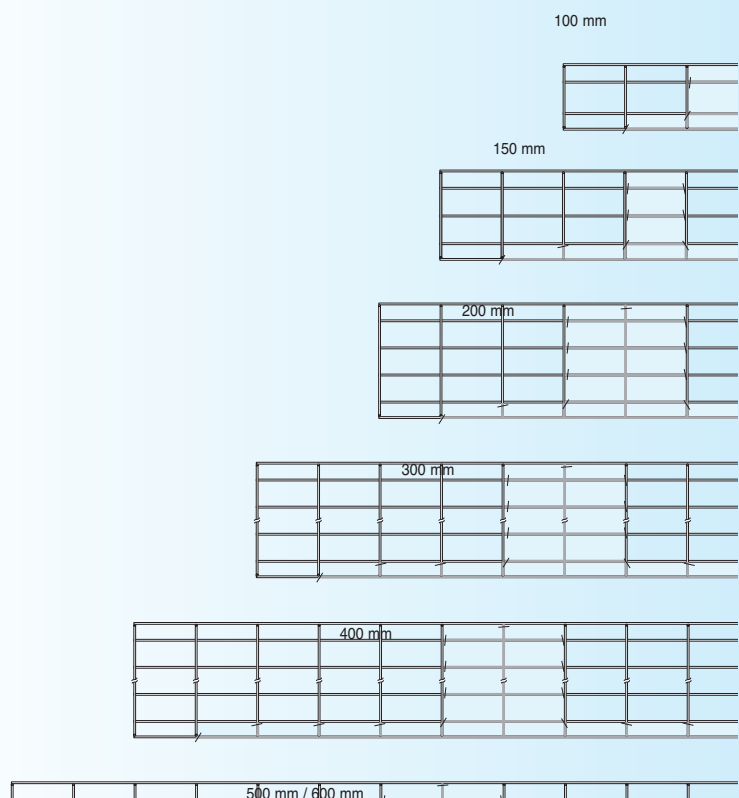
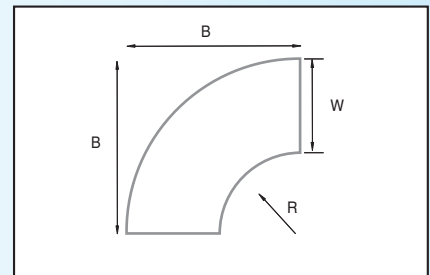

BASKET TRAY

TYCEUELSUP 0311

BASKET TRAY

- GB** 90° Bends, large radius, 100-200 mm wide
- NL** 90° Bochten, grote radius, 100-200 mm breed
- F** Coudes à 90°, grand rayon, largeurs 100-200 mm
- D** 90° Bogen, großer Radius, 100-200mm breit
- N** 90° bend - stor radius 100 - 200 mm bredde
- S** Böj, stor radie, 100 - 200 mm bred

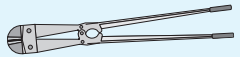

- GB** Cut out
- NL** Wegknippen
- F** Coupe
- D** Ausschneiden
- N** Klipp vekk
- S** Klipp ut

BASKET TRAY

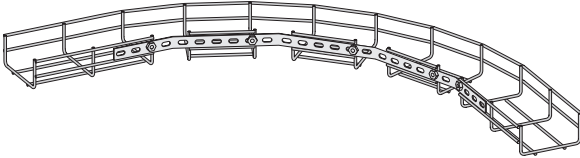

2.010 - 2.011 R = 400 mm

(1x) A5
(5x) A3
(5x) NBPM6

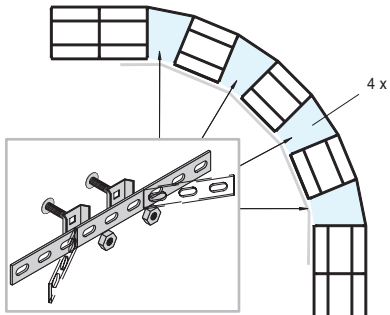

AF2 & AF3 W=100 mm

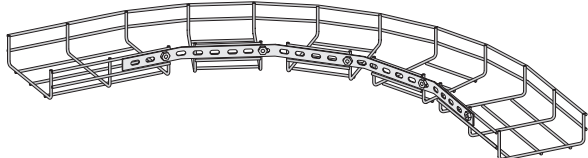

2.010 - 2.011 R = 300 mm

(1x) A5
(5x) A3
(5x) NBPM6

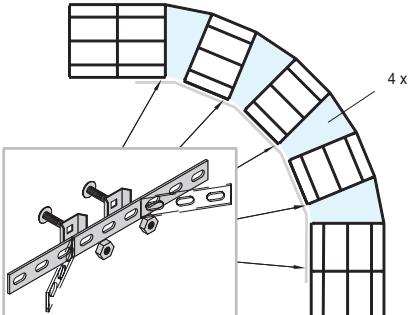

AF2 & AF3 W=150 mm

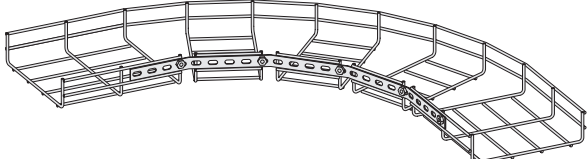

2.010 - 2.011 R = 300 mm

(1x) A5
(5x) A3
(5x) NBPM6

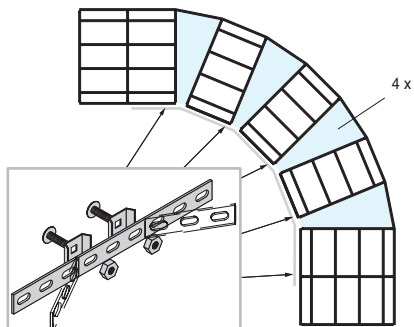

AF2 & AF3 W=200 mm

TYCEUELSUP 0311

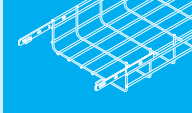

BASKET TRAY

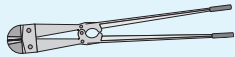

- GB Cut out
- DE Ausschneiden
- NL Wegknippen
- FI Klipp vekki
- F Coupe
- S Klipp ut

90° Bogen, großer Radius, 300-600mm breit **D**

90° Bends, large radius, 300-600 mm wide **GB**

90° bend - stor radius 300 - 600 mm bredde **N**

90° Bochten, grote radius, 300-600 mm breed **NL**

böj, lång radie, 300 - 600 mm bred **S**

Coudes à 90°, grand rayon, largeurs 300-600 mm **F**

2.010 - 2.011

R = 425 mm

- (1x) A5
- (7x) A3
- (7x) NBPM6

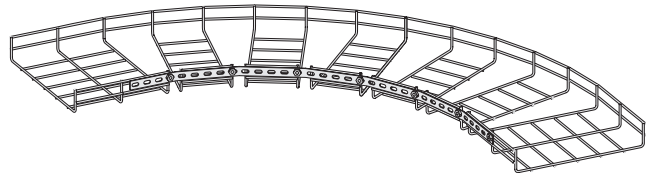
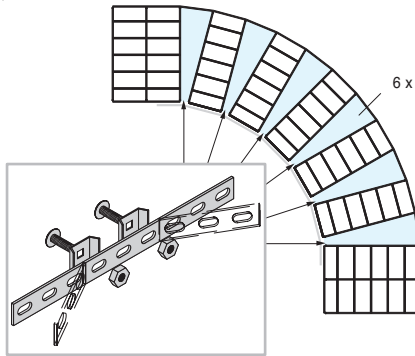

AF2 & AF3 W = 300 mm

2.010 - 2.011

R = 450 mm

- (1x) A5
- (8x) A3
- (8x) NBPM6

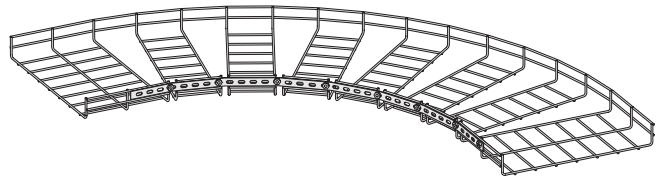
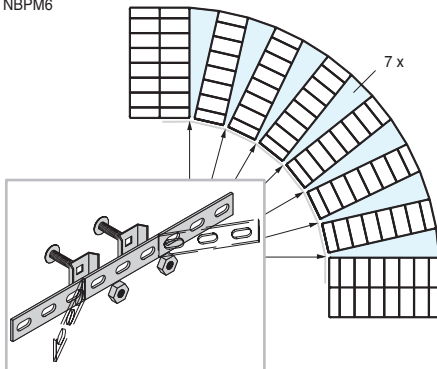

AF2 & AF3 W = 400 mm

2.010 - 2.011

R = 600 mm

- (1x) A5
- (10x) A3
- (10x) NBPM6

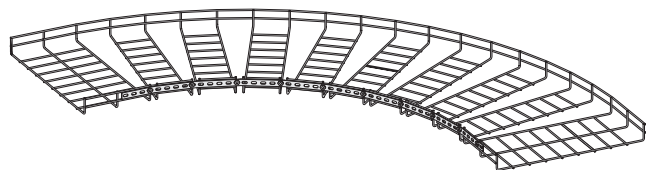
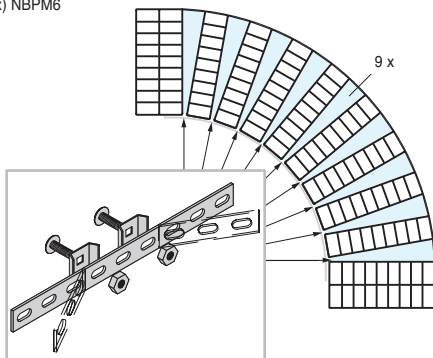

AF2 W = 600 mm

AF2 & AF3 W = 500 mm

BASKET TRAY

- GB** Standard tee
- NL** T-stuk
- F** Tê

- D** T-Stück
- N** Standard T-stykke
- S** Standard T

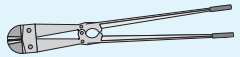

- GB** Cut out
- D** Ausschneiden
- NL** Wegknippen
- N** Klipp vekk
- F** Coupe
- S** Klipp ut

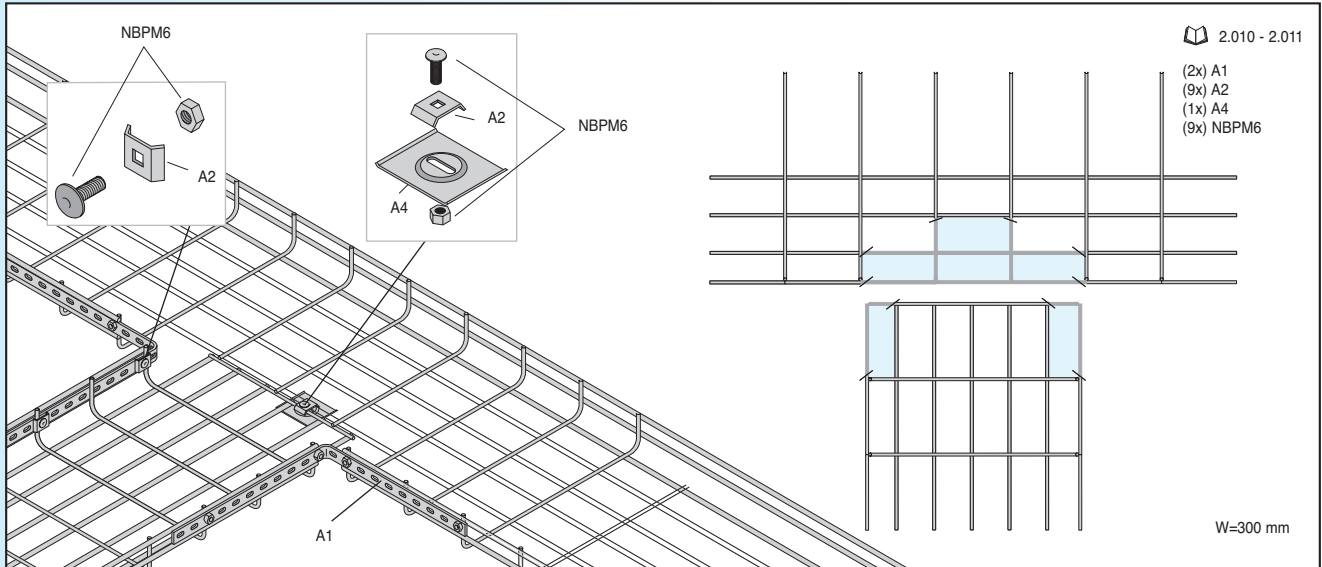

- GB** Cross
- NL** Kruisstuk
- F** Croix

- D** Kreuz
- N** Kryss
- S** Kors

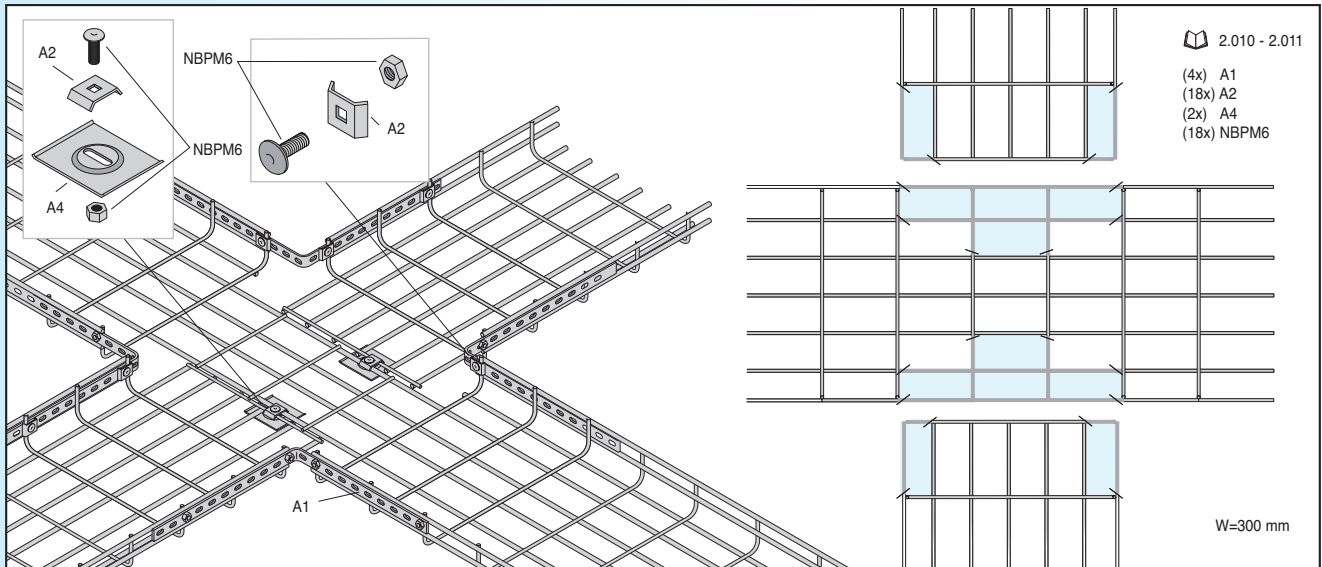

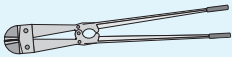
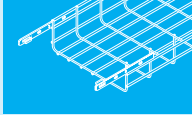

- GB** Cut out **D** Ausschneiden
- NL** Wegknippen **N** Klipp vekk
- F** Coupe **S** Klipp ut

BASKET TRAY

- Reduzierstücke** **D**
- Reduksjon** **N**
- Förminskning** **S**

- Reducer** **GB**
- Verloopstukken** **NL**
- Réduction** **F**

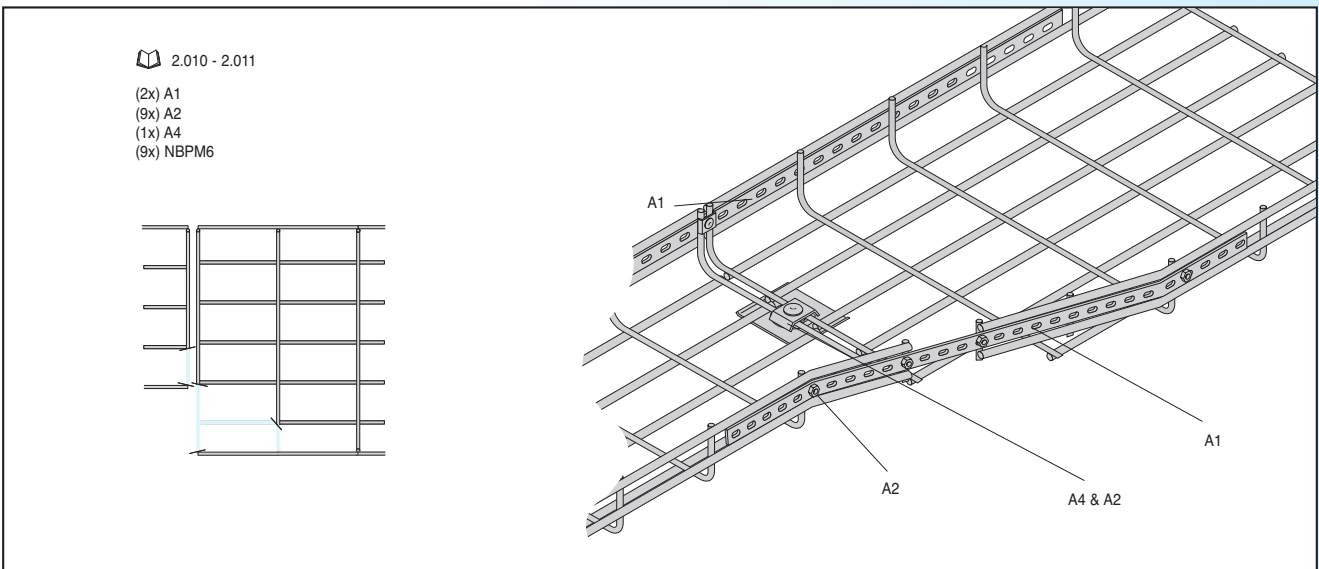
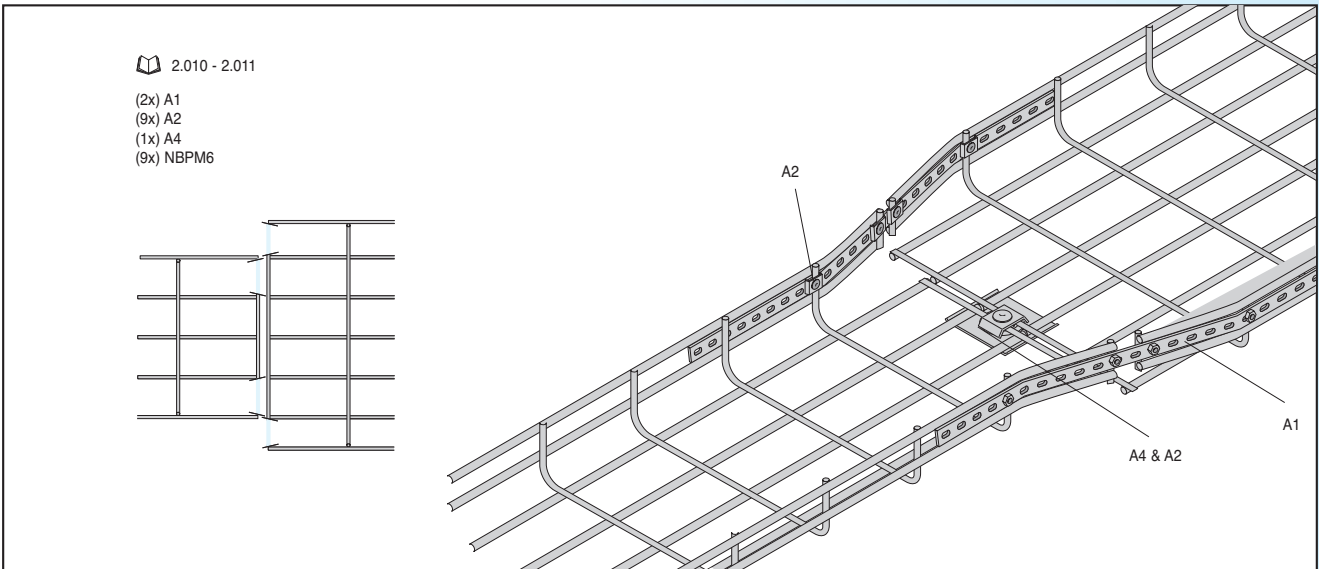

- Vertikalbogen** **D**
- Riser** **N**
- Nivåled** **S**

- Riser** **GB**
- Stijg- en vervalstukken** **NL**
- Coudes verticox** **F**

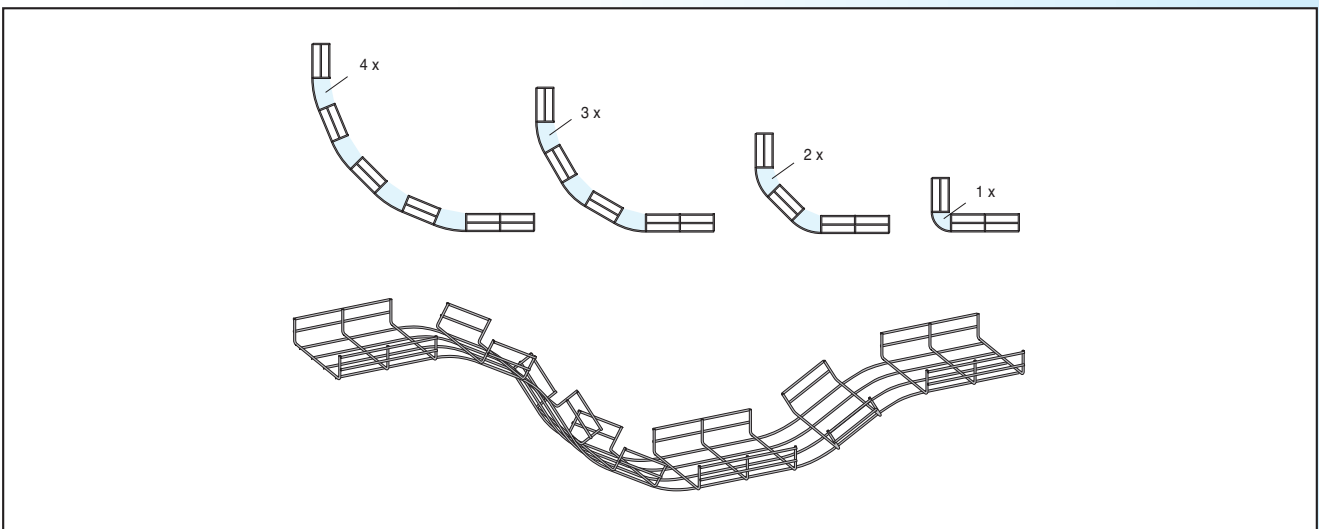

BASKET TRAY

TYCEUELSUP 0311

BASKET TRAY

- GB** Basket tray type AF
- NL** Draadgoot type AF
- F** Chemin de câbles en fil AF

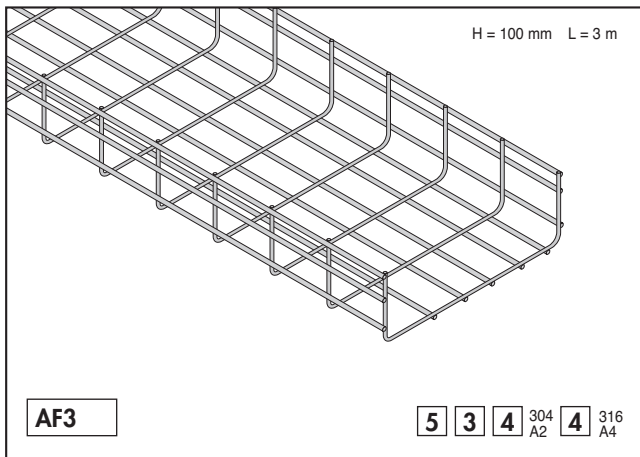
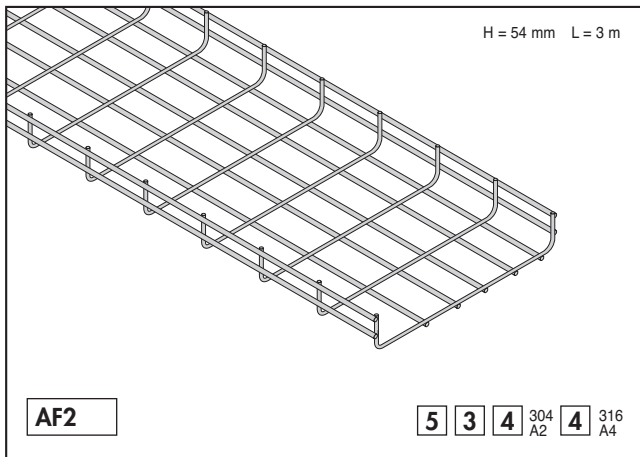
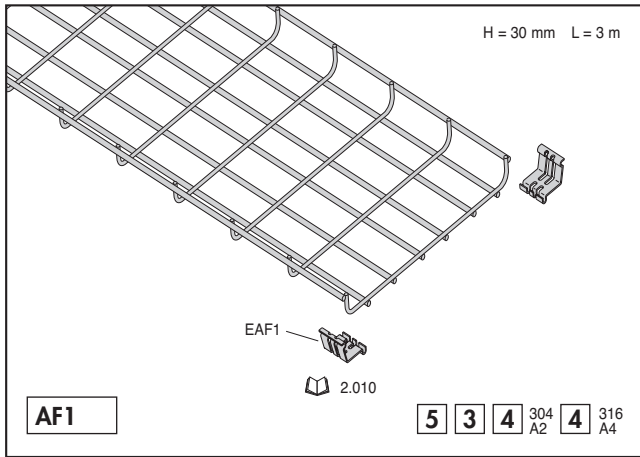

- D** Gitterrinnen Typ AF
- N** Kabelkurv type AF
- S** Nätränna typ AF

W mm	5 Art. Nr.	3 Art. Nr.	4 (304-A2) Art. Nr.	4 (316-A4) Art. Nr.
50	AC110001 0,6	AC410001 0,6	AC510001 0,6	AC610001 0,6
100	AC110002 0,8	AC410002 0,8	AC510002 0,8	AC610002 0,8
150	AC110003 1,0	AC410003 1,0	AC510003 1,0	AC610003 1,0
200	AC110004 1,2	AC410004 1,2	AC510004 1,2	AC610004 1,2
300	AC110005 1,4	AC410005 1,4	AC510005 1,4	AC610005 1,4

W mm	5 Art. Nr.	3 Art. Nr.	4 (304-A2) Art. Nr.	4 (316-A4) Art. Nr.
50	AC110013 0,8	AC410013 0,9	AC510013 0,9	AC610013 0,9
100	AC110014 1,2	AC410014 1,3	AC510014 1,3	AC610014 1,3
150	AC110015 1,4	AC410015 1,5	AC510015 1,5	AC610015 1,5
200	AC110016 1,6	AC410016 1,7	AC510016 1,7	AC610016 1,7
300	AC110017 2,3	AC410017 2,5	AC510017 2,2	AC610017 2,2
400	AC110018 3,8	AC410018 4,0	AC510018 2,7	AC610018 2,7
500	AC110019 4,8	AC410019 5,1	AC510019 3,2	AC610019 3,2

W mm	5 Art. Nr.	3 Art. Nr.	4 (304-A2) Art. Nr.	4 (316-A4) Art. Nr.
100	AC110044 1,7	AC410044 1,7	AC510044 1,7	AC610044 1,7
200	AC110046 2,3	AC410046 2,5	AC510046 2,2	AC610046 2,2
300	AC110047 3,5	AC410047 3,8	AC510047 2,7	AC610047 2,7
400	AC110048 4,8	AC410048 5,1	AC510048 3,2	AC610048 3,2
500	AC110049 6,1	AC410049 6,4	AC510049 3,7	AC610049 3,7

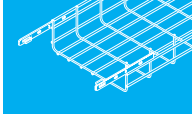

BASKET TRAY

Gitterrinnen mit angeschweißten Stoßstellenverbindern **D**
 Kabelkurv med påsveisede hurtigskjøter **N**
 Nätränna med snabbkoppling **S**

W mm	5 Art. Nr.	3 kg /M	3 Art. Nr.	3 kg /M	4 (304-A2) Art. Nr.	4 kg /M	4 (316-A4) Art. Nr.	4 kg /M
50	AC110006	0,9	AC410006	1,0	AC510006	1,0	AC610006	1,0
100	AC110007	1,3	AC410007	1,4	AC510007	1,4	AC610007	1,4
150	AC110008	1,5	AC410008	1,6	AC510008	1,6	AC610008	1,6
200	AC110009	1,7	AC410009	1,8	AC510009	1,8	AC610009	1,8
300	AC110010	2,4	AC410010	2,6	AC510010	2,3	AC610010	2,3
400	AC110011	3,9	AC410011	4,1	AC510011	2,8	AC610011	2,8
500	AC110012	4,9	AC410012	5,2	AC510012	3,3	AC610012	3,3
600	AC110021	6,2	AC410031	6,5	AC510031	3,8	AC610031	3,8

Self splicing basket tray type **GB**
 Draadgoot met automatische koppelplaten **NL**
 Chemin de câbles en fil auto-éclissable **F**

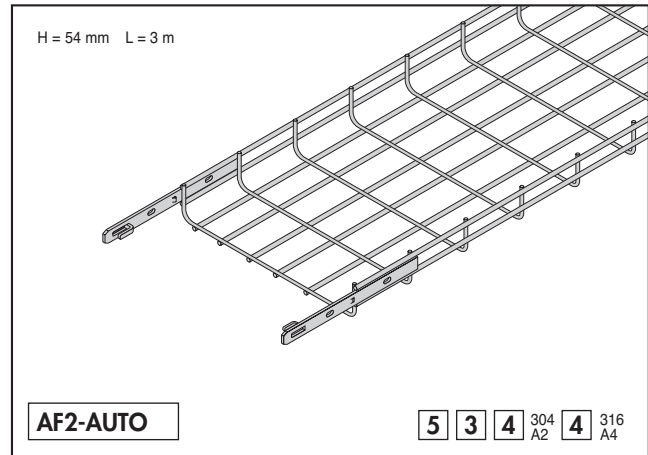

W mm	5 Art. Nr.	3 kg /M	3 Art. Nr.	3 kg /M	4 (304-A2) Art. Nr.	4 kg /M	4 (316-A4) Art. Nr.	4 kg /M
100	AC110037	1,7	AC410037	1,8	AC510037	1,8	AC610037	1,8
200	AC110039	2,4	AC410039	2,6	AC510039	2,3	AC610039	2,3
300	AC110040	3,6	AC410040	3,9	AC510040	2,8	AC610040	2,8
400	AC110041	4,9	AC410041	5,2	AC510041	3,3	AC610041	3,3
500	AC110042	6,2	AC410042	6,5	AC510042	3,8	AC610042	3,8

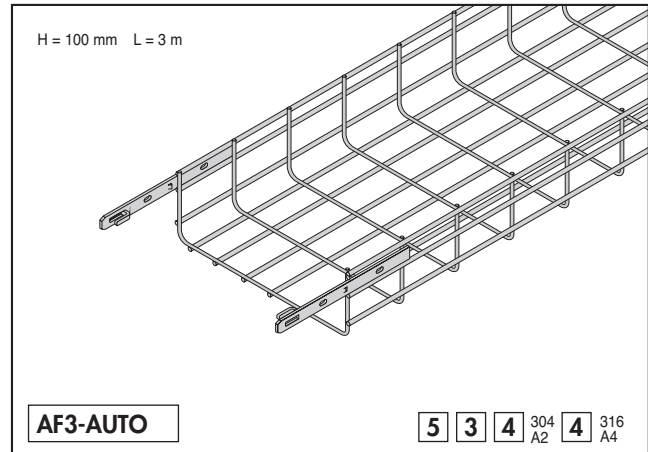

BASKET TRAY

- GB** Couplers & earthing couplers
- NL** Koppelplaten, klemmen & zadelen
- F** Eclisses, clames & cavaliers de mise à la terre

- D** Verbinders & Erdungsverbinder
- N** Skjøter og jordingsklemmer
- S** Fäst clips och jordnings clip

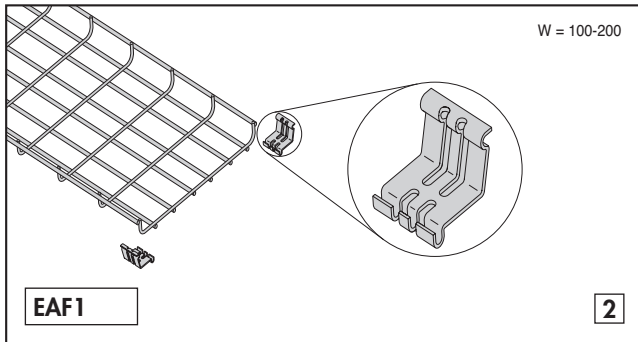

2		/100	
Art. Nr.			
AC311004	3		100

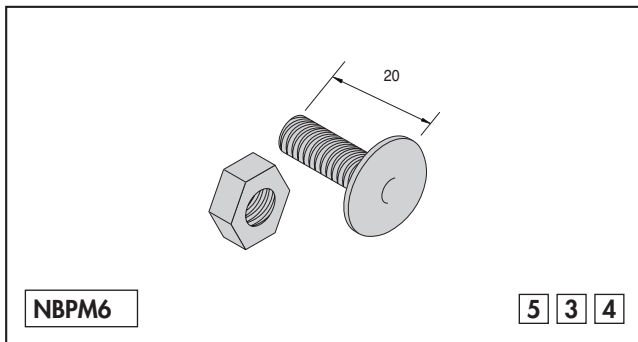

5		/100	3	Dacromet		/100	4	(316 A4)		/100	
Art. Nr.			Art. Nr.		Art. Nr.		Art. Nr.				
NBPM65	1,1		NBPM63	1,1	NBPM64	1,1					100

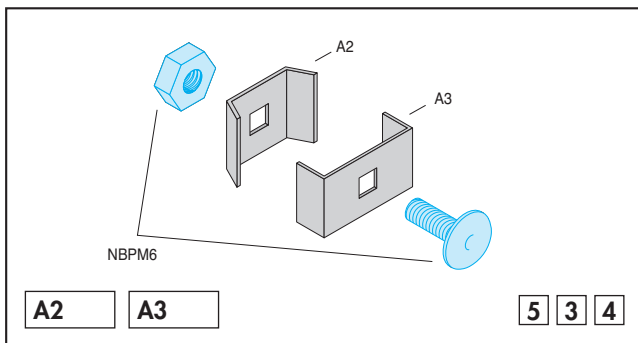

5		/100	3		/100	4	(316 A4)		/100
Art. Nr.			Art. Nr.		Art. Nr.		Art. Nr.		
A2	AC211002	0,9	AC411002	1	AC611002	0,9			
A3	AC211003	1,4	AC411003	1,5	AC611003	1,4			

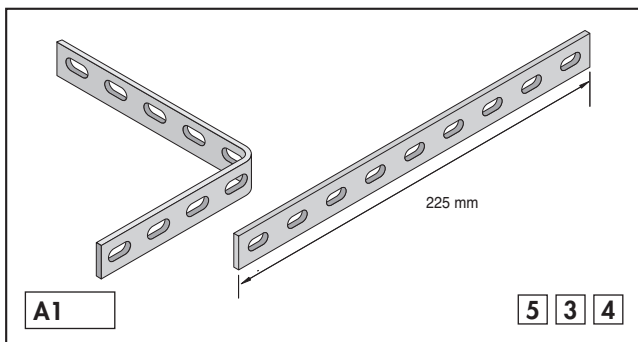

5		/100	3		/100	4	(316 A4)		/100
Art. Nr.			Art. Nr.		Art. Nr.		Art. Nr.		
AC211001	13		AC411001	13,3	AC611001	9,8			

APPLICATION EXAMPLE / MONTAGE VOORBEELD / EXEMPLE DE MONTAGE / MONTAGEBEISPIEL / EKSEMPEL PÅ MONTASJE / MONTAGE EXEMPEL

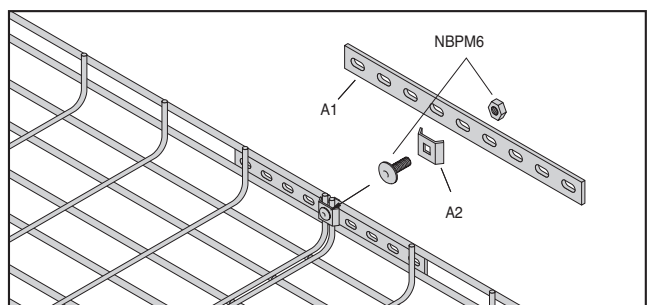
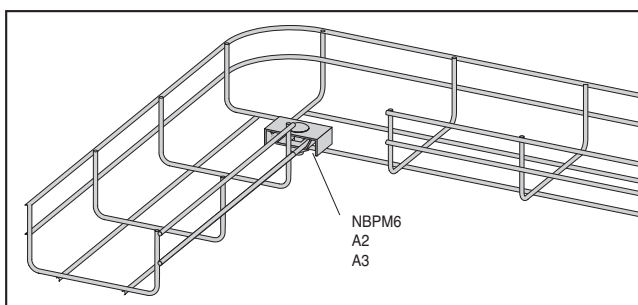

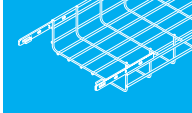

BASKET TRAY

Verbinders & Erdungsverbinders **D**
Skjøter og jordingsklemmer **N**
Kopplare och jordnings clip **S**

Couplers & earthing couplers **GB**
Koppelplaten, klemmen & zadel **NL**
Eclisses, clames & cavaliers de mise à la terre **F**

	5	3	4
Art. Nr.	Art. Nr.	Art. Nr.	Art. Nr.
A5	AC211005 65	AC411005 66	AC611005 49

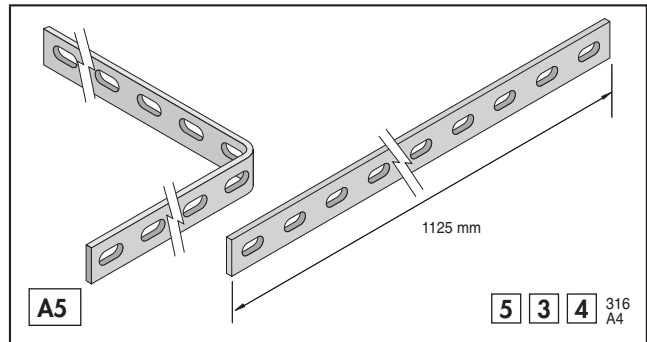

	5	3	4
Art. Nr.	Art. Nr.	Art. Nr.	Art. Nr.
A4	AC211004 4,3	AC411004 4,4	AC611004 4,5

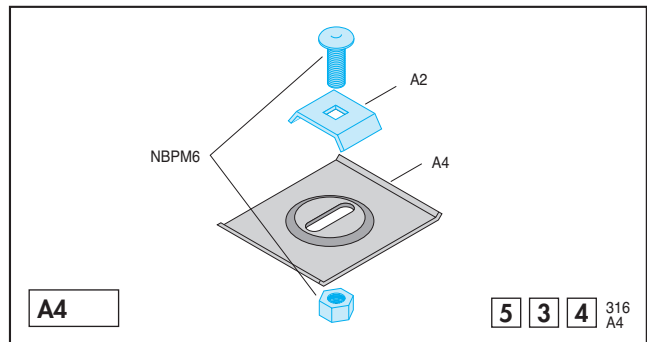

	5	3	4
Art. Nr.	Art. Nr.	Art. Nr.	Art. Nr.
AC211006	1	AC411006 1,1	AC611006 1,2

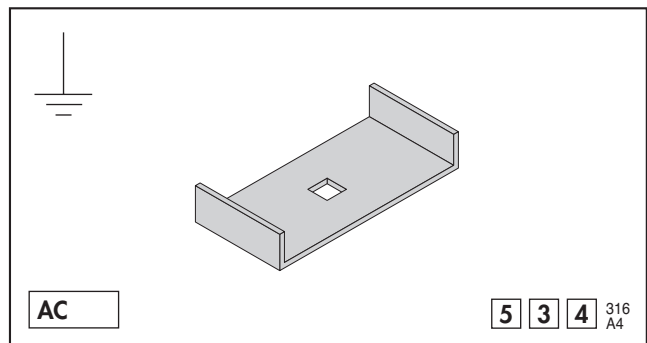

Art. Nr.	/100
WIRECUTTER	116

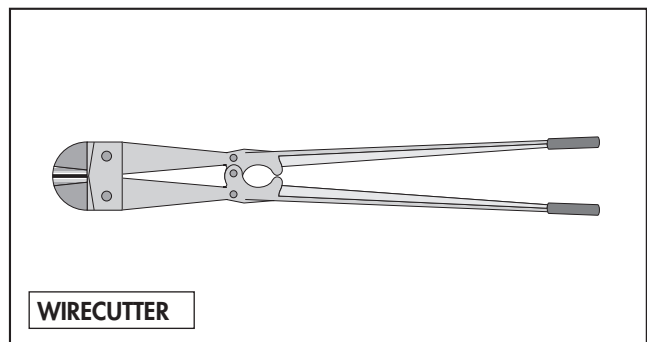

APPLICATION EXAMPLE / MONTAGE VOORBEELD / EXEMPLE DE MONTAGE / MONTAGEBEISPIEL / EKSEMPEL PÅ MONTASJE / MONTAGE EXEMPEL

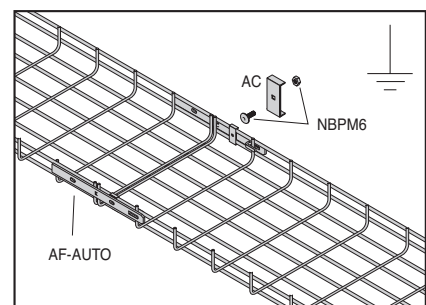
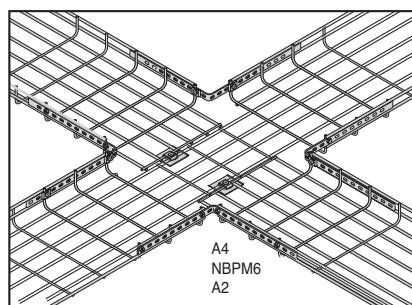
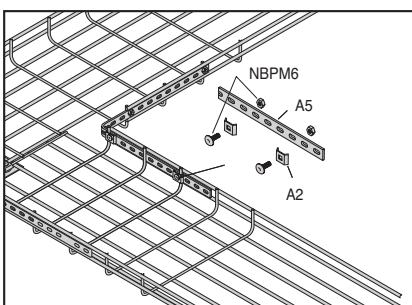

BASKET TRAY

TYCEUELSUP 0311

BASKET TRAY

GB Cover (snap on type)

NL Deksel (kliksluiting)

F Couvercle (encliquetable)

D Schnappdeckel

N Dekklokk (hurtigkobling)

S Täck kåpa

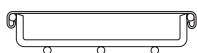
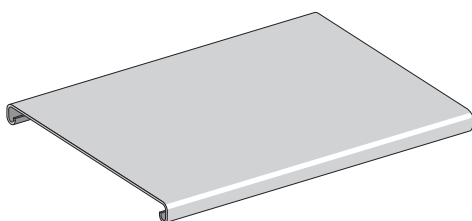

AF1



AF2



AF3

AF-C

2 3 4 316 A4

W (mm)	2		3		4 (316-A4)	
	Art. Nr.	kg / M	Art. Nr.	kg / M	Art. Nr.	kg / M
50	AC319006	0,8	AC419006	0,9	AC619006	0,8
100	AC319007	1,2	AC419007	1,3	AC619007	1,2
150	AC319008	1,6	AC419008	1,7	AC619008	1,6
200	AC319009	2	AC419009	2,1	AC619009	2
300	AC319010	2,8	AC419010	3	AC619010	2,8
400	AC319011	5,4	AC419011	5,8	AC619011	5,4
500	AC319012	6,6	AC419012	7	AC619012	6,6
600	AC319021	8,0	AC419021	8,4	AC619021	8,0

GB Tray divider with hooks

NL Scheidingsschot met bevestigingshaken

F Séparation rail à ergots

D Trennsteg mit Schnappverschluss

N Skillevegg med hurtigkobling

S Skiljeplåt

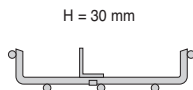
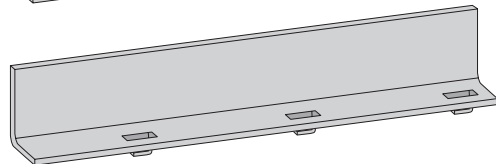
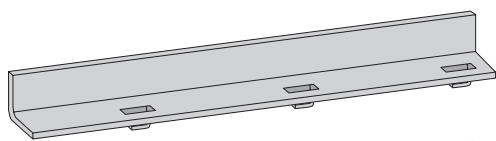

H = 30 mm

AF1

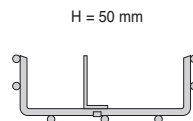

H = 50 mm

AF2

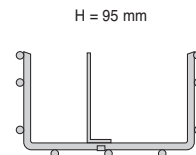

H = 95 mm

AF3

AF-D

2 3 4 316 A4

H (mm)	2		3		4 (316-A4)	
	Art. Nr.	kg / M	Art. Nr.	kg / M	Art. Nr.	kg / M
30	AC310020	0,6	AC410020	0,6	AC610020	0,6
50	AC310021	0,8	AC410021	0,9	AC610021	0,8
95	AC310023	1,6	AC410023	1,6	AC610023	1,6

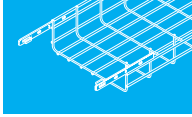

BASKET TRAY

Eckstück 90° **D**
 90° bend **N**
 Böj 90° **S**

Preformed bend 90° **GB**
 Platte bocht 90° **NL**
 Coude 90° **F**

H = 54 mm

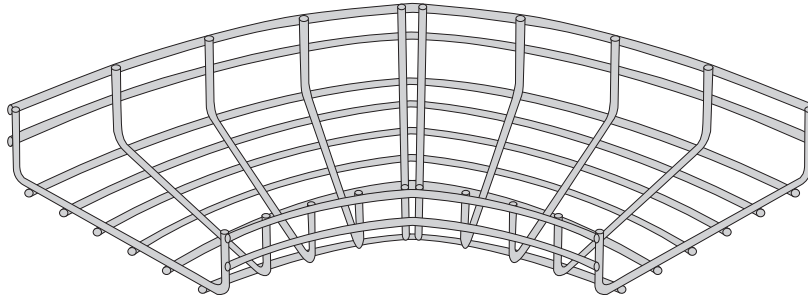

C-AF2

5 3

W mm	5 Art. Nr.	kg	3 Art. Nr.	kg
200	AC113009	1,0	AC413009	1,1
300	AC113010	2,0	AC413010	2,1
400	AC113011	3,5	AC413011	3,7
500	AC113012	4,5	AC413012	4,8

Abgangsblech **D**
 Nedføring **N**
 Dropp plåt **S**

Drop out **GB**
 Kabel uitgangplaat **NL**
 Sortie de câbles **F**

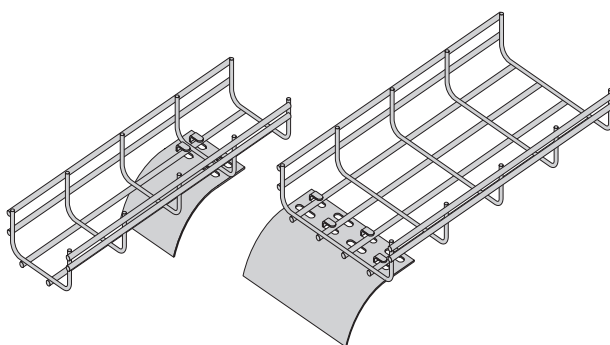

W = 100 mm

W = 200 mm

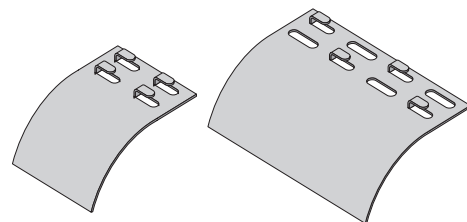

AF-DO

2

Art. Nr.	W (mm)	kg
AC312091	100	0,2
AC312090	200	0,4

BASKET TRAY

TYCEUELSUP 0311

BASKET TRAY

- GB** Cantilever arm type ACF
- NL** Konsoles type ACF
- F** Consoles ACF

- D** Konsole Typ ACF
- N** Konsoll type ACF
- S** Konsol typ AFC

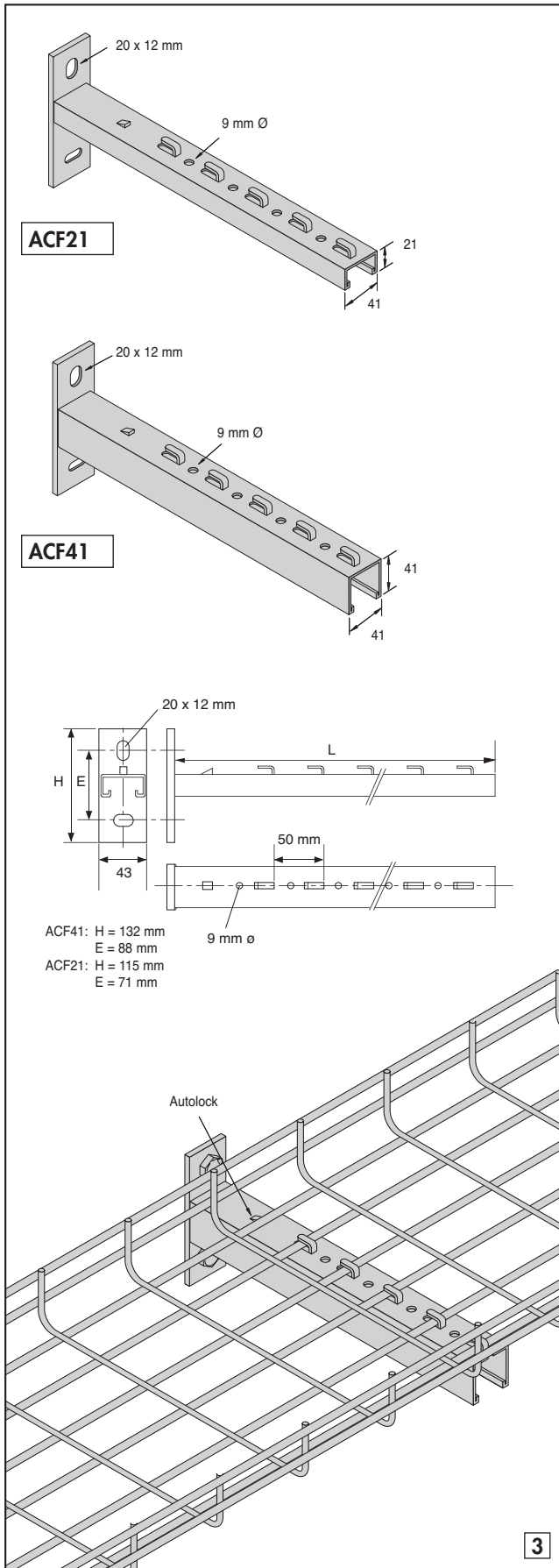

	W (mm)	L (mm)	Fmax (kN)	3 Art. Nr.	Kg/m
ACF 21	150	200	1,20	AC432041	0,57
ACF 21	200	250	1,00	AC432042	0,66
ACF 21	300	350	0,70	AC432044	0,84

	W (mm)	L (mm)	Fmax (kN)	3 Art. Nr.	Kg/m
ACF 41	200	250	2,50	AC432052	0,88
ACF 41	300	350	2,00	AC432053	1,12
ACF 41	400	450	1,50	AC432054	1,38
ACF 41	500	550	1,30	AC432055	1,62
ACF 41	600	650	1,10	AC432056	1,88

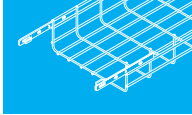

BASKET TRAY

Montageprofil mit Befestigungshaken **D**
 Skinne med kroker **N**
 Skenor med hakar **S**

	L (m)	2		3	
		Art. Nr.	Kg/m	Art. Nr.	Kg/m
HS21 21 x 41	6	AC335020	1,8	AC435020	1,90
HS21 21 x 41	3	AC335019	1,8	AC435019	1,90

	L (m)	2		3	
		Art. Nr.	Kg/m	Art. Nr.	Kg/m
HS41 41 x 41	6	AC335010	2,5	AC435010	2,65
HS41 41 x 41	3	AC335009	2,5	AC435009	2,65

2		3	
Art. Nr.	Kg	Art. Nr.	Kg
AC334053	0,3	AC434053	0,3

Channel with hooks **GB**
 Montageprofil met bevestigingshaken **NL**
 Rails à ergots **F**

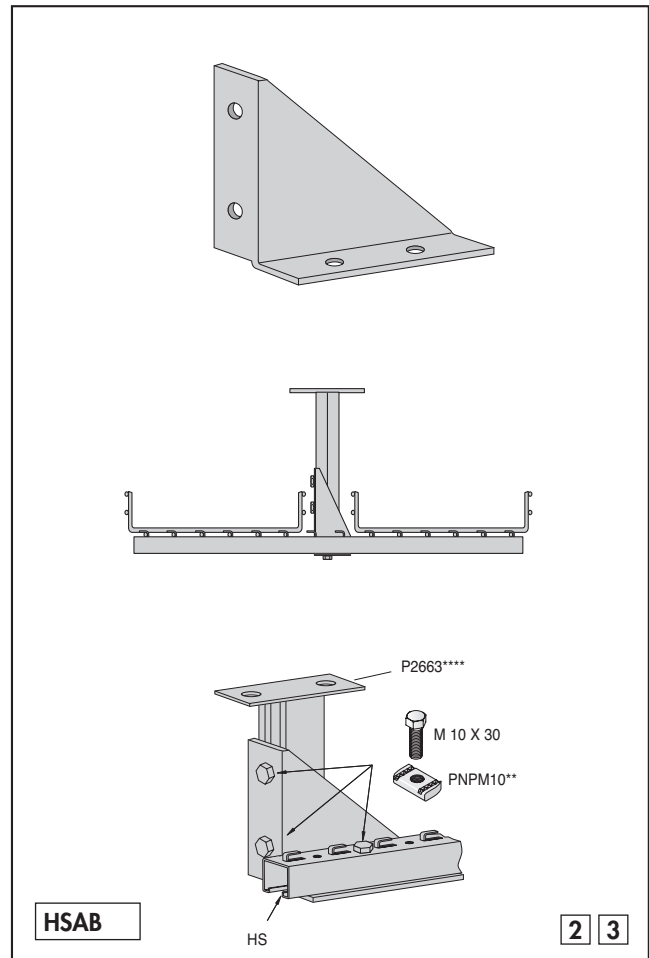
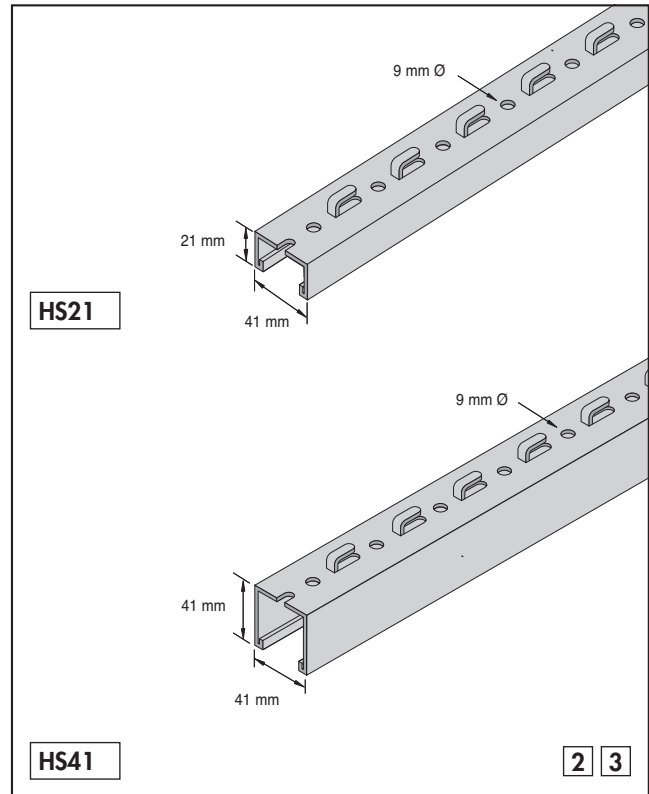

BASKET TRAY

TYCEUELSUP 0311

BASKET TRAY

- GB** Medium duty cantilever arm for basket tray
- NL** Middelzware konsole voor draadgoot
- F** Console légère à ergots et butée d'encliquetage pour chemin de câbles en fil

- D** Mittelschwere Tragkonsole für Gitterrinnen mit Schnappverschluss
- N** Medium konsoll for kabelkurv
- S** Konsol medium för nätrännor

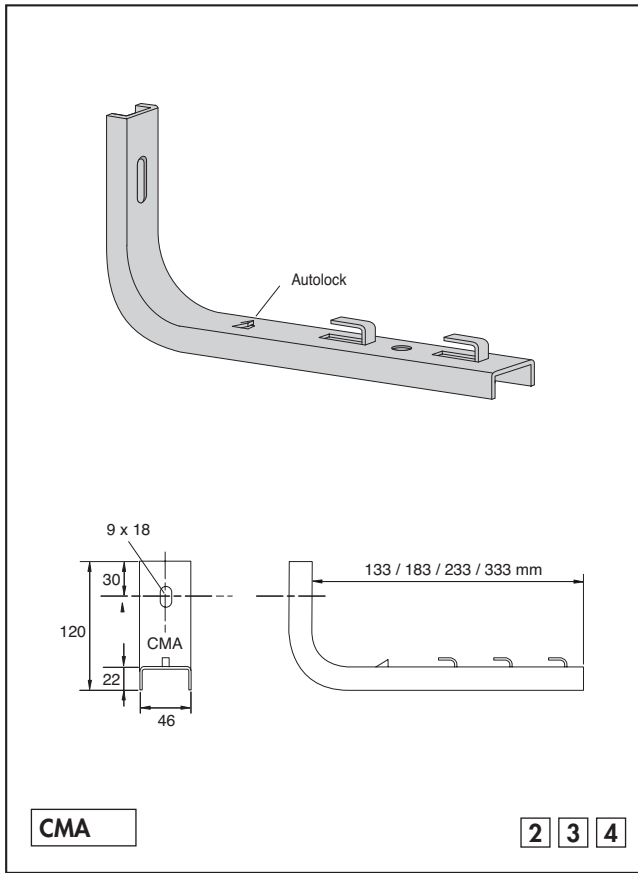

L (mm)	Fmax N	2 Art. Nr.	2	3 Art. Nr.	3	4 ³¹⁶ _{A4} Art. Nr.	4
100	1600	AC312080	0,36	AC412080	0,38	AC612080	0,36
150	1200	AC312081	0,44	AC412081	0,47	AC612081	0,44
200	800	AC312082	0,52	AC412082	0,56	AC612082	0,52
300	600	AC312083	0,68	AC412083	0,73	AC612083	0,68

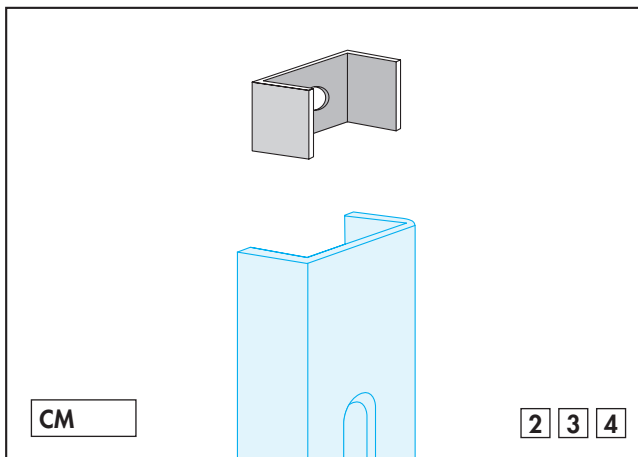

2 Art. Nr.	2	3 Art. Nr.	3	4 Art. Nr.	4
AC312089	0,02	AC412089	0,03	AC612089	0,03

APPLICATION EXAMPLE / MONTAGE VOORBEELD / EXEMPLE DE MONTAGE / MONTAGEBEISPIEL / EKSEMPEL PÅ MONTASJE / MONTAGE EXEMPEL

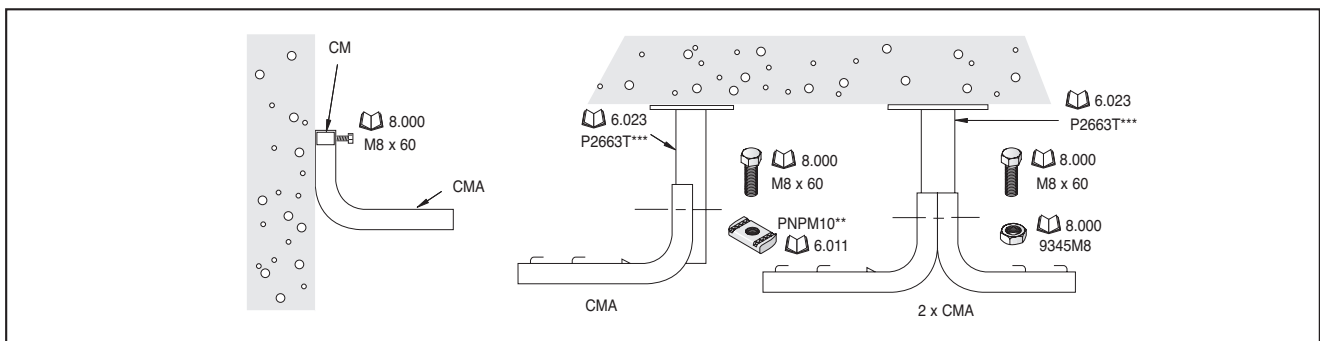

TYCEUELSUP 0311

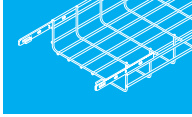

BASKET TRAY

Leichte Tragkonsole für Gitterrinnen mit Schnappverschluss für Deckenmontage **D**

Lett konsoll C for kabelkurv **N**

Lättvikts konsol för nätrännor **S**

L (mm)	Fmax N	2 Art. Nr.	3 Art. Nr.	4 316 A4 Art. Nr.	3 Art. Nr.	4 316 A4 Art. Nr.	3 Art. Nr.
100	800	AC312065	0,33	AC412065	0,35	AC612065	0,33
150	600	AC312066	0,38	AC412066	0,41	AC612066	0,38
200	400	AC312067	0,43	AC412067	0,46	AC612067	0,43

Light duty C bracket for basket tray **GB**

Lichte C beugel voor draadgoot **NL**

Pendard en cé à ergots et butée d'encliquetage pour chemin de câbles en fil **F**

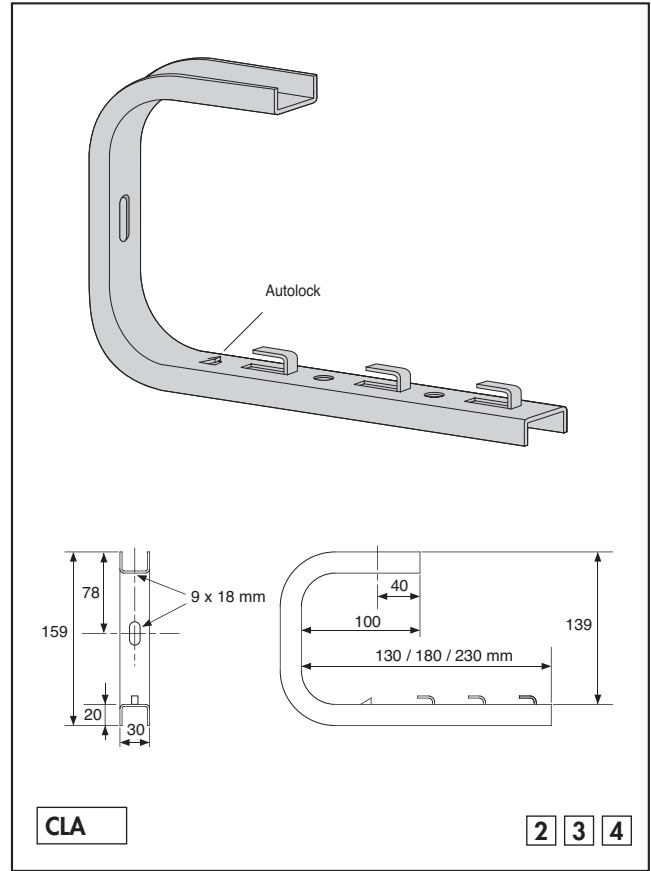

BASKET TRAY

2 Art. Nr.	3 Art. Nr.	4 Art. Nr.
AC302069 0,02	AC402609 0,03	AC602069 0,03

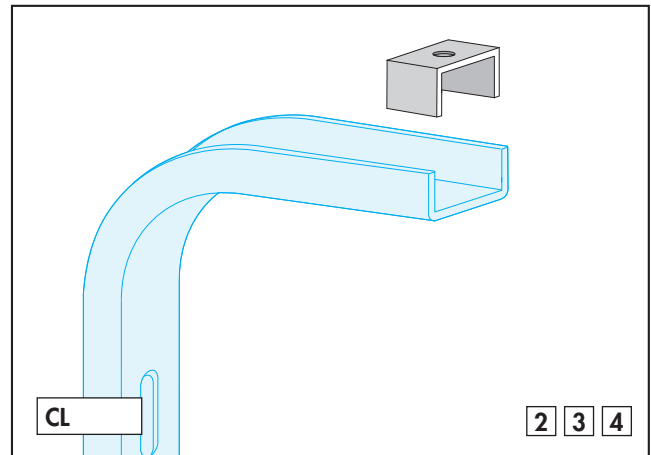

BASKET TRAY

- GB** Auto fix cantilever arm for basket tray
- NL** Konsole met snelbevestigingshaken voor draadgoot
- F** Consoles profilées à ergots et butée d'encliquetage pour chemin de câbles en fil

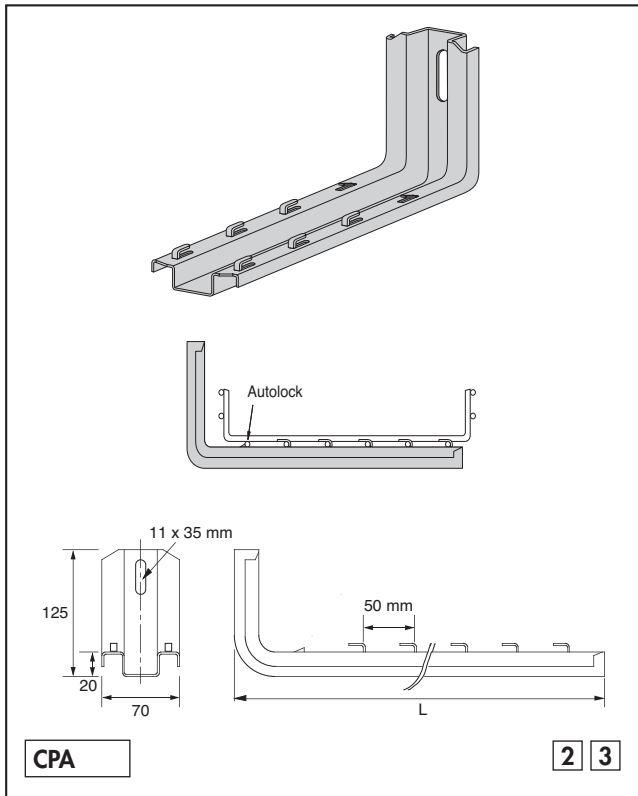

- D** Tragkonsole für Gitterrinnen mit Schnappverschluss
- N** Konsoll for hurtigmontering av kabelkurv
- S** Konsol för snabbmontage

W (mm)	L (mm)	Fmax (kN)	2 Art. Nr.	kg	3 Art. Nr.	kg
150	195	1,5	AC312011	0,44	AC412011	0,47
200	245	1,0	AC312012	0,52	AC412012	0,55
300	345	0,9	AC312013	0,67	AC412013	0,71
400	445	0,4	AC312014	0,82	AC412014	0,87

- GB** C shaped support for basket tray
- NL** C beugel voor draadgoot
- F** Pendar en cé avec ergots et butée d'encliquetage pour chemin de câbles en fil

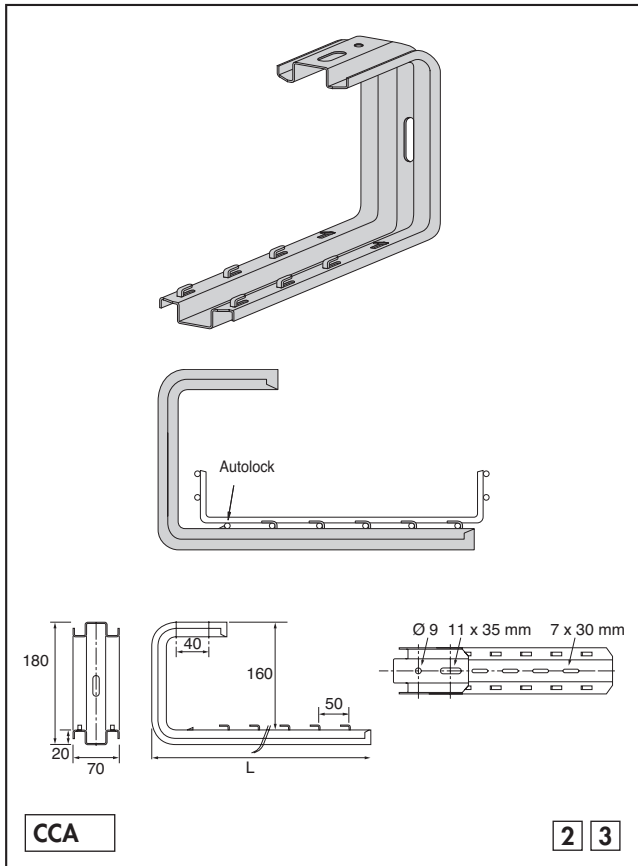

- D** Tragkonsole für Gitterrinnen mit Schnappverschluss für Deckenmontage
- N** C format konsoll for kabelkurv
- S** C-format konsol för snabbmontage

W (mm)	L (mm)	Fmax (kN)	2 Art. Nr.	kg	3 Art. Nr.	kg
100	185	1,2	AC312020	0,59	AC412020	0,63
150	195	1,0	AC312021	0,67	AC412021	0,71
200	245	0,9	AC312022	0,75	AC412022	0,80
300	345	0,8	AC312023	0,9	AC412023	0,95
400	445	0,4	AC312024	1,05	AC412024	1,11



BASKET TRAY

Hängestiele für Tragkonsole Typ CPA **D**

Kraftig takfeste for bruk med konsoller type CPA og CPP **N**

Takonsol för användning med konsoler CPA & CPP **S**

Heavy ceiling bracket for use with cantilevers **GB**

Hangkonsole voor beugels CPA & CPP **NL**

Montant profilé pour confection de pendards avec consoles CPA ou CPP **F**

H (mm)	2 Art. Nr.	Ⓜ Kg	3 Art. Nr.	Ⓜ Kg
150	AC312041	0,32	AC412041	0,34
250	AC312042	0,45	AC412042	0,48
350	AC312043	0,58	AC412043	0,61
450	AC312044	0,71	AC412044	0,75
550	AC312045	0,84	AC412045	0,89
650	AC312046	0,97	AC412046	1,03

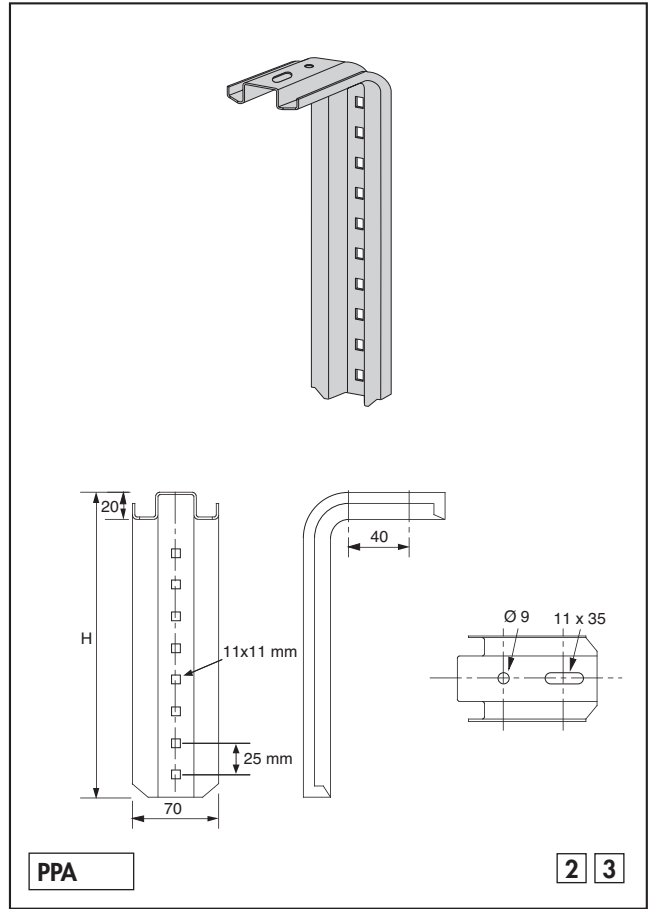

BASKET TRAY

APPLICATION EXAMPLE / MONTAGE VOORBEELD / EXEMPLE DE MONTAGE / MONTAGEBEISPIEL / EKSEMPEL PÅ MONTASJE / MONTAGE EXEMPEL

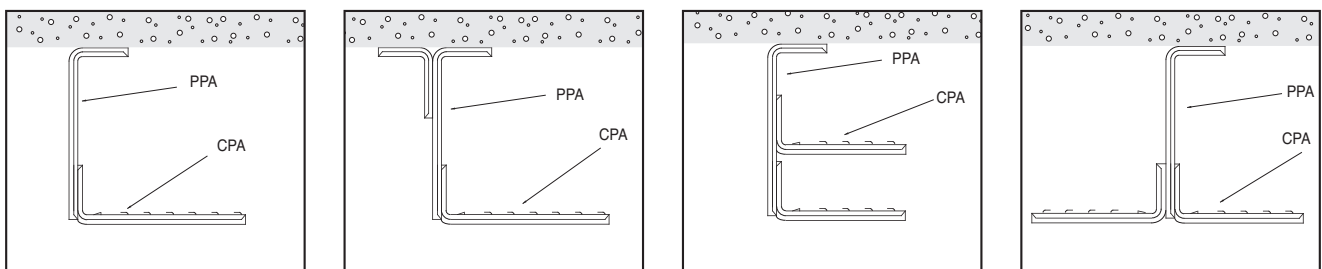

TYCEUELSUP 0311

BASKET TRAY

- GB** Supports
- NL** Bevestigingsystemen
- F** Système de supportage

- D** Zubehör
- N** Oppheng
- S** Tillbehör

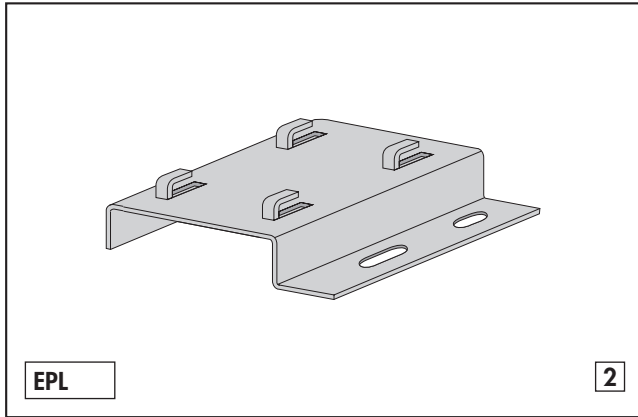

Art. Nr.	/100	
AC312030	15	50

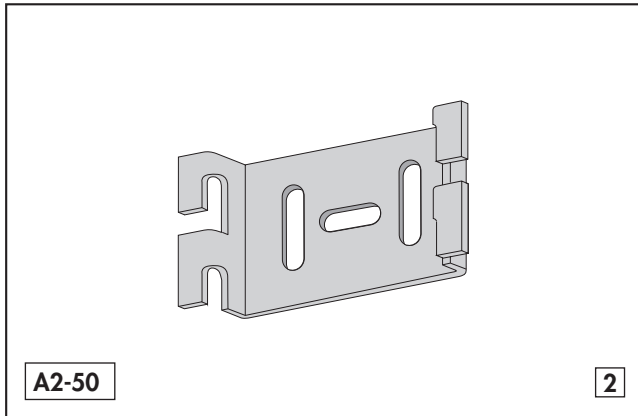

Art. Nr.	/100	
AC312002	10	50

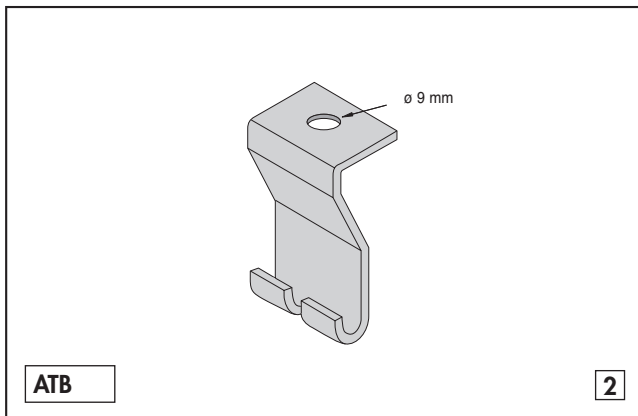

Art. Nr.	/100	
AC312003	6	50

APPLICATION EXAMPLE / MONTAGE VOORBEELD / EXEMPLE DE MONTAGE / MONTAGEBEISPIEL / EKSEMPEL PÅ MONTASJE / MONTAGE EXEMPEL

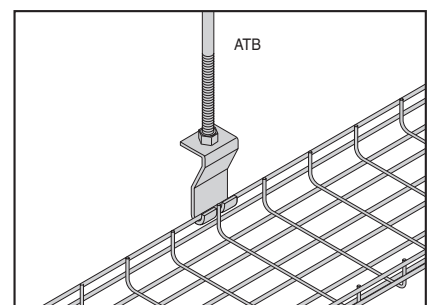
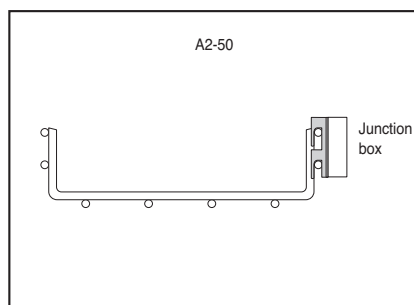
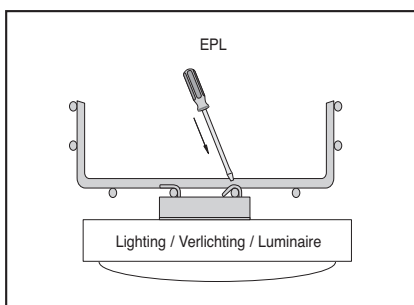

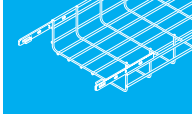

BASKET TRAY

Aufhängebügel **D**

Hengebrakett **N**

Öppna c- byglar för nätrännor **S**

Hanging bracket for tray **GB**

Open C beugel voor draadgoot **NL**

Suspente **F**

2		3		4 (316-L)	
Art. Nr.	kg	Art. Nr.	kg	Art. Nr.	kg
AC312009	0,20	AC412009	0,21	AC612009	0,15

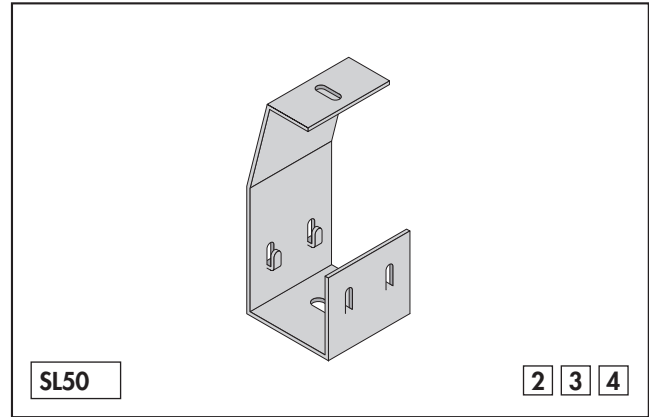

2		3		4 (316-L)	
Art. Nr.	kg	Art. Nr.	kg	Art. Nr.	kg
AC312015	0,13	AC412015	0,14	AC612015	0,10

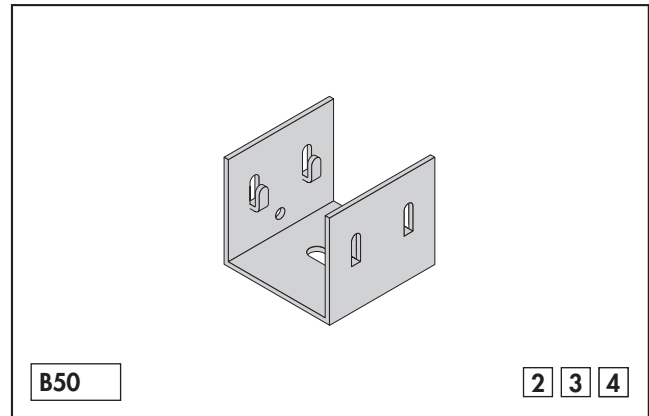

2		3		4 (316-L)	
Art. Nr.	kg	Art. Nr.	kg	Art. Nr.	kg
AC312019	0,45	AC412019	0,48	AC612019	0,38

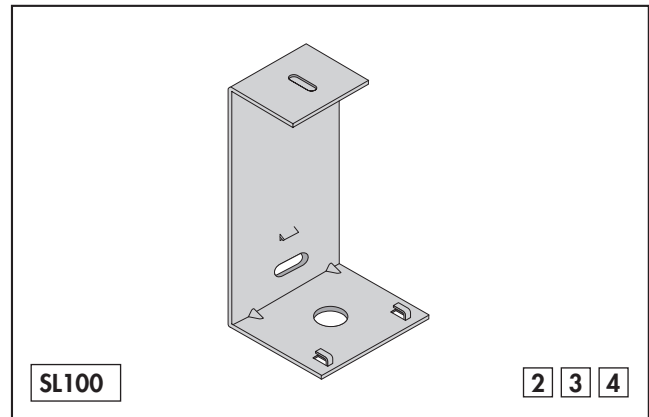

BASKET TRAY

APPLICATION EXAMPLE / MONTAGE VOORBEELD / EXEMPLE DE MONTAGE / MONTAGEBEISPIEL / EKSEMPEL PÅ MONTASJE / MONTAGE EXEMPEL

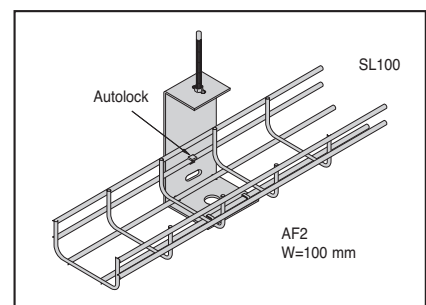
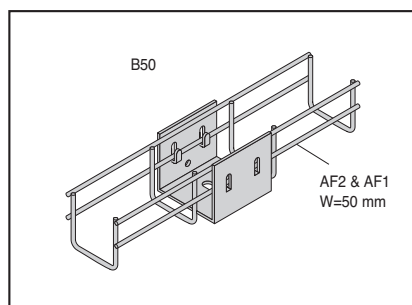
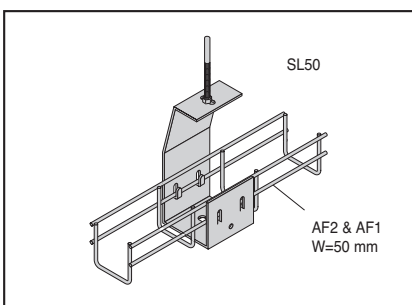

TYCEUELSUP 0311

BASKET TRAY

GB Load data

NL Belastinggegevens

F Charges admissibles

D Belastungswerte

N Belastningsdata

S Belastnings data

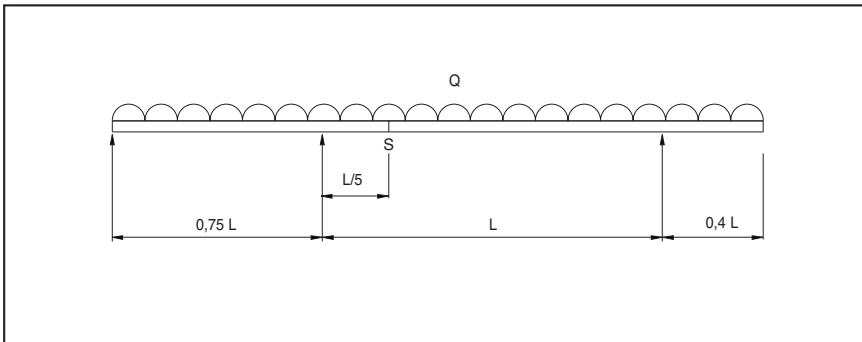

GB Load test according CEI/IEC 61537:2001

Q = UDL (uniformly distributed load)

Safety Factor = 1,7

L = intermediate span

F = deflection = 1/100 of the intermediate span (max.)

S = splice location

NL Belastingtest volgens CEI/IEC 61537:2001

Q = gelijkmatig verdeelde belasting

Veiligheidsfactor = 1,7

L = overspanning

F = doorbuiging = 1/100 van de overspanning (maximaal)

S = locatie van de koppelplaten

F Essai de charge suivant CEI/IEC 61537:2001

Q = CUR (charge uniformement repartie)

Coefficient de sécurité = 1,7

L = portée

F = flèche = 1/100 de la portée (max.)

S = position des éclisses

D Belastungsprüfung gemäß CEI/IEC 61537:2001

Q = Gleichlast

Sicherheitsbeiwert = 1,7

L = Stützabstand

F = Durchbiegung = 1/100 der Überspannung

S = Verbindungsstelle

N Testet i henhold til CEI/IEC 61537:2001

Q = jevnt fordelt last

Sikkerhetsfaktor 1,7

L = Avstand mellom oppheng

F = nedbøyning = 1/100 av opphengsavstand

S = plassering av skjot

S Belastnings test CEI/IEC 61537:2001

Q = Likformigt fördelad last med en

Säkerhetsfaktor 1.7

L = Avstånd mellan fästpunkterna

F = Nedböjning = 1/100 av avståndet mellan fästpunkterna

S = Skarv punkt

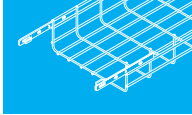

BASKET TRAY

Belastungsdiagramme **D**
 Belastningsdata **N**
 Belastnings data **S**

Load data **GB**
 Belastingsgegevens **NL**
 Charges admissibles **F**

W (mm)	A (cm ²)
50	12,75
100	25,5
150	38,25
200	51
300	75

- A **GB** Useful cross section
NL Max. vulling
F Capacité maximale
D Nutzquerschnitt
N Nyttbart tversnitt
S Maximal belastning

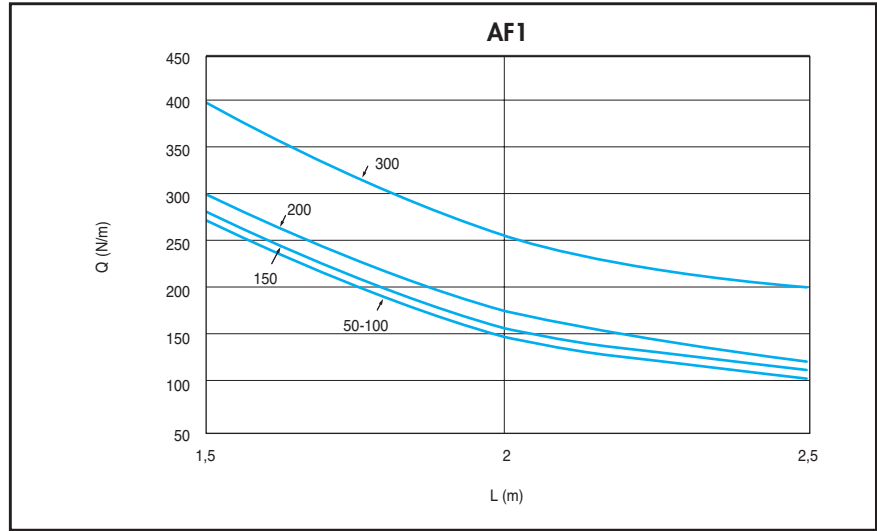

W (mm)	A (cm ²)
50	24,75
100	49,5
150	74,25
200	99
300	147
400	192
500	240
600	288

- A **GB** Useful cross section
NL Max. vulling
F Capacité maximale
D Nutzquerschnitt
N Nyttbart tversnitt
S Maximal belastning

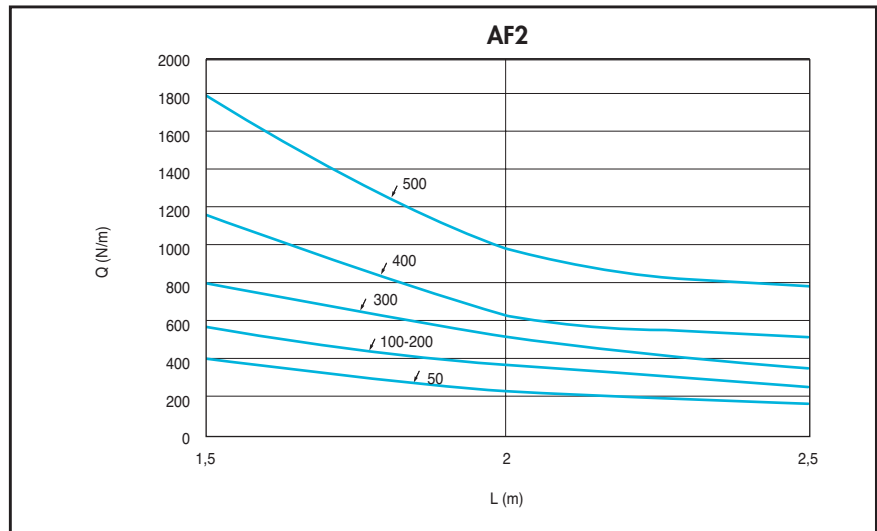

W (mm)	A (cm ²)
100	95,5
200	191
300	285
400	376
500	470

- A **GB** Useful cross section
NL Max. vulling
F Capacité maximale
D Nutzquerschnitt
N Nyttbart tversnitt
S Maximal belastning

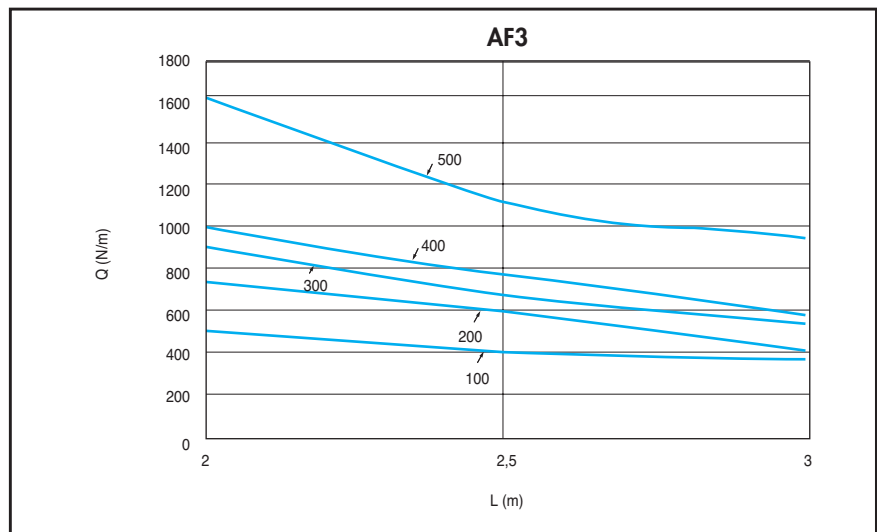

BASKET TRAY

TYCEUELSUP 0311

CABLE LADDER

- GB** Standard dimensions
- NL** Standaard afmetingen
- F** Dimensions standard

- D** Standardabmessungen
- N** Standard dimensjoner
- S** Standard dimensioner

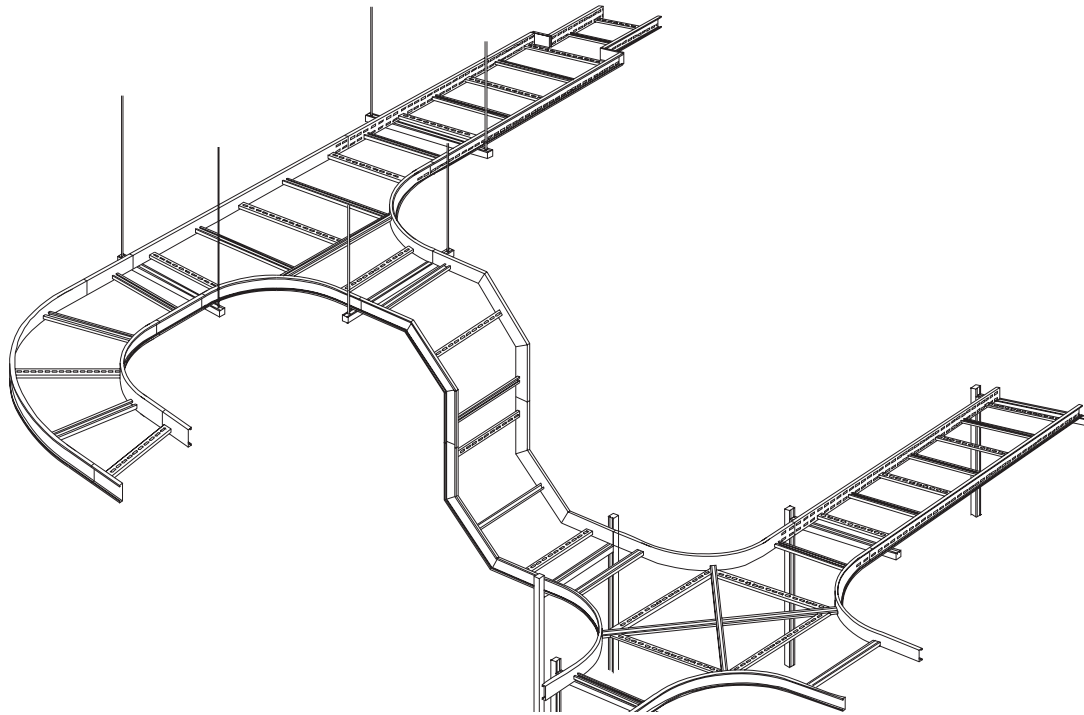

- GB** Rung distance
- NL** Sport afstand
- F** Distance des échelons

- D** Sprossenabstand
- N** Avstand mellom trinn
- S** Avstånd stegpinnar

- GB** Rung dimensions
- NL** Afmeting sporten
- F** Dim. échelons

- D** Sprossenabmessungen
- N** Dimensjoner på trinn
- S** Mått stegpinnar

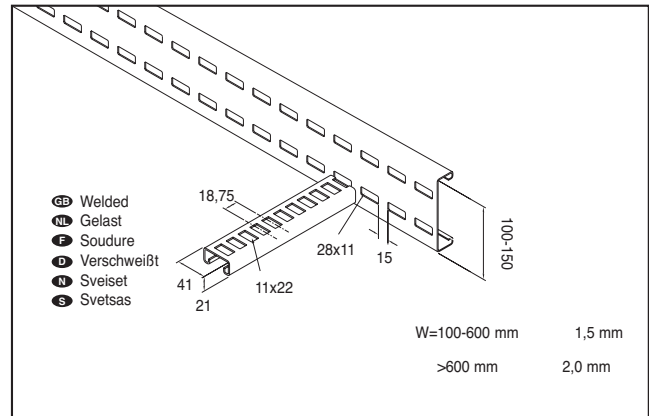
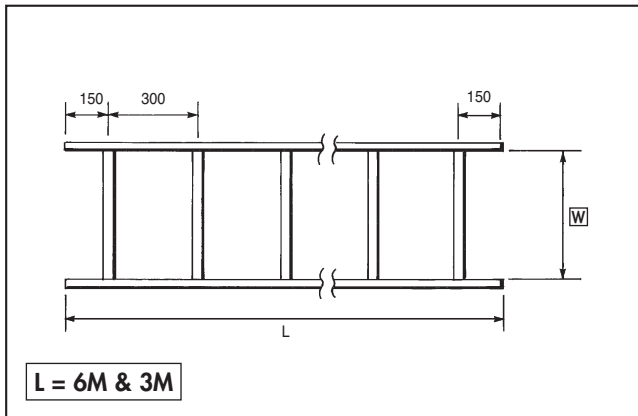

- GB** Fitting radius
- NL** Radius hulpstuk
- F** Courbe de raccordement

- D** Radius
- N** Radius på bend
- S** Byggmått

- GB** Possible widths
- NL** Breedte maten
- F** Langueurs

- D** Breiten
- N** Tilgjengelige bredder
- S** Brädder

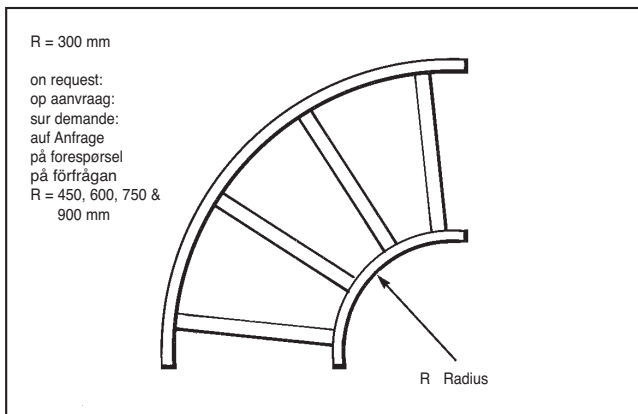

W	Width / Breedte / Largeur / Breite / Bredd / Bredd
10	= 100 mm
15	= 150 mm
20	= 200 mm
30	= 300 mm
40	= 400 mm
45	= 450 mm
50	= 500 mm
60	= 600 mm
75	= 750 mm
80	= 800 mm
90	= 900 mm
00	= 1000 mm

CABLE LADDER

Kabelleitern **D**
 Kabelstige **N**
 Kabelstege **S**

Cable ladder **GB**
 Kabelladder **NL**
 Echelles a câbles **F**

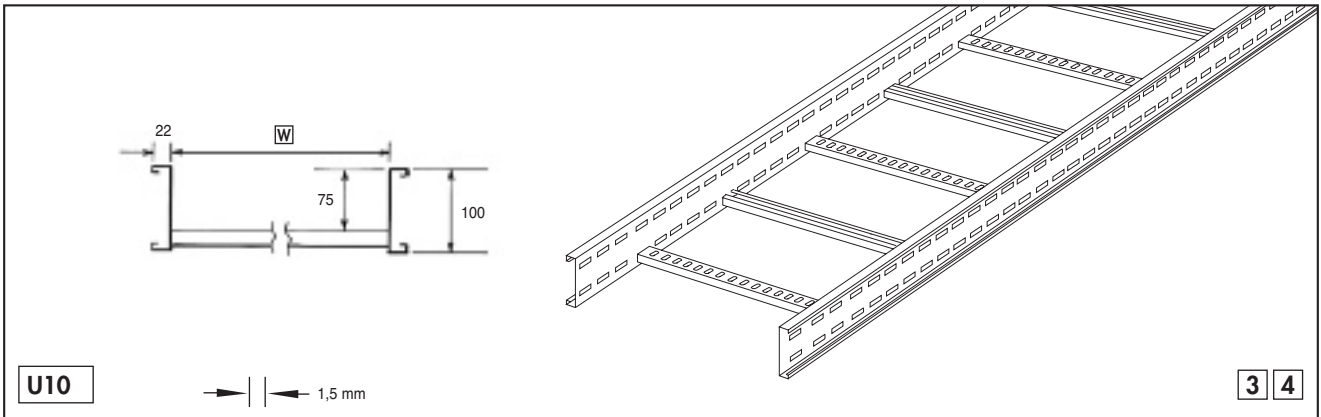

L=3m.		L=6m	
3	4	3	4
Art. Nr.	Art. Nr.	Art. Nr.	Art. Nr.
U103 W 3	U103 W 4	U106 W 3	U106 W 4

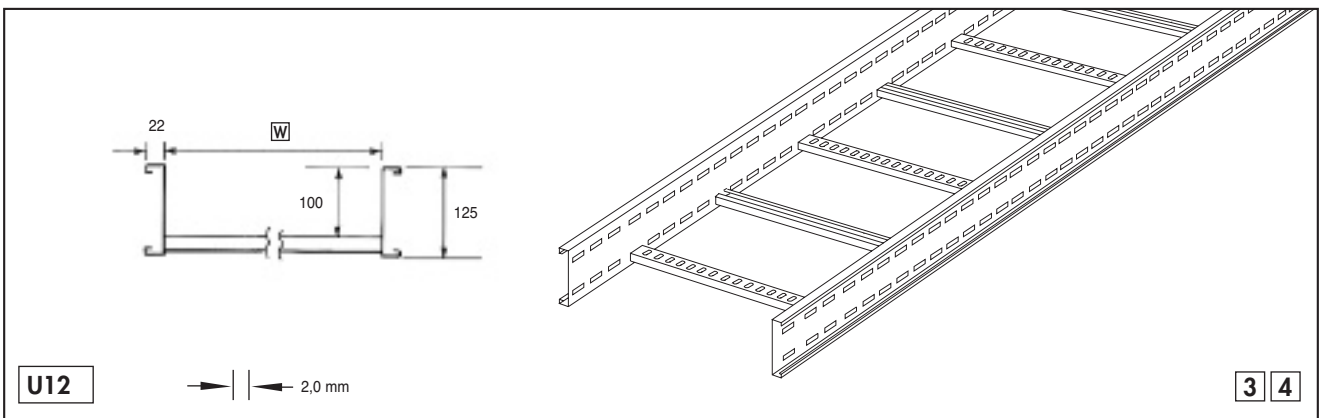

L=3m.		L=6m	
3	4	3	4
Art. Nr.	Art. Nr.	Art. Nr.	Art. Nr.
U123 W 3	U123 W 4	U126 W 3	U126 W 4

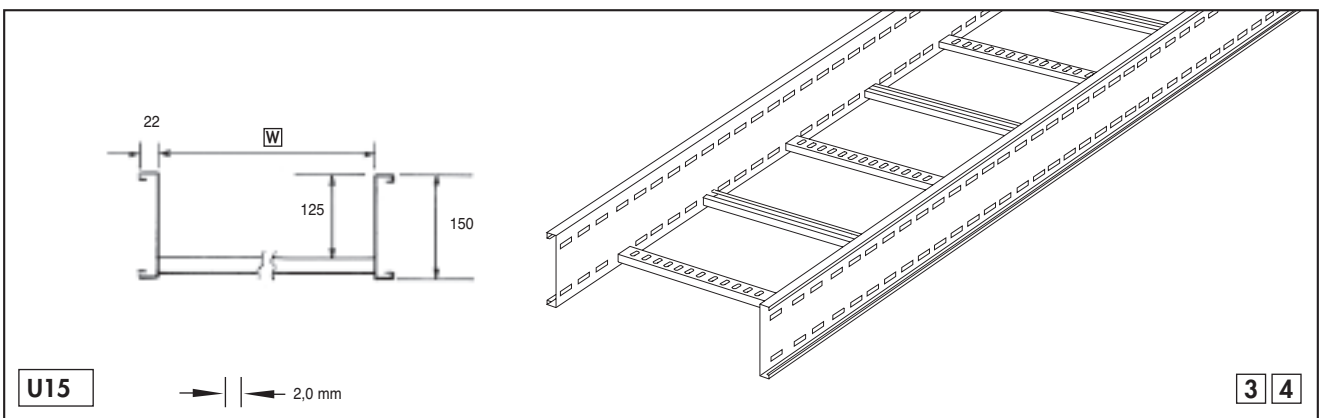

L=3m.		L=6m	
3	4	3	4
Art. Nr.	Art. Nr.	Art. Nr.	Art. Nr.
U153 W 3	U153 W 4	U156 W 3	U156 W 4

CABLE LADDER

TYCEUELSUP 0311

CABLE LADDER

- GB** Flat bend 90° & 45°
- NL** Platte bocht 90° & 45°
- F** Coude plat 90° & 45°

- D** Bogen 90° & 45°
- N** Bend 90° og 45°
- S** Flat vinkel 90° & 45°

90° R=300mm

U10		U12		U15	
3	4	3	4	3	4
Art. Nr.	Art. Nr.	Art. Nr.	Art. Nr.	Art. Nr.	Art. Nr.
U10B W 3	U10B W 4	U12B W 3	U12B W 4	U15B W 3	U15B W 4

45° R=300mm

U10		U12		U15	
3	4	3	4	3	4
Art. Nr.	Art. Nr.	Art. Nr.	Art. Nr.	Art. Nr.	Art. Nr.
U10B W 453	U10B W 454	U12B W 453	U12B W 454	U15B W 453	U15B W 454

CABLE LADDER

T-Stück & Kreuzstück **D**
 T-stykke og kryss **N**
 -Avgrening & X-Avgrening **S**

Equal tee & cross **GB**
 T-stuk & kruisstuk **NL**
 Tê & croix **F**

R=300mm

ET **3 4**

U10	U12	U15
3	3	3
4	4	4
Art. Nr.	Art. Nr.	Art. Nr.
U10T W 3	U12T W 3	U15T W 3
U10T W 4	U12T W 4	U15T W 4

R=300mm

X **3 4**

U10	U12	U15
3	3	3
4	4	4
Art. Nr.	Art. Nr.	Art. Nr.
U10X W 3	U12X W 3	U15X W 3
U10X W 4	U12X W 4	U15X W 4

CABLE LADDER

TYCEUELSUP 0311

CABLE LADDER

GB Outside riser 90° & 45°

NL Stijgstuk 90° & 45°

F Coude vertical exterieur 90° & 45°

D Fallstück 90° & 45°

N Utvendig riser 90° og 45°

S Utvändig vertikal vinkel 90° & 45°

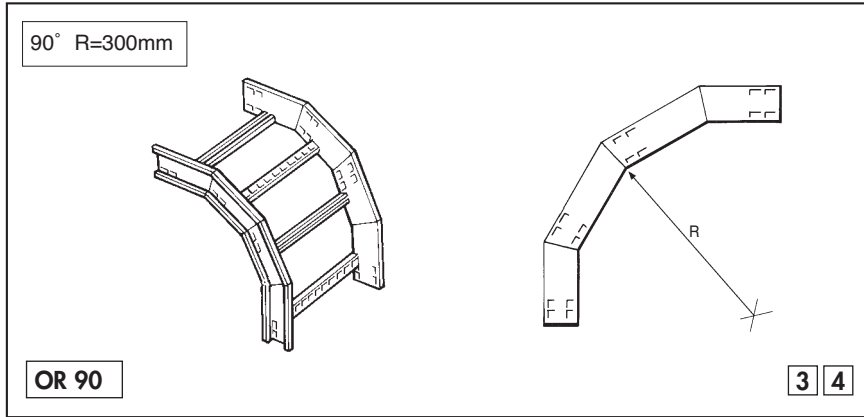

U10		U12		U15	
3	4	3	4	3	4
Art. Nr.	Art. Nr.	Art. Nr.	Art. Nr.	Art. Nr.	Art. Nr.
U10O W 3	U10O W 4	U12O W 3	U12O W 4	U15O W 3	U15O W 4

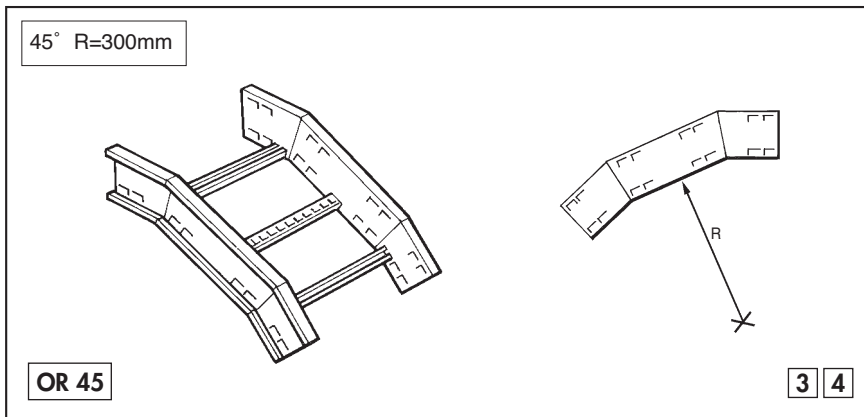

U10		U12		U15	
3	4	3	4	3	4
Art. Nr.	Art. Nr.	Art. Nr.	Art. Nr.	Art. Nr.	Art. Nr.
U10O W 453	U10O W 454	U12O W 453	U12O W 454	U15O W 453	U15O W 454

CABLE LADDER

Steigestück 90° & 45° **D**
 Innvendig riser 90° og 45° **N**
 Invändig vertikal vinkel **S**

Inside riser 90° & 45° **GB**
 Vervalstuk 90° & 45° **NL**
 Coude vertical interieur 90° & 45° **F**

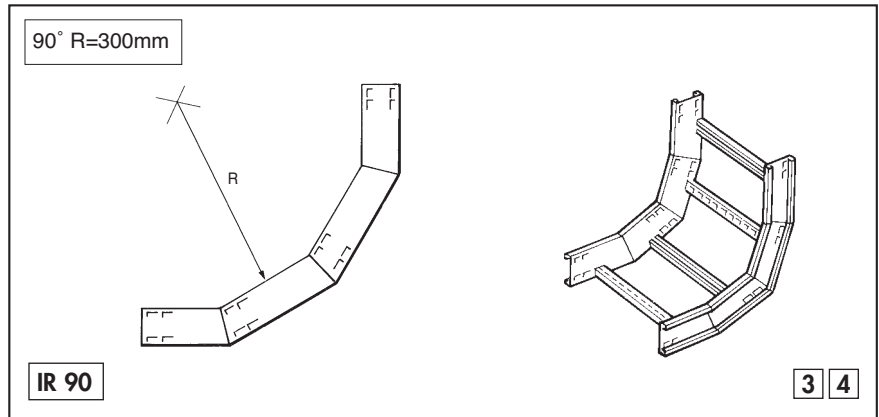

U10		U12		U15	
3	4	3	4	3	4
Art. Nr.	Art. Nr.	Art. Nr.	Art. Nr.	Art. Nr.	Art. Nr.
U10 W 3	U10 W 4	U12 W 3	U12 W 4	U15 W 3	U15 W 4

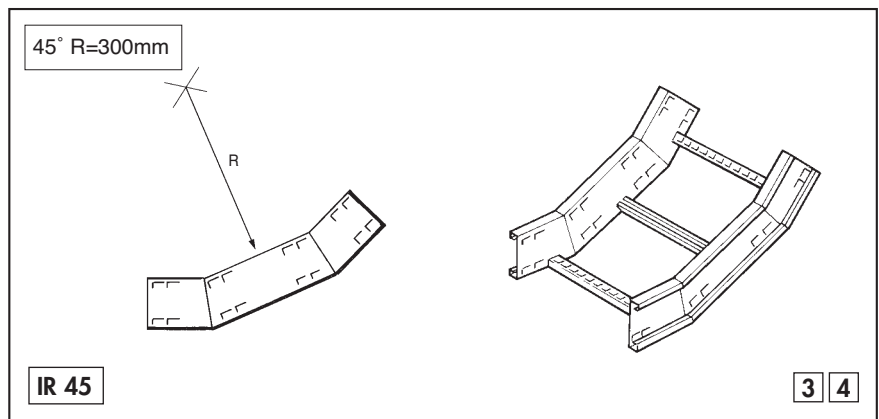

U10		U12		U15	
3	4	3	4	3	4
Art. Nr.	Art. Nr.	Art. Nr.	Art. Nr.	Art. Nr.	Art. Nr.
U10 W 453	U10 W 454	U12 W 453	U12 W 454	U15 W 453	U15 W 454

CABLE LADDER

CABLE LADDER

GB Couplers & accessories

NL Koppelplaten & hulpstukken

F Eclisses & accessoires

D Verbinder & Zubehör

N Skjøter og tilbehør

S Fästen & fästtillbehör

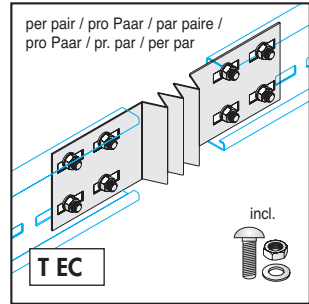
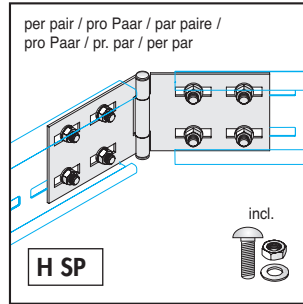
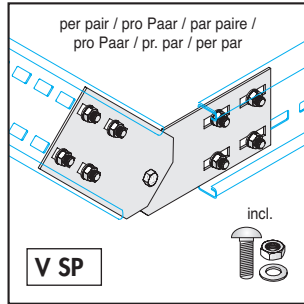
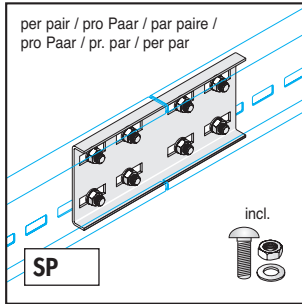

Type	3	4
	Art. Nr.	Art. Nr.
U10	U10SP3	U10SP4
U12	U12SP3	U12SP4
U15	U15SP3	U15SP4

Type	3	4
	Art. Nr.	Art. Nr.
U10	U10VSP3	U10VSP4
U12	U12VSP3	U12VSP4
U15	U15VSP3	U15VSP4

Type	3	4
	Art. Nr.	Art. Nr.
U10	U10HSP3	U10HSP4
U12	U12HSP3	U12HSP4
U15	U15HSP3	U15HSP4

Type	3	4
	Art. Nr.	Art. Nr.
U10	U10TEC3	U10TEC4
U12	U12TEC3	U12TEC4
U15	U15TEC3	U15TEC4

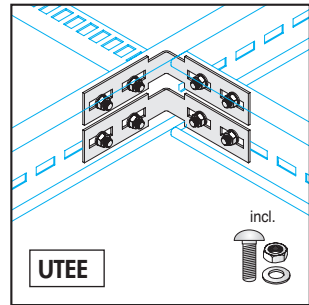
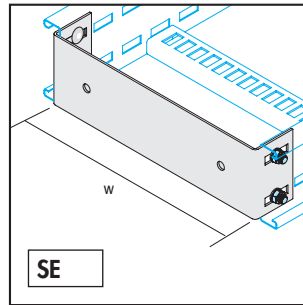
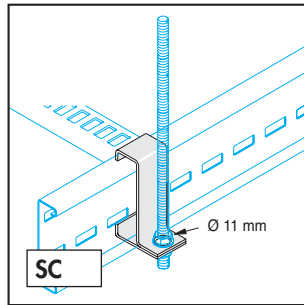
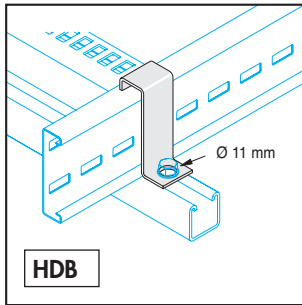

Type	3	4
	Art. Nr.	Art. Nr.
U10	U10HDB3	U10HDB4
U12	U12HDB3	U12HDB4
U15	U15HDB3	U15HDB4

Type	3	4
	Art. Nr.	Art. Nr.
U10	U10SC3	U10SC4
U12	U12SC3	U12SC4
U15	U15SC3	U15SC4

Type	3	4
	Art. Nr.	Art. Nr.
U10	U10SE W 3	U10SE W 4
U12	U12SE W 3	U12SE W 4
U15	U15SE W 3	U15SE W 4

Type	3	4
	Art. Nr.	Art. Nr.
U10	U10TEE3	U10TEE4
U12	U12TEE3	U12TEE4
U15	U15TEE3	U15TEE4

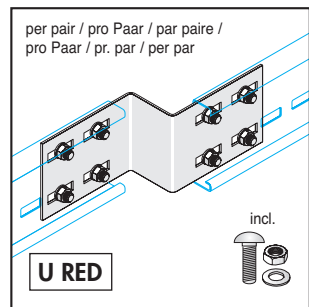
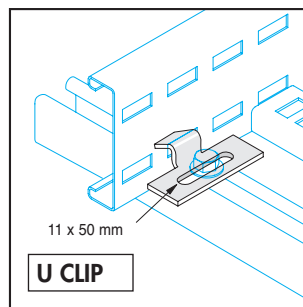
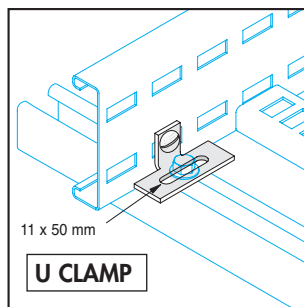
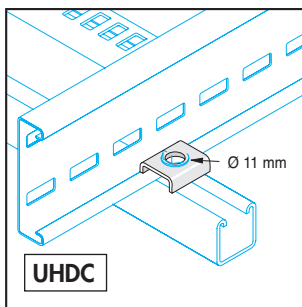

3	4
Art. Nr.	Art. Nr.
UHDC3	UHDC4

3	4
Art. Nr.	Art. Nr.
U CLAMP 3	U CLAMP 4

3	4
Art. Nr.	Art. Nr.
U CLIP 3	U CLIP 4

On request
Op aanvraag
Sur demande
Auf Anfrage
På forespørsel
På förfrågan

CABLE LADDER

Zubehör **D**
 Tilbehør **N**
 Tillbehör **S**

Accessories **GB**
 Accessoires **NL**
 Accessoires **F**

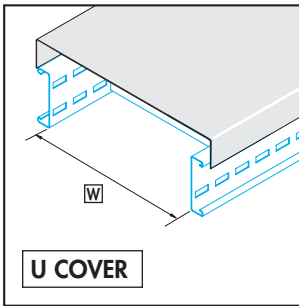

3	4
Art. Nr.	Art. Nr.
U/COV[W]3	U/COV[W]4

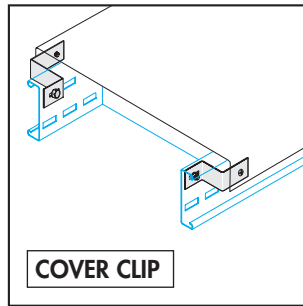

3	4
Art. Nr.	Art. Nr.
UCOVCLIP3	UCOVCLIP4

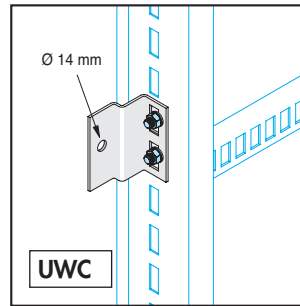

3	4
Art. Nr.	Art. Nr.
UWC 3	UWC 4

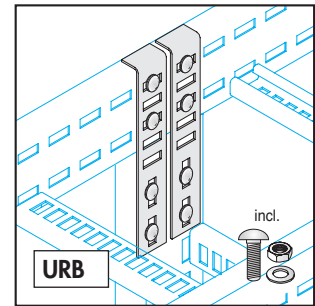

3	4
Art. Nr.	Art. Nr.
URB 3	URB 4

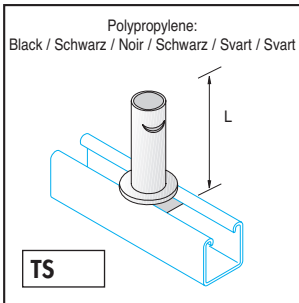

Art. Nr.	L (mm)
U TSS	75
U TSL	245

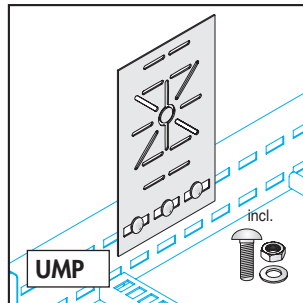

3	4
Art. Nr.	Art. Nr.
UMP3	UMP4

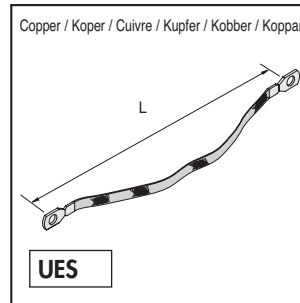

Art. Nr.	L (mm)
UES 100	100
UES 300	300

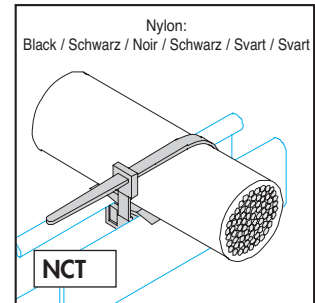

Art. Nr.
NCT75TB

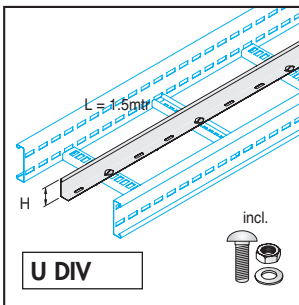

H (mm)	3	4
	Art. Nr.	Art. Nr.
30	UDIV303	UDIV304
70	UDIV703	UDIV704

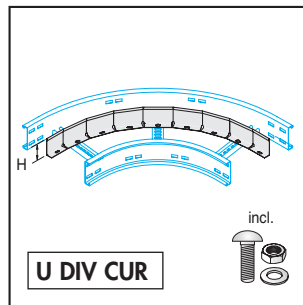

H (mm)	3	4
	Art. Nr.	Art. Nr.
30	UCUR303	UCUR304
70	UCUR703	UCUR704

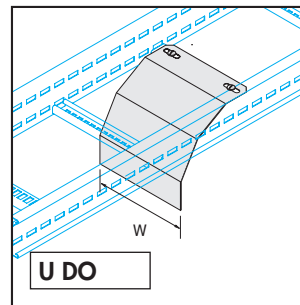

W (mm)	3	4
	Art. Nr.	Art. Nr.
145	UDO1503	UDO1504
195	UDO2003	UDO2004
295	UDO3003	UDO3004

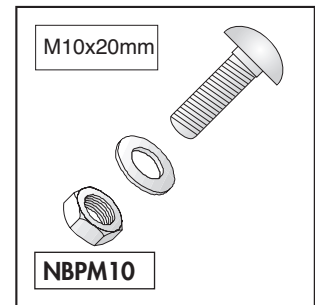

3	4	
Art. Nr.	Art. Nr.	
NBPM103	NBPM104	16

CABLE LADDER

CABLE LADDER

GB Load data

NL Belastinggegevens

F Charges admissibles

D Belastungswerte

N Belastungsdata

S Belastningsdata

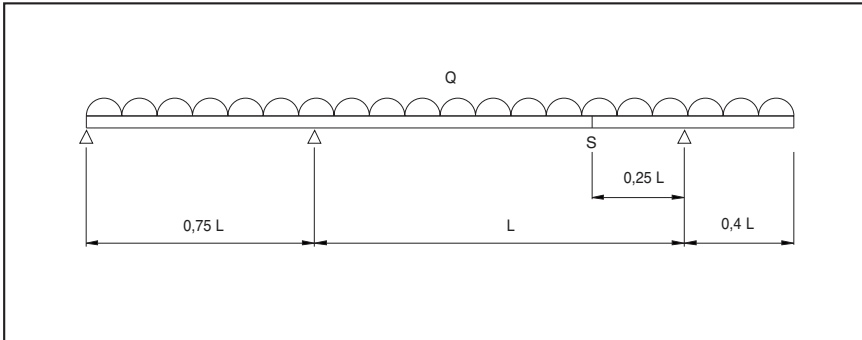

GB Load test according CEI/IEC 61537:2001

Q = UDL (uniformly distributed load)

Safety Factor = 1,7

L = intermediate span

F = deflection = 1/100 of the intermediate span (max.)

S = splice location

NL Belastingtest volgens CEI/IEC 61537:2001

Q = gelijkmatig verdeelde belasting

Veiligheidsfactor = 1,7

L = overspanning

F = doorbuiging = 1/100 van de overspanning (maximaal)

S = locatie van de koppelplaten

F Essai de charge suivant CEI/IEC 61537:2001

Q = CUR (charge uniformement repartie)

Coefficient de securité = 1,7

L = portée

F = flèche = 1/100 de la portée (max.)

S = position des éclisses

D Belastungsprüfung gemäß CEI/IEC 61537:2001

Q = Gleichlast

Sicherheitsbeiwert = 1,7

L = Stützabstand

F = Durchbiegung = 1/100 der Überspannung

S = Verbindungsstelle

N Testet i henhold til CEI/IEC 61537:2001

Q = jevnt fordelt last

Sikkerhetsfaktor 1,7

L = Avstand mellom oppheng

F = nedbøyning = 1/100 av opphengsavstand

S = plassering av skjot

S Belastnings test CEI/EIC 61537:2001

Q = Likformigt fördelad last med en

Säkerhetsfaktor av 1.7

L = Avstånd mellan fästpunkterna

F = Nedböjning= 1/100 av avståndet mellan fästpunkterna

S = skarvpunkt

CABLE LADDER

Belastungsdiagramme **D**

Belastingsdata **N**

Belastingsdata **S**

Load data **GB**

Belastingsgegevens **NL**

Charges admissibles **F**

Width/ Breedte/ Largeur Breite Bredde Breidd (mm)	Useful cross section / Maximale capaciteit Capacité théorique maximale / Nutzquerschnitt / Nyttbart tverrsnitt / Maximal belastning (cm ²)
100	75
150	113
200	150
300	225
400	300
450	338
500	3750
600	450
750	563
800	600
900	675
1000	750

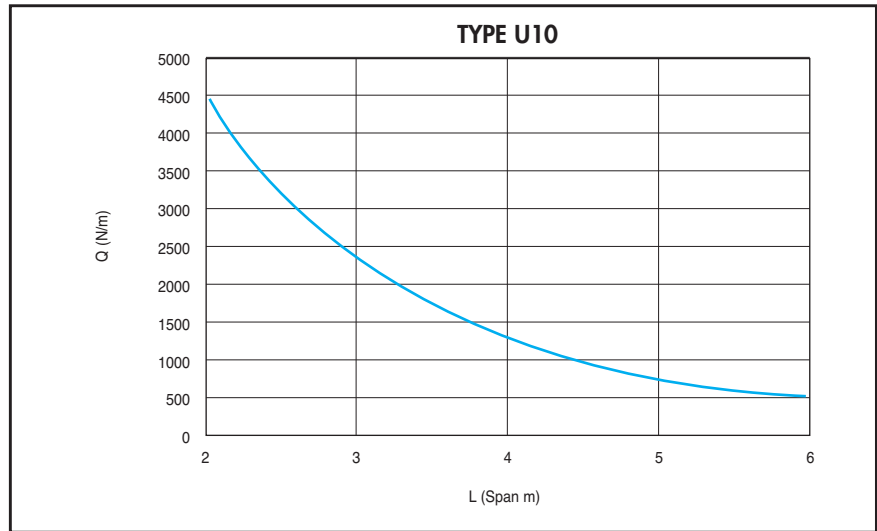

Width/ Breedte/ Largeur Breite Bredde Breidd (mm)	Useful cross section / Maximale capaciteit Capacité théorique maximale / Nutzquerschnitt / Nyttbart tverrsnitt / Maximal belastning (cm ²)
100	100
150	150
200	200
300	300
400	400
450	450
500	500
600	600
750	750
800	800
900	900
1000	1000

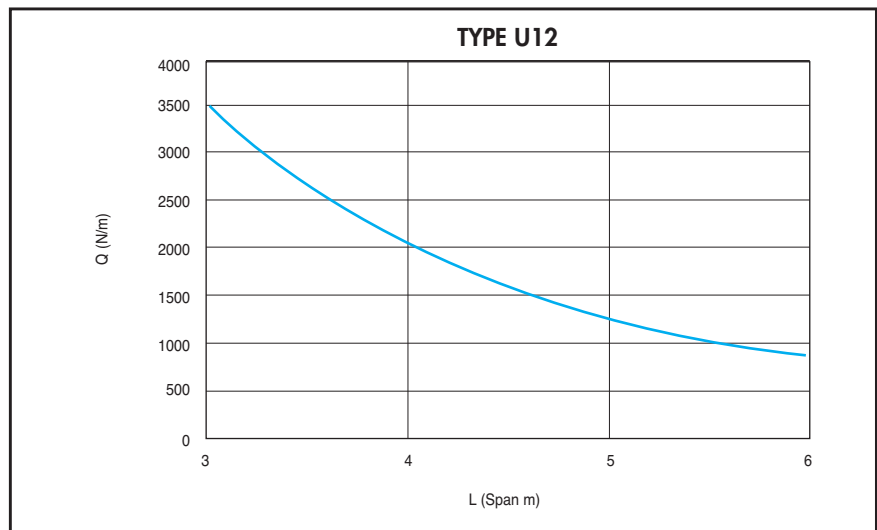

Width/ Breedte/ Largeur Breite Bredde Breidd (mm)	Useful cross section / Maximale capaciteit Capacité théorique maximale / Nutzquerschnitt / Nyttbart tverrsnitt / Maximal belastning (cm ²)
100	125
150	188
200	250
300	375
400	500
450	563
500	625
600	750
750	938
800	1000
900	1125
1000	1250

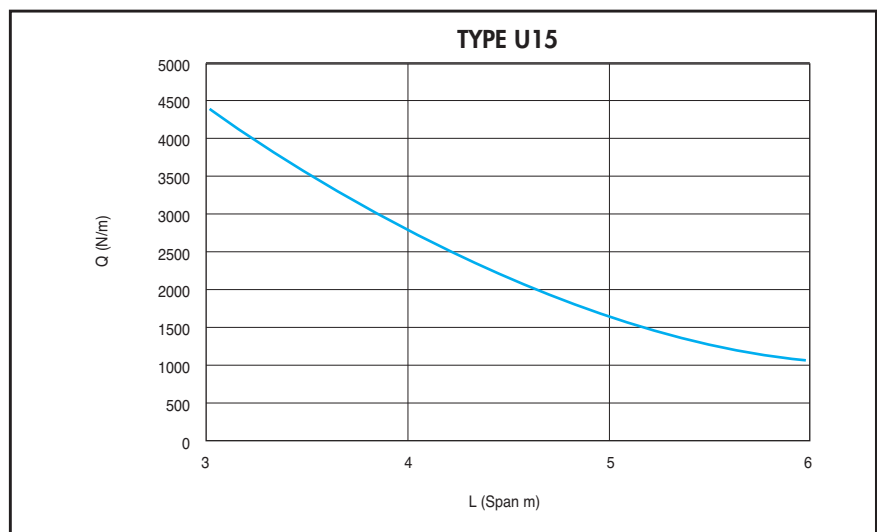

CABLE LADDER

TYCEUELSUP 0311

MARINE LADDER

- GB** Marine Ladder
- NL** Scheepsladderbaan
- F** Echelles marine

- D** Kabelleitern nach Marinenorm
- N** Skipsstige
- S** Stegar för marint bruk

Dimensions
Afmetingen
Dimensions
Abmessungen
Dimensioner

standard on request / op aanvraag / sur demande / auf Anfrage / På forespørsel / På förfrågan

Side rail / zijwand / longerons / Leitertragprofil / Sidevanger / Sidoväggar

Rungs / Sporten / Echelons / Sprossen / Trinn / Steg pinnar

Type V Type Z

57/36 H= 17 mm 10/26/23/26/10 H= 23 mm

40 & 50 mm 30x11 mm

- GB** Welded
- NL** Gelast
- F** Soudure
- D** Verschweiß
- N** Sveiset
- S** Svetsas

L = 3 m

USL **3 4 7**

USLB **3 4 7**

USLE **3 4 7**

Art. Nr.	W mm	kg /m
USL P 075	75	2,8
USL P 100	100	2,9
USL P 150	150	3,1
USL P 200	200	3,3
USL P 250	250	3,6
USL P 300	300	3,8
USL P 400	400	4,3
USL P 500	500	4,8

Art. Nr.	W mm	R mm	kg
USLB P 075	75	100	1,6
USLB P 100	100	100	1,7
USLB P 150	150	100	2,0
USLB P 200	200	100	2,2
USLB P 250	250	100	2,8
USLB P 300	300	150	3,7
USLB P 400	400	150	4,5
USLB P 500	500	200	6,1

Art. Nr.	W mm	R mm	kg
USLE P 075	75	100	1,4
USLE P 100	100	100	1,5
USLE P 150	150	100	1,7
USLE P 200	200	100	1,8
USLE P 250	250	100	2,0
USLE P 300	300	150	2,5
USLE P 400	400	150	2,8
USLE P 500	500	200	3,4

USLT **3 4 7**

USLR **3 4 7**

Art. Nr.	W mm	R mm	kg
USLT P 075	75	100	2,5
USLT P 100	100	100	2,7
USLT P 150	150	100	3,2
USLT P 200	200	100	3,6
USLT P 250	250	100	4,1
USLT P 300	300	150	5,4
USLT P 400	400	150	6,5
USLT P 500	500	200	8,8

Art. Nr.	W mm	R mm	kg
USLR P 075	75	150	1,9
USLR P 100	100	150	2,0
USLR P 150	150	150	2,2
USLR P 200	200	150	2,5
USLR P 250	250	150	2,8
USLR P 300	300	150	3,0
USLR P 400	400	150	3,5
USLR P 500	500	150	4,0

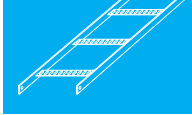

MARINE LADDER

Kabelleitern nach Marinenorm **D**
 Skipsstige **N**
 Stegar för marint bruk **S**

Marine Ladder **GB**
 Scheepsladderbaan **NL**
 Echelles marine **F**

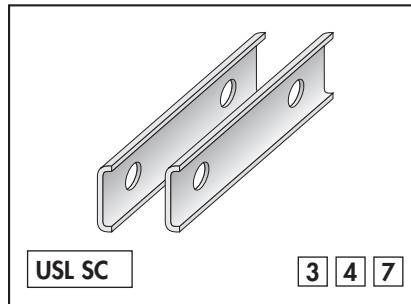

Art. Nr.	/100	
USLSC P	10,0	100

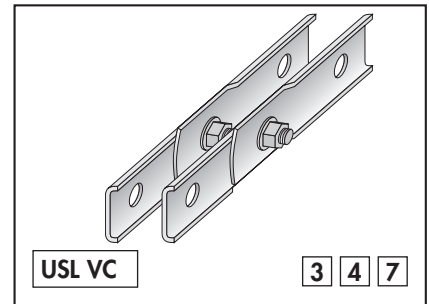

Art. Nr.	/100	
USLVC P	30,0	100

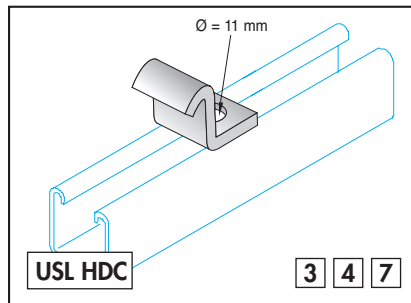

Art. Nr.	/100	
USLHDC P	9,0	100

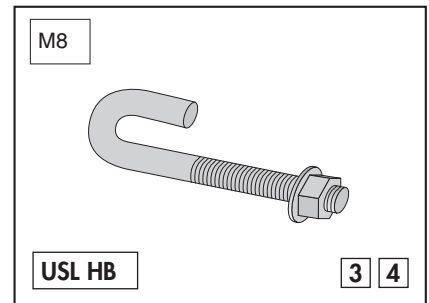

Art. Nr.	/100	
USLHB P	5,0	100

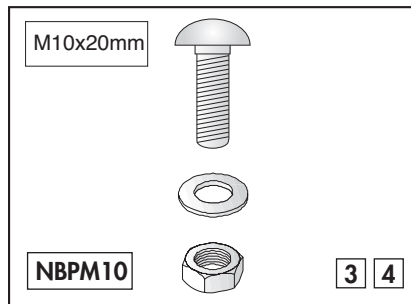

Art. Nr.	/100	
NBPM10 P	3,4	16

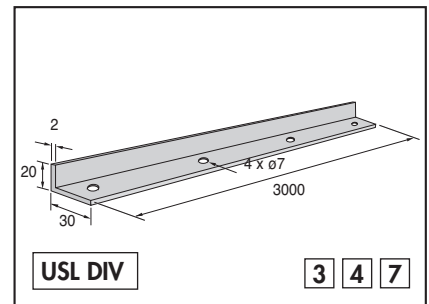

Art. Nr.	/100	
USL DIV P	0,8	100

MARINE LADDER

MARINE LADDER

GB Load data

NL Belastinggegevens

F Charges admissibles

D Belastungswerte

N Belastungsdata

S Belastungsdata

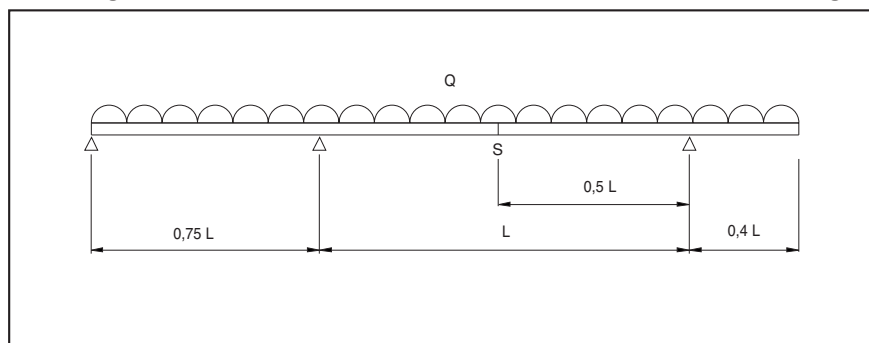

GB Load test according CEI/IEC 61537:2001

Q = UDL (uniformly distributed load)

Safety Factor = 1,7

L = intermediate span

F = deflection = 1/100 of the intermediate span (max.)

S = splice location

NL Belastingtest volgens CEI/IEC 61537:2001

Q = gelijkmatig verdeelde belasting

Veiligheidsfactor = 1,7

L = overspanning

F = doorbuiging = 1/100 van de overspanning (maximaal)

S = locatie van de koppelplaten

F Essai de charge suivant CEI/IEC 61537:2001

Q = CUR (charge uniformement répartie)

Coefficient de sécurité = 1,7

L = portée

F = flèche = 1/100 de la portée (max.)

S = position des éclisses

D Belastungsprüfung gemäß CEI/IEC 61537:2001

Q = Gleichlast

Sicherheitsbeiwert = 1,7

L = Stützabstand

F = Durchbiegung = 1/100 der Überspannung

S = Verbindungsstelle

N Testet i henhold til CEI/IEC 61537:2001

Q = jevnt fordelt last

Sikkerhetsfaktor 1,7

L = Avstand mellom oppheng

F = nedbøyning = 1/100 av opphengsavstand

S = plassering av skjot

S Belastningstest CEI/IEC 61537:2001

Q = likformigt fördelad belastning med en säkerhetsfaktor av 1.7

L = Avstånd mellan fästpunkter

F = Nedböjning=1/100 av avståndet mellan fästpunkterna

S = Skarpunkt



MARINE LADDER

Belastungsdiagramm **D**

Belastingsdata **N**

Belastningsdata **S**

Load data **GB**

Belastingsgegevens **NL**

Charges admissibles **F**

Width/ Breedte/ Largeur Breite Bredd Bredd (mm)	Useful cross section / Maximale capaciteit Capacité théorique maximale / Nutzquerschnitt / Nyttbart tverrsnitt / Maximal belastning (cm ²)
75	9,75
100	13,0
150	19,5
200	26,0
250	32,5
300	39,0
400	52,0
500	65,0

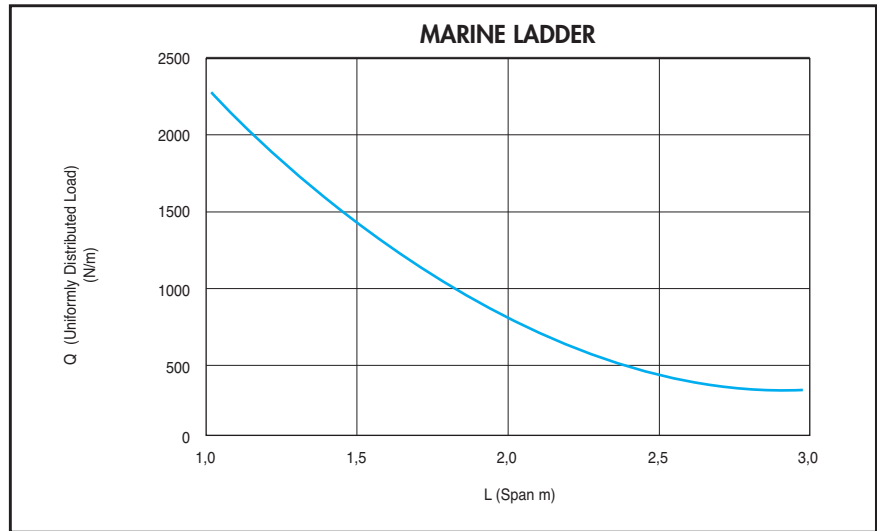

TUBE SYSTEM

- GB** Tube system
- NL** Kabelbuissysteem
- F** Tube à câbles

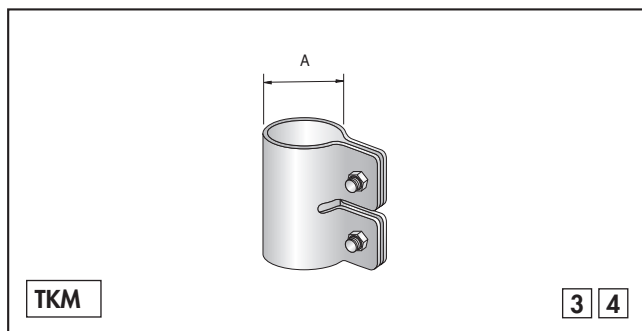
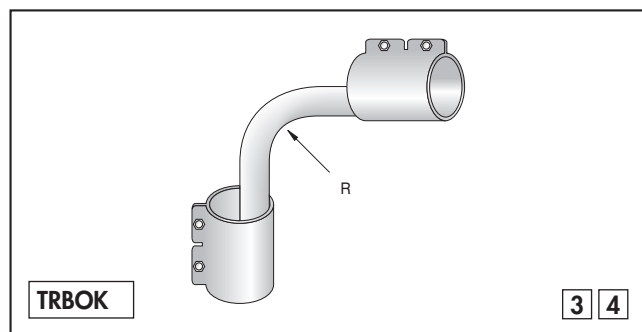
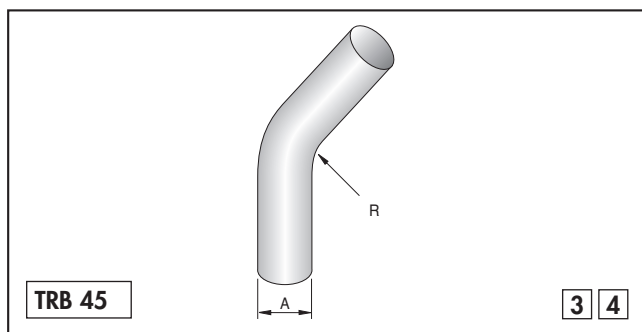
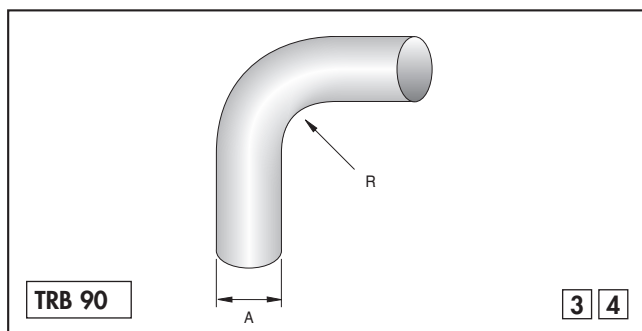
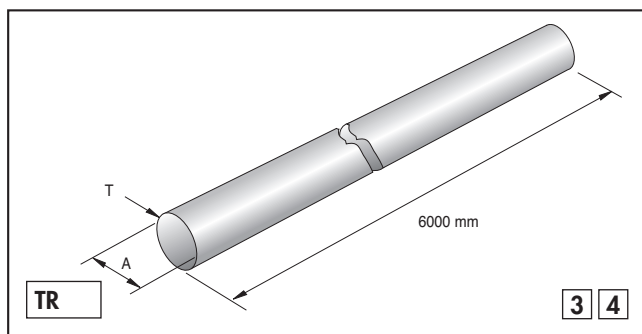

- D** Leitungsschutzrohrsystem
- N** Rørsystem
- S** Tub system

Art. Nr.	A mm	T mm	P	⚖️
B3R30	30	1,5	3	7,0
B3R60	60	1,5	3	17,1
B7R30	30	1,5	4	7,0
B7R60	60	2,0	4	17,1

Art. Nr.	A mm	R mm	P	⚖️
B3RB9030	30	80	3	0,72
B3RB9060	60	90	3	1,35
B7RB9030	30	80	4	0,72
B7RB9060	60	90	4	1,35

Art. Nr.	A mm	R mm	P	⚖️
B3RB4530	30	80	3	0,56
B3RB4560	60	90	3	1,05
B7RB4530	30	80	4	0,56
B7RB4560	60	90	4	1,05

Art. Nr.	A mm	R mm	P	⚖️
B3RBOK9030	30	120	3	1,8
B3RBOK9060	60	150	3	1,9
B7RBOK9030	30	120	4	1,8
B7RBOK9060	60	150	4	1,9

Art. Nr.	A mm	P	⚖️
B3KM30	30	3	0,20
B3KM60	60	3	0,47
B7KM30	30	4	0,20
B7KM60	60	4	0,47

TUBE SYSTEM

TYCEUELSUP 0311



TUBE SYSTEM

Leitungsschutzrohrsystem **D**
 Rørssystem **N**
 Tub system **S**

Tube system **GB**
 Kabelbuissysteem **NL**
 Tube à câbles **F**

Art. Nr.	A mm	P	⚖
B3LM30	30	3	0,30
B3LM60	60	3	0,90
B7LM30	30	4	0,30
B7LM60	60	4	0,90

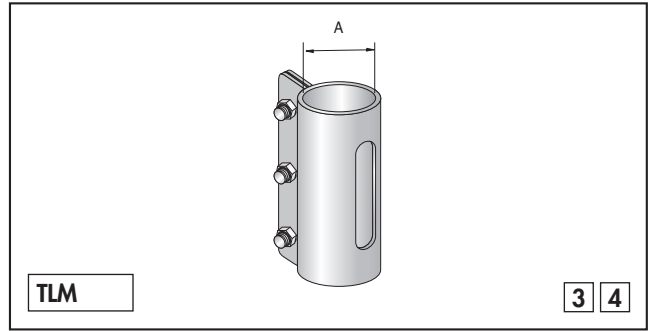

Art. Nr.	A mm	P	⚖
B3FB30	30	3	0,71
B3FB60	60	3	1,75
B7FB30	30	4	0,71
B7FB60	60	4	1,75

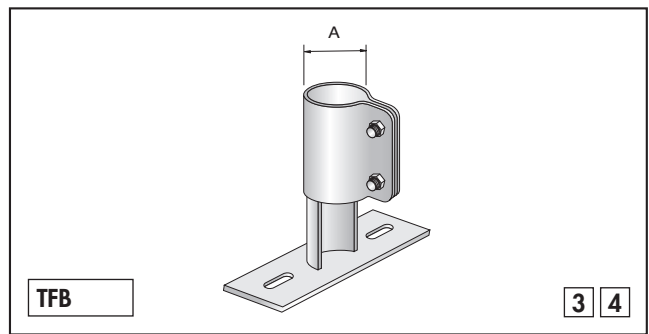

Art. Nr.	A mm	P	⚖
B3MI30	30	3	0,45
B3MI60	60	3	0,50
B7MI30	30	4	0,45
B7MI60	60	4	0,50

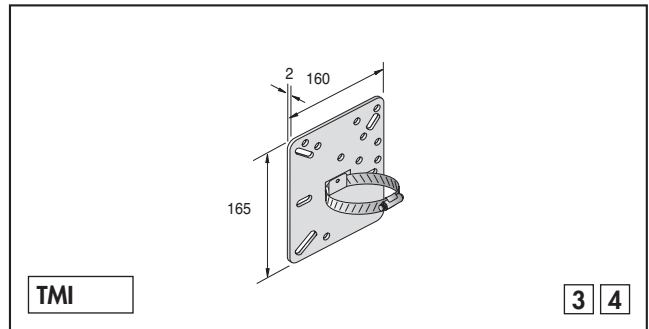

Art. Nr.	A mm	P	⚖
B3MII30	30	3	0,80
B3MII60	60	3	0,85
B7MII30	30	4	0,80
B7MII60	60	4	0,85

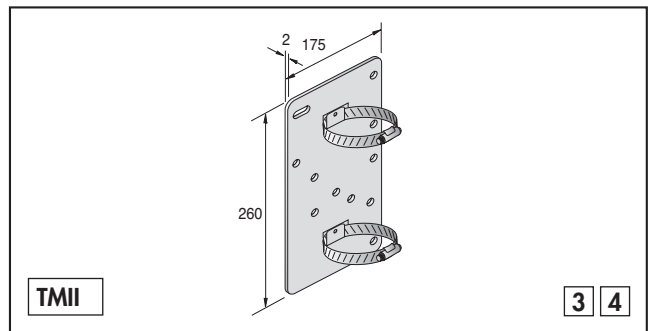

Art. Nr.	A mm	P	⚖
B3MIII30	30	3	1,75
B3MIII60	60	3	1,80
B7MIII30	30	4	1,75
B7MIII60	60	4	1,80

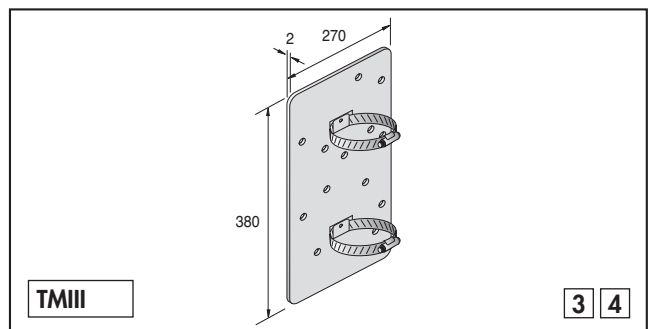

TUBE SYSTEM

TYCEUELSUP 0311

TUBE SYSTEM

- GB** Tube system
- NL** Kabelbuissysteem
- F** Tube à câbles

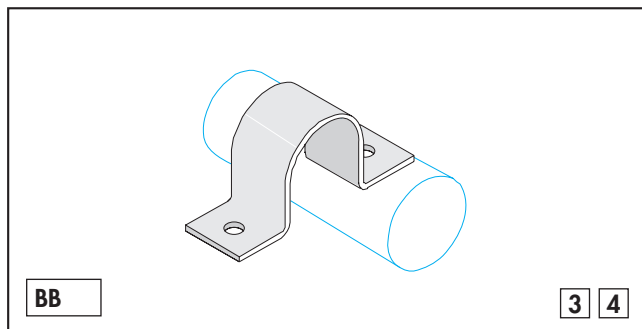
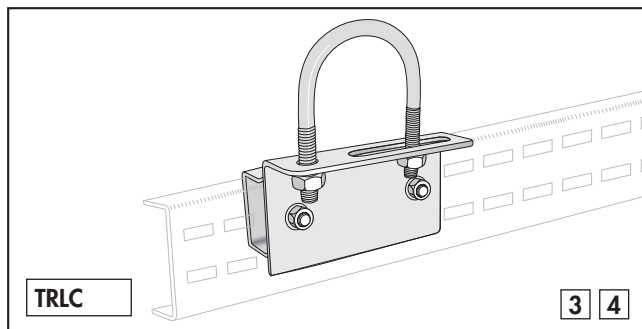
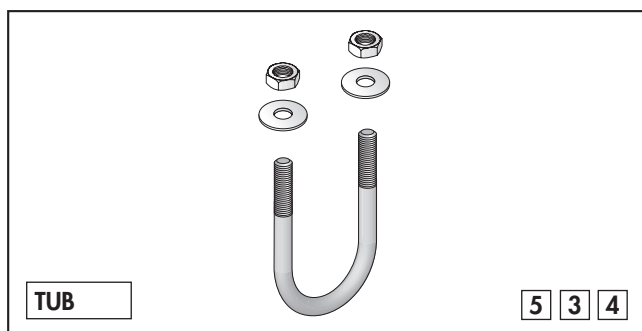
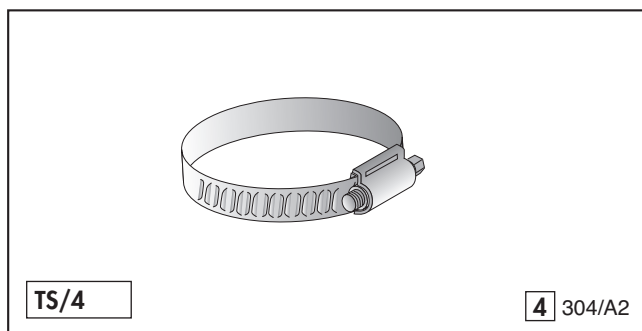

- D** Leitungsschutzrohrsystem
- N** Rørsystem
- S** Tub system

Art. Nr.	A mm	P	
B4S1430	30	4	0,03
B4S1460	60	4	0,04

Art. Nr.	A mm	P	
TUB330	30	3	0,07
TUB360	60	3	0,10
TUB730	30	4	0,07
TUB760	60	4	0,10

Art. Nr.	A mm	P	
B3LC30	30	3	0,58
B3LC60	60	3	0,72
B7LC30	30	4	0,58
B7LC60	60	4	0,72

Art. Nr.	Ø mm	P	
BB330	30	3	0,1
BB360	60	3	0,15
BB730	30	4	0,1
BB760	60	4	0,15



TUBE SYSTEM

Leitungsschutzrohrsystem **D**

Rørsystem **N**

Tub system **S**

Tube system **GB**

Leitungsschutzrohrsystem **NL**

Tube à câbles **F**

Art. Nr.	A mm	
B/EO30PE	30	0,010
B/EO60PE	60	0,020

Art. Nr.	
B/K/PVC	1 M

PVC yellow/geel/jaune/gelb/gul/gul

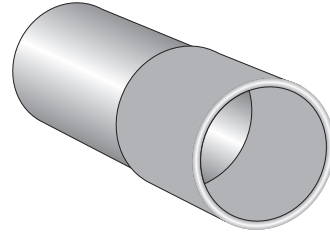

TEO

PVC black/zwart/noir/schwarz/svart/svart

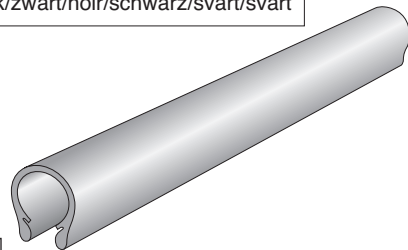

TK PVC

UNISTRUT T4000 & T3100

T4000

Y
Z
X
Z
Y

1.5

$A = 1.30 \text{ cm}^2$
 $\rho/m = 1.16 \text{ kg/m}$
 $I_{y-y} = 0.75 \text{ cm}^4$
 $I_{z-z} = 0.70 \text{ cm}^4$
 $r_{y-y} = 0.76 \text{ cm}$
 $r_{z-z} = 0.76 \text{ cm}$
 $I_{z-z} = 3.64 \text{ cm}^4$
 $r_{z-z} = 1.67 \text{ cm}$

2

L(mm)	$\sigma=175 \text{ N/mm}^2$		$\sigma=175 \text{ N/mm}^2$		$f=1/200L$ F (kN)	$f=1/360L$ F (kN)	F(kN)
	Fmax(kN)	fmax(mm)	Fmax(kN)	fmax(mm)			
250	1.957	0.41	3.914	0.51	-	-	-
500	0.976	1.66	1.952	2.07	-	1.305	-
750	0.652	3.73	1.305	4.66	1.040	0.579	-
1000	0.486	6.63	0.971	8.29	0.589	0.324	-
1250	0.387	10.37	0.775	12.96	0.373	0.206	-
1500	0.324	14.94	0.647	18.67	0.255	-	-
1750	0.280	20.33	0.559	25.41	-	-	-
2000	0.240	26.55	0.481	33.19	-	-	-

Art.Nr.	P	L (m)
P4011322	2	2
P4011323	2	3
P4011326	2	6

T3100

Y
Z
X
Z
Y

2.0

$A = 1.74 \text{ cm}^2$
 $\rho/m = 1.47 \text{ kg/m}$
 $I_{y-y} = 0.96 \text{ cm}^4$
 $I_{z-z} = 0.88 \text{ cm}^4$
 $r_{y-y} = 0.74 \text{ cm}$
 $r_{z-z} = 2.24 \text{ cm}$
 $I_{z-z} = 4.63 \text{ cm}^4$
 $r_{z-z} = 1.63 \text{ cm}$

2

L(mm)	$\sigma=175 \text{ N/mm}^2$		$\sigma=175 \text{ N/mm}^2$		$f=1/200L$ F (kN)	$f=1/360L$ F (kN)	F(kN)
	Fmax(kN)	fmax(mm)	Fmax(kN)	fmax(mm)			
250	2.295	0.39	4.983	0.50	-	-	-
500	1.145	1.55	2.492	2.01	-	1.707	-
750	0.760	3.49	1.658	4.54	1.364	0.755	-
1000	0.567	6.20	1.246	8.07	0.765	0.422	-
1250	0.450	9.69	0.991	12.61	0.491	0.265	-
1500	0.372	13.99	0.824	18.17	0.334	-	-
1750	0.316	19.10	0.706	24.73	0.245	-	-
2000	0.275	25.10	0.618	32.30	-	-	-

Art.Nr.	P	L (mm)
P3111322	2	2
P3111323	2	3
P3111326	2	6

*k.L/r =>180 < 250

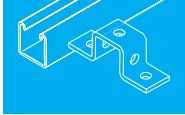

UNISTRUT P3300

2.5

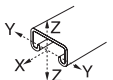

$A = 1.97 \text{ cm}^2$
 $\rho/m = 1.76 \text{ kg/m}$
 $I_{y-y} = 0.98 \text{ cm}^4$
 $Z_{y-y} = 0.89 \text{ cm}^3$
 $r_{y-y} = 0.70 \text{ cm}$
 $I_{z-z} = 5.29 \text{ cm}^4$
 $Z_{z-z} = 2.56 \text{ cm}^3$
 $r_{z-z} = 1.63 \text{ cm}$

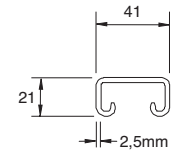

41
21
-2,5mm

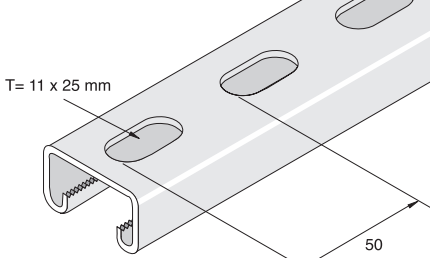

T= 11 x 25 mm
50

2
3
3
4
4 304/A2

P3300T

L(mm)	$\sigma=175 \text{ N/mm}^2$		$\sigma=175 \text{ N/mm}^2$		$f=1/200L$	$f=1/360L$	F(kN)
	Fmax(kN)	fmax(mm)	Fmax(kN)	fmax(mm)	F (kN)	F (kN)	
250	2.492	0.40	4.983	0.50	-	-	-
500	1.246	1.61	2.492	2.01	-	1.707	-
750	0.829	3.63	1.658	4.54	1.364	0.755	-
1000	0.623	6.46	1.246	8.07	0.765	0.422	-
1250	0.495	10.09	0.991	12.61	0.491	0.265	-
1500	0.412	14.54	0.824	18.17	0.334	-	-
1750	0.353	19.78	0.706	24.73	0.245	-	-
2000	0.309	25.84	0.618	32.30	-	-	-

Art.Nr.	P	L (m)
P3311322	2	2
P3311323	2	3
P3311326	2	6
P3311333	3	3
P3311336	3	6
P3311346	4	6
P3311396	4 304/A2	6

2.5

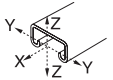

$A = 2.32 \text{ cm}^2$
 $\rho/m = 1.91 \text{ kg/m}$
 $I_{y-y} = 1.19 \text{ cm}^4$
 $Z_{y-y} = 0.97 \text{ cm}^3$
 $r_{y-y} = 0.71 \text{ cm}$
 $I_{z-z} = 5.34 \text{ cm}^4$
 $Z_{z-z} = 2.59 \text{ cm}^3$
 $r_{z-z} = 1.51 \text{ cm}$

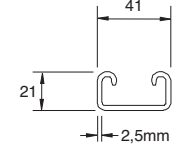

41
21
-2,5mm

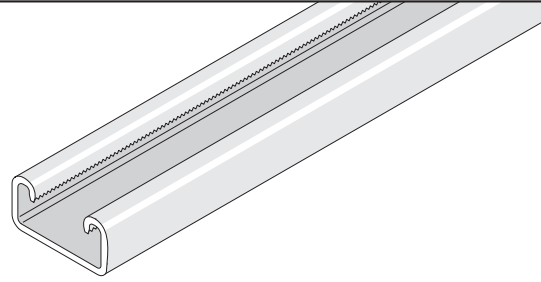

1
2
3
4

P3300

L(mm)	$\sigma=175 \text{ N/mm}^2$		$\sigma=175 \text{ N/mm}^2$		$f=1/200L$	$f=1/360L$	F(kN)
	Fmax(kN)	fmax(mm)	Fmax(kN)	fmax(mm)	F (kN)	F (kN)	
250	2.712	0.36	5.425	0.45	-	-	10.222
500	1.354	1.45	2.708	1.81	-	2.080	9.761
750	0.903	3.26	1.805	4.07	1.658	0.922	8.427
1000	0.677	5.79	1.354	7.24	0.932	0.520	6.769
1250	0.540	9.06	1.079	11.32	0.598	0.324	5.376
1500	0.451	13.04	0.903	16.30	0.412	0.226	4.287*
1750	0.387	17.75	0.775	22.19	0.304	-	3.463*
2000	0.338	23.19	0.677	28.99	0.226	-	-

Art.Nr.	P	L (m)
P3311116	1	6
P3311126	2	6
P3311136	3	6
P3311146	4	6

*k.L/r =>180 < 250

SUPPORT SYSTEMS

TYCEUCLUP 0311

UNISTRUT T2000 & T1100

T= 14 x 28 mm

50

41

41

1,5mm

1.5

Y
Z
X

A = 1.92 cm²
 ρ/m = 1.72 kg/m
 I_{y-y} = 4.24 cm⁴
 Z_{y-y} = 2.04 cm³
 r_{y-y} = 1.48 cm
 I_{z-z} = 6.10 cm⁴
 Z_{z-z} = 2.95 cm³
 r_{z-z} = 1.78 cm

T2000T

2

L(mm)	F α=160 N/mm ²		F α=160 N/mm ² f=1/200L		f=1/360L		F(kN)
	Fmax(kN)	fmax(mm)	Fmax(kN)	fmax(mm)	F (kN)	F (kN)	
250	5.221	0.19	10.441	0.24	-	-	11.350
500	2.615	0.77	5.230	0.96	-	-	11.183
750	1.737	1.73	3.474	2.16	-	-	10.654
1000	1.298	3.07	2.597	3.84	-	1.165	9.310
1250	1.033	4.77	2.066	5.96	-	0.748	7.799
1500	0.865	6.94	1.730	8.68	-	0.51	6.543
1750	0.735	9.42	1.470	11.78	0.68	0.371	5.552
2000	0.640	12.31	1.280	15.39	0.515	0.277	4.787
2250	0.565	15.62	1.130	19.53	0.4	0.213	4.179
2500	0.503	19.24	1.006	24.05	0.316	0.166	3.698
2750	0.455	23.40	0.911	29.25	0.256	0.131	3.306*
3000	0.414	27.94	0.828	34.93	0.208	0.103	2.992*

Art.Nr.	P	L (m)
P2011223	2	3
P2011226	2	6

*k.L/r =>180 < 250

14 x 30 mm

50

41

41

2,0mm

2.0

Y
Z
X

A = 2.51 cm²
 ρ/m = 2.18 kg/m
 I_{y-y} = 5.33 cm⁴
 Z_{y-y} = 2.58 cm³
 r_{y-y} = 1.42 cm
 I_{z-z} = 9.17 cm⁴
 Z_{z-z} = 4.44 cm³
 r_{z-z} = 1.74 cm

T1100T

2 3

L(mm)	F α=160 N/mm ²		F α=160 N/mm ²		f=1/200L	f=1/360L
	Fmax(kN)	fmax(mm)	Fmax(kN)	fmax(mm)	F (kN)	F (kN)
250	6.605	0.19	13.210	0.24	-	-
500	3.302	0.77	6.604	0.96	-	-
750	2.202	1.73	4.404	2.17	-	-
1000	1.651	3.07	3.302	3.86	-	1.492
1250	1.321	4.80	2.642	6.10	-	0.955
1500	1.101	6.92	2.202	8.80	-	0.663
1750	0.944	9.41	1.888	12.00	0.877	0.487
2000	0.826	12.29	1.652	15.73	0.672	0.373
2250	0.734	15.56	1.468	20.00	0.531	0.295
2500	0.660	19.21	1.320	24.90	0.430	0.239
2750	0.600	23.24	1.200	30.30	0.355	0.197
3000	0.550	27.66	1.100	36.40	0.298	0.166

Art.Nr.	P	L (m)
P1111222	2	2
P1111223	2	3
P1111226	2	6
P1111236	3	6

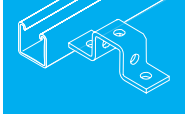

UNISTRUT P1000

2.5

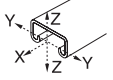

$A = 3.00 \text{ cm}^2$
 $\rho/m = 2.73 \text{ kg/m}$
 $I_{y-y} = 6.10 \text{ cm}^4$
 $Z_{y-y} = 2.87 \text{ cm}^3$
 $r_{y-y} = 1.42 \text{ cm}$
 $I_{z-z} = 9.17 \text{ cm}^4$
 $Z_{z-z} = 4.44 \text{ cm}^3$
 $r_{z-z} = 1.74 \text{ cm}$

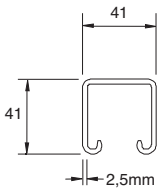

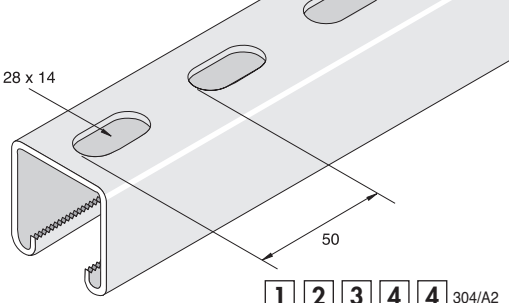

28 x 14

50

1 2 3 4 4 304/A2

P1000T

L(mm)	$\sigma=175 \text{ N/mm}^2$		$\sigma=175 \text{ N/mm}^2$		$f=1/200L$	$f=1/360L$	F(kN)
	Fmax(kN)	fmax(mm)	Fmax(kN)	fmax(mm)	F(kN)	F(kN)	
250	8.034	0.22	16.069	0.27	-	-	16.283
500	4.017	0.84	8.034	1.05	-	-	16.039
750	2.678	1.88	5.356	2.35	-	4.738	15.274
1000	2.006	3.34	4.012	4.18	-	2.659	13.626
1250	1.604	5.23	3.208	6.54	3.071	1.707	11.880
1500	1.339	7.93	2.678	9.41	2.129	1.177	10.418
1750	1.148	10.25	2.296	12.81	1.560	0.863	9.231
2000	1.001	13.38	2.001	16.73	1.197	0.657	8.270
2250	0.893	16.94	1.785	21.18	0.942	0.520	7.465
2500	0.800	20.92	1.599	26.15	0.765	0.422	6.779
2750	0.726	25.31	1.452	31.64	0.628	0.343	6.190*
3000	0.667	30.12	1.334	37.65	0.530	0.294	5.670*

Art.Nr.	P	L (m)
P1011216	1	6
P1011222	2	2
P1011223	2	3
P1011226	2	6
P1011233	3	3
P1011236	3	6
P1011243	4	3
P1011246	4	6
P1011293	4 (304/A2)	3
P1011296	4 (304/A2)	6

*k.L/r =>180 < 250

2.5

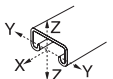

$A = 3.35 \text{ cm}^2$
 $\rho/m = 2.88 \text{ kg/m}$
 $I_{y-y} = 7.21 \text{ cm}^4$
 $Z_{y-y} = 3.10 \text{ cm}^3$
 $r_{y-y} = 1.46 \text{ cm}$
 $I_{z-z} = 9.23 \text{ cm}^4$
 $Z_{z-z} = 4.47 \text{ cm}^3$
 $r_{z-z} = 1.66 \text{ cm}$

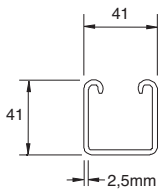

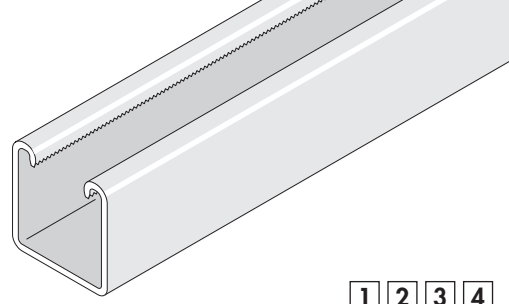

1 2 3 4

P1000

L(mm)	$\sigma=175 \text{ N/mm}^2$		$\sigma=175 \text{ N/mm}^2$		$f=1/200L$	$f=1/360L$	F(kN)
	Fmax(kN)	fmax(mm)	Fmax(kN)	fmax(mm)	F(kN)	F(kN)	
250	8.677	0.18	17.354	0.23	-	-	16.608
500	4.336	0.76	8.672	0.95	-	-	16.187
750	2.889	1.72	5.778	2.15	-	5.602	15.245
1000	2.168	3.06	4.336	3.82	-	3.149	13.685
1250	1.731	4.78	3.463	5.97	-	2.011	12.086
1500	1.442	6.88	2.884	8.60	2.521	1.393	10.722
1750	1.236	9.36	2.472	11.70	1.844	1.020	9.575
2000	1.084	12.23	2.168	15.29	1.413	0.785	8.623
2250	0.961	15.48	1.923	19.35	1.118	0.618	7.819
2500	0.863	19.11	1.727	23.89	0.903	0.500	7.112
2750	0.785	23.13	1.570	28.91	0.746	0.412	6.504*
3000	0.721	27.52	1.442	34.40	0.628	0.343	5.955*

*k.L/r =>180 < 250

SUPPORT SYSTEMS

TYCEUCLUSUP 0311

UNISTRUT P5500 & P5000

P5500T

T= 14 x 28 mm

41

62

2,5mm

2.5

Y
X
Z

A = 4.03 cm²
 ρ/m = 3.60 kg/m
 I y-y = 17.67 cm⁴
 Z y-y = 5.59 cm³
 r y-y = 2.09 cm
 I z-z = 13.07 cm⁴
 Z z-z = 6.33 cm³
 r z-z = 1.79 cm

2 3

L(mm)	σ=167 N/mm ²		σ=167 N/mm ²		f=1/200L F (kN)	f=1/360L F (kN)	F(kN)
	Fmax(kN)	fmax(mm)	Fmax(kN)	fmax(mm)			
250	-	-	-	-	-	-	20.277
500	-	-	-	-	-	-	20.081
750	4.964	1.20	9.928	1.50	-	-	18.443
1000	3.723	2.14	7.446	2.67	-	-	15.245
1250	2.977	3.34	5.955	4.18	-	4.944	12.557
1500	2.482	4.82	4.964	6.02	-	3.434	10.507
1750	2.124	6.55	4.248	8.19	-	2.521	8.966
2000	1.859	8.56	3.718	10.70	3.473	1.923	7.789
2250	1.653	10.84	3.306	13.55	2.747	1.521	6.867
2500	1.486	13.38	2.972	16.73	2.217	1.236	6.141
2750	1.354	16.19	2.708	20.24	1.834	1.020	5.543
3000	1.241	19.27	2.482	24.09	1.540	0.853	5.042

Art.Nr.	P	L (m)
P5511223	2	3
P5511226	2	6
P5511236	3	6

P5000T

T= 14 x 28 mm

41

83

2,5mm

2.5

Y
X
Z

A = 5.06 cm²
 ρ/m = 4.05 kg/m
 I y-y = 37.76 cm⁴
 Z y-y = 9.01 cm³
 r y-y = 2.72 cm
 I z-z = 16.95 cm⁴
 Z z-z = 8.21 cm³
 r z-z = 1.82 cm

2 3

L(mm)	σ=132 N/mm ²		σ=132 N/mm ²		f=1/200L F (kN)	f=1/360L F (kN)	F(kN)
	Fmax(kN)	fmax(mm)	Fmax(kN)	fmax(mm)			
250	-	-	-	-	-	-	19.620
500	-	-	-	-	-	-	19.355
750	6.298	0.71	12.596	0.89	-	-	16.422
1000	4.724	1.27	9.447	1.59	-	-	12.822
1250	3.777	1.98	7.554	2.48	-	-	10.124
1500	3.149	2.86	6.298	3.58	-	-	8.182
1750	2.698	3.89	5.396	4.86	-	-	6.769
2000	2.359	5.09	4.719	6.36	-	4.120	5.719
2250	2.099	6.44	4.199	8.05	-	3.257	4.934
2500	1.888	7.94	3.777	9.93	-	2.639	4.326
2750	1.717	9.62	3.434	12.02	-	2.178	3.846
3000	1.575	11.45	3.149	14.31	-	1.834	3.453

Art.Nr.	P	L (m)
P5011223	2	3
P5011226	2	6
P5011236	3	6

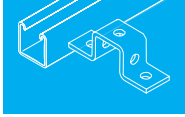

UNISTRUT P8000

3.0

$A = 6.36 \text{ cm}^2$
 $\rho/m = 5.39 \text{ kg/m}$
 $I_{y-y} = 51.8 \text{ cm}^4$
 $Z_{y-y} = 11.4 \text{ cm}^3$
 $r_{y-y} = 2.85 \text{ cm}$
 $I_{z-z} = 27.77 \text{ cm}^4$
 $Z_{z-z} = 9.92 \text{ cm}^3$
 $r_{z-z} = 2.09 \text{ cm}$

P8000T

2

L(mm)	σ=160 N/mm ²		σ=160 N/mm ²		f=1/200L	f=1/360L
	Fmax(kN)	fmax(mm)	Fmax(kN)	fmax(mm)	F (kN)	F (kN)
250	-	-	-	-	-	-
500	14.58	0.35	29.160	0.44	-	-
750	9.71	0.79	19.424	0.98	-	-
1000	7.27	1.40	14.541	1.75	-	-
1250	5.81	2.19	11.610	2.73	-	-
1500	4.83	3.15	9.650	3.93	-	-
1750	4.13	4.29	8.250	5.35	-	7.481
2000	3.60	5.60	7.190	6.98	-	5.700
2250	3.19	7.10	6.370	8.84	-	4.471
2500	2.86	8.78	5.710	10.91	-	3.588
2750	2.59	10.64	5.170	13.21	-	2.929
3000	2.36	12.66	4.710	15.71	4.479	2.427

Art.Nr.	P	L (m)
P8012523	2	3
P8012526	2	6

UNISTRUT P3301 & P1001

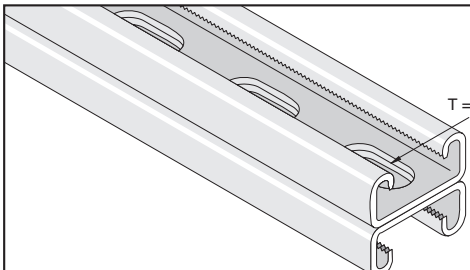

T = 11 x 25 mm

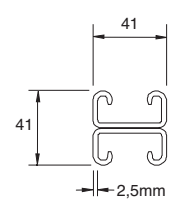
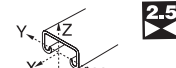
2.5

A = 3.94 cm²
 ρ/m = 3.53 kg/m
 I y-y = 5.62 cm⁴
 Z y-y = 2.72 cm³
 r y-y = 1.19 cm
 I z-z = 10.58 cm⁴
 Z z-z = 5.12 cm³
 r z-z = 1.63 cm

2 3 4 4 304/A2

P3301T10

L (mm)	σ=175 N/mm ²		σ=175 N/mm ²		f=1/200L	f=1/360L	F (kN)
	Fmax (kN)	fmax (mm)	Fmax (kN)	fmax (mm)	F (kN)	F (kN)	
250	7.613	0.21	15.225	0.26	-	-	17.266
500	3.806	0.86	7.613	1.07	-	-	17.030
750	2.536	1.94	5.072	2.42	-	4.365	16.599
1000	1.903	3.44	3.806	4.30	-	2.453	15.667
1250	1.521	5.38	3.041	6.72	2.825	1.570	14.156
1500	1.265	7.74	2.531	9.68	1.962	1.089	12.478
1750	1.084	10.54	2.168	13.18	1.442	0.795	10.899
2000	0.952	13.77	1.903	17.21	1.099	0.608	9.496
2250	0.844	17.42	1.687	21.78	0.873	0.481	8.289*
2500	0.760	21.49	1.521	26.86	0.706	0.392	7.250*
2750	0.692	26.03	1.383	32.54	0.579	0.324	6.377*
3000	0.633	30.98	1.265	38.73	0.491	0.265	-

Art.Nr.	P	L (m)
P3321323	2	3
P3321326	2	6
P3331336	3	6
P3321346	4	6
P3321396	4 (304/A2)	6

P 3



- GB** Continuously seam welded
- NL** Volledig lengte gelast
- F** Soudure complet
- D** Längsverschweißt
- N** Fortannet
- S** Helsvetsad

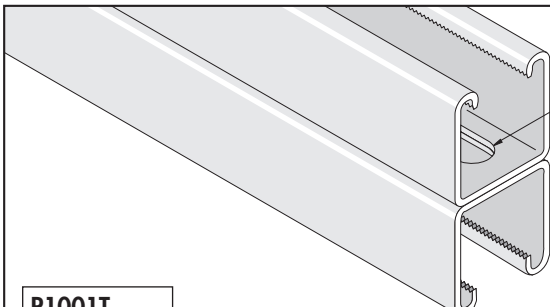

*k.L/r =>180 < 250

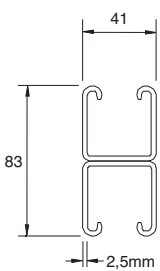

T = 14 x 28 mm

2.5

A = 6.00 cm²
 ρ/m = 5.47 kg/m
 I y-y = 36.21 cm⁴
 Z y-y = 8.77 cm³
 r y-y = 2.45 cm
 I z-z = 18.34 cm⁴
 Z z-z = 8.88 cm³
 r z-z = 1.74 cm

2 3 4 4 304/A2

P1001T

L (mm)	σ=175 N/mm ²		σ=175 N/mm ²		f=1/200L	f=1/360L	F (kN)
	Fmax (kN)	fmax (mm)	Fmax (kN)	fmax (mm)	F (kN)	F (kN)	
250	-	-	-	-	-	-	27.458
500	-	-	-	-	-	-	27.311
750	8.182	0.97	16.363	1.21	-	-	27.027
1000	6.136	1.72	12.272	2.15	-	-	26.585
1250	4.910	2.69	9.820	3.36	-	-	25.830
1500	4.091	3.87	8.182	4.84	-	7.034	24.584
1750	3.057	5.27	7.014	6.59	-	5.170	22.906
2000	3.066	6.89	6.131	8.61	-	3.953	21.042
2250	2.727	8.72	5.454	10.90	-	3.120	19.198
2500	2.453	10.77	4.905	13.46	4.552	2.531	17.452
2750	2.232	13.02	4.464	16.28	3.767	2.090	15.852
3000	2.045	15.50	4.091	19.38	3.159	1.756	14.391*

Art.Nr.	P	L (m)
P1021223	2	3
P1021226	2	6
P1031236	3	6
P1021246	4	6
P1021296	4 (304/A2)	6

P 3

- GB** Continuously seam welded
- NL** Volledig lengte gelast
- F** Soudure complet
- D** Längsverschweißt
- N** Fortannet
- S** Helsvetsad



*k.L/r =>180 < 250

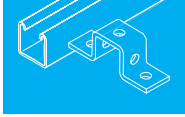

UNISTRUT P5501 & P5001

2.5

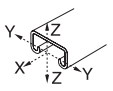

$A = 8.06 \text{ cm}^2$
 $\rho/m = 7.21 \text{ kg/m}$
 $I_{y-y} = 109.74 \text{ cm}^4$
 $Z_{y-y} = 17.70 \text{ cm}^3$
 $r_{y-y} = 3.69 \text{ cm}$
 $I_{z-z} = 26.14 \text{ cm}^4$
 $Z_{z-z} = 12.66 \text{ cm}^3$
 $r_{z-z} = 1.80 \text{ cm}$

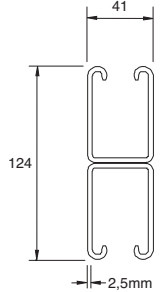

41

124

2.5mm

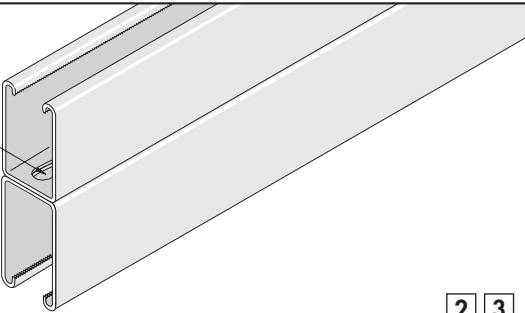

T = 14 x 28 mm

2 3

L(mm)	$\sigma=167 \text{ N/mm}^2$		$\sigma=167 \text{ N/mm}^2$		$f=1/200L$	$f=1/360L$	F(kN)
	Fmax(kN)	fmax(mm)	Fmax(kN)	fmax(mm)	F (kN)	F (kN)	
250	-	-	-	-	-	-	34.747
500	-	-	-	-	-	-	34.590
750	-	-	-	-	-	-	34.257
1000	-	-	-	-	-	-	33.766
1250	-	-	-	-	-	-	32.971
1500	7.873	2.46	15.745	3.07	-	-	31.667
1750	6.749	3.34	13.499	4.18	-	-	29.822
2000	5.906	4.38	11.811	5.47	-	-	27.674
2250	5.248	5.54	10.497	6.92	-	9.476	25.457
2500	4.724	6.83	9.447	8.54	-	7.671	23.299
2750	4.292	8.27	8.584	10.34	-	6.337	21.288
3000	3.934	9.84	7.868	12.30	-	5.327	19.443

Art.Nr.	P	L (m)
P5521226	2	6
P5521236	3	6

2.5

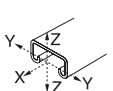

$A = 10.12 \text{ cm}^2$
 $\rho/m = 8.11 \text{ kg/m}$
 $I_{y-y} = 243.16 \text{ cm}^4$
 $Z_{y-y} = 29.44 \text{ cm}^3$
 $r_{y-y} = 4.90 \text{ cm}$
 $I_{z-z} = 33.90 \text{ cm}^4$
 $Z_{z-z} = 16.42 \text{ cm}^3$
 $r_{z-z} = 1.83 \text{ cm}$

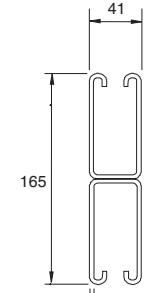

41

165

2.5mm

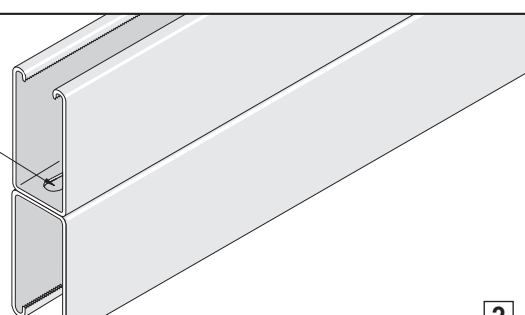

T = 14 x 28 mm

2

L(mm)	$\sigma=132 \text{ N/mm}^2$		$\sigma=132 \text{ N/mm}^2$		$f=1/200L$	$f=1/360L$	F(kN)
	Fmax(kN)	fmax(mm)	Fmax(kN)	fmax(mm)	F (kN)	F (kN)	
250	-	-	-	-	-	-	34.266
500	-	-	-	-	-	-	34.129
750	-	-	-	-	-	-	33.825
1000	-	-	-	-	-	-	33.432
1250	12.267	1.00	24.535	1.25	-	-	32.864
1500	10.222	1.44	20.444	1.80	-	-	32.010
1750	8.760	1.96	17.521	2.45	-	-	30.764
2000	7.667	2.56	15.333	3.20	-	-	29.165
2250	6.813	3.24	13.626	4.05	-	-	27.350
2500	6.131	4.00	12.263	5.00	-	-	25.467
2750	5.577	4.84	11.154	6.05	-	-	23.613
3000	5.111	5.77	10.222	7.21	-	-	21.847

Art.Nr.	P	L (m)
P5021226	2	6

SUPPORT SYSTEMS

TYCEULSUP 0311

UNISTRUT P8001

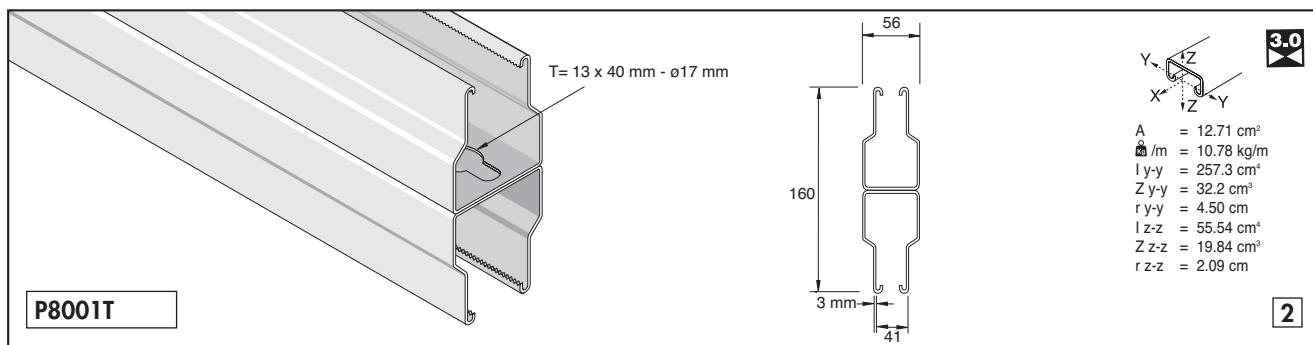

L(mm)	σ=160 N/mm ²		σ=175 N/mm ²		f=1/200L	f=1/200L
	Fmax(kN)	fmax(mm)	Fmax(kN)	fmax(mm)	F (kN)	F (kN)
250	-	-	-	-	-	-
500	-	-	-	-	-	-
750	-	-	-	-	-	-
1000	21.00	0.79	41.000	0.99	-	-
1250	16.43	1.24	32.856	1.55	-	-
1500	13.67	1.79	27.330	2.23	-	-
1750	11.69	2.44	23.380	3.04	-	-
2000	10.21	3.19	20.410	3.97	-	-
2250	9.05	4.03	18.090	5.03	-	-
2500	8.12	4.99	16.238	6.21	-	-
2750	7.36	6.04	14.713	7.51	-	-
3000	6.72	7.19	13.44	8.94	-	12.510

Art.Nr.	P	L (m)
P8022526	2	6



UNISTRUT

Schiene zum Einbetonieren **D** Ankerskinner **N** Ankarskena **S**

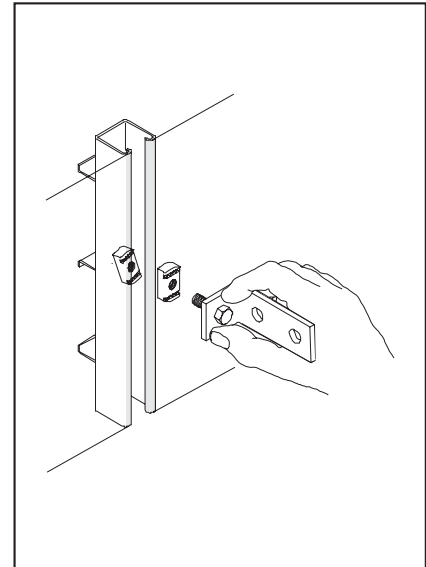
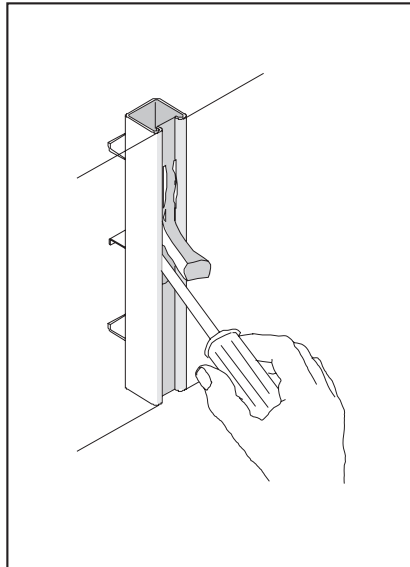
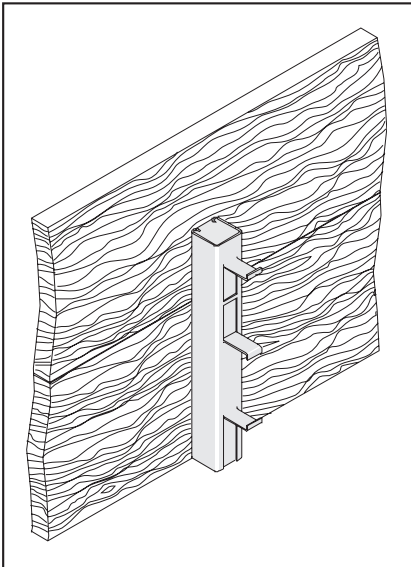

Concrete inserts **GB** Beton invoegers **NL** Inserts béton **F**

GB Concrete Inserts

Unistrut concrete inserts are manufactured from the standard Unistrut section and may be installed in floors, walls or ceilings, for the support of all types of piping, conduit, cable support and other industrial equipment.

Unistrut nuts can be inserted anywhere along the length of the insert, providing a means of attaching all kinds of fittings or rods where required.

Unistrut inserts are available pre-filled with an easily removable foam, this is to prevent the ingress of grout and cement.

Concrete inserts can be supplied in pre galvanised, hot dip galvanized and stainless steel finish. Details on request.

NL Betoninvoegers

Unistrut betoninvoegers zijn vervaardigd uit normale Unistrut profielen en kunnen worden geïnstalleerd in vloeren, wanden en plafonds om pijpbevestigingen, electrotechnische installaties en alle denkbare industriële ondersteuning aan te bevestigen.

Unistrut glijmoeren kunnen op elke positie in het profiel worden geplaatst en zorgen voor een perfecte bevestiging van Unistrut hulpstukken of draadstangen. Unistrut betoninvoegers worden geleverd met een eenvoudig te verwijderen schuim wat indringen van beton in het profiel tegengaat.

De profielen worden geleverd in sendzimir verzinkt kwaliteit of in roestvrijstaal 316 (A4).

F Inserts béton

Les profils inserts Unistrut sont fabriqués à partir du profil standard Unistrut.

Ils peuvent être installés dans les murs et les planchers et peuvent recevoir les supports de cables, de tubes et tous types de conduites.

Les écrous Unistrut peuvent être fixés à n'importe quel endroit du profil.

Les profils inserts sont remplis de mousse phénolique, non inflammable et facilement retirable. Elle est destinée à empêcher le ciment de se mettre à l'intérieur du profil.

Les profils inserts se font aussi en acier galvanisé à chaud et en inox.

D Schienen zum Einbetonieren

Unistrut Schienen zum Einbetonieren werden aus Standard - Unistrut - Schienen hergestellt und können in Böden, Wänden oder Decken zur Halterung von allen möglichen Arten von Rohrleitungen, Kabelbühnen und anderen industriellen Einrichtungen installiert werden.

Unistrut Schienenmutter können an jeder beliebigen Stelle entlang der einbetonierten Schiene eingesetzt werden und sorgen für eine perfekte Befestigung von Verbindungsteilen oder Gewindestangen, wo gefordert.

Unistrut Schienen zum Einbetonieren sind mit einem leicht zu entfernenden Schaum vorgefüllt erhältlich um das Eindringen von Mörtel und Zement zu verhindern. Schienen zum Einbetonieren können in sendzimirverzinkt, feuerverzinkt und Edelstahl (1.4571, A4) geliefert werden. Details auf Anfrage.

N Ankerskinner

Unistrut ankerskinner produseres av standard Unistrut skinner med utstansede klør i ryggen. De kan monteres i tak, vegger eller gulv for innfesting av alle typer installasjoner som for eksempel rør, kabler, kabelstiger, ventilasjonsutstyr etc.

Unistrut muttere kan settes inn på ethvert punkt langs ankerskinnens åpning, og gi feste for konsoller, konstruksjonsdeler eller stag.

Unistrut ankerskinner leveres fylt med skum som enkelt kan fjernes. Dette hindrer inntrengning av betong og slam i skinnen under støping. Ankerskinner leveres pregalvanisert, varmforsinket eller i syrefast stål.

Det anbefales ikke å belaste ankerskinnene med full belastning med avstand mindre enn 50 mm fra endene. Hvis dette er nødvendig må endene forsterkes. Be om nærmere opplysninger.

S Ankarskenor

Unistrut ankarskenor är tillverkade av sektioner av vanliga standardskenor. De kan installeras i golv, väggar och tak för stöd och upphängning av alla typer av rör, kabelstegar och annan industriell utrustning.

Unistrutmutter kan installeras längs hela skenan, vilket möjliggör installation av upphängningar och pendlar där de erfordras.

Unistrut ankarskenor gör att få fylla med ett skum, som är enkelt att avlägsna. Detta för att hindra murbruk eller cement att komma in i skenan. Ankarskenor kan fås förgalvaniserade, varmgalvaniserade eller i rostfritt stål. Mer information fås på förfrågan.

UNISTRUT

GB Concrete inserts

NL Betoninvoegers

F Inserts béton

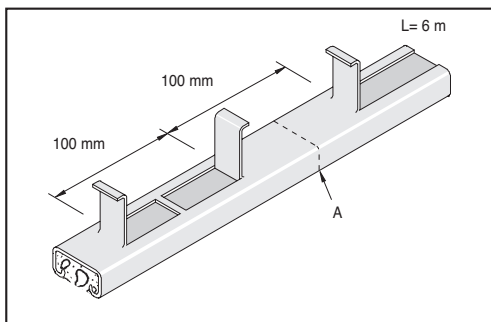
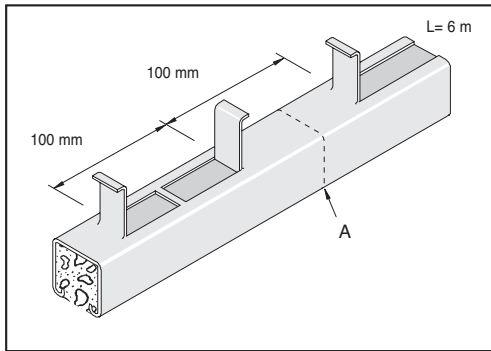

D Schiene zum Einbetonieren

N Ankerskinner

S Ankarskena

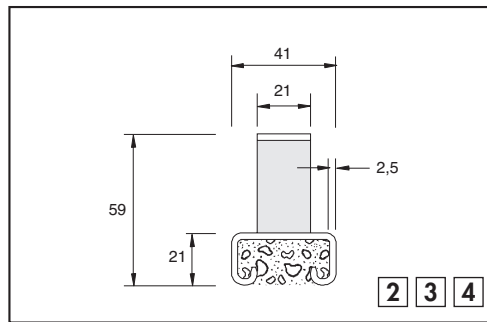
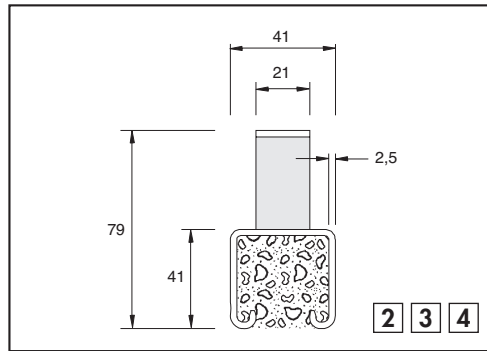

P3270

Art.nr.	P
P3270	2
P3270H	3
P3270SS	4

P3370

Art.nr.	P
P3370	2
P3370H	3
P3370SS	4

GB The inserts are designed to accommodate M6, M8, M10, M12 & M16 fixings. Normal cutting positions are between lugs as indicated. (A)

Non standard lengths can be supplied in increments of 200mm

Recommended loading on the inserts in average strength concrete* with a safety factor of approximately 3, is as follows:

P3270: Inserts 300mm and over 8,8 kN pull out per 300mm.

P3370: Inserts 300mm and over 6,7 kN pull out per 300mm.

*B = 25 N/mm²

NL De betoninvoegers zijn ontworpen om M6, M8, M10, M12 & M16 bevestigingen toe te passen. Normale posities om het profiel af te korten zijn hierboven aangegeven. (A)

Korte invoegers zijn leverbaar in lengtes van veelvoud van 200 mm.

Maximale belastingen op de invoegers in gemiddelde kwaliteit beton* met een veiligheidsfactor van 3 is als volgt:

P3270: Uittrekwaarde van een invoeger van 300 mm en langer: 8,8 kN per 300 mm lengte.

P3370: Uittrekwaarde van een invoeger van 300 mm en langer: 6,7 kN per 300 mm lengte.

F Acier étiré à froid pré-galvanisé
Longueur standard: 6m
Pds: 16,64 kg par longueur
Cl 10 est prévu pour recevoir les écrous M6, M8, M10, M12, et M16. Les coupes sont à effectuer à mi-distance des pattes de scellement. (A)

Charges admissibles* P3270

Pour une longueur minimum scellée de 300 mm la charge est de 900 DaN tous les 300 mm. Coefficient de sécurité: 3

Charges admissibles* P3370

Pour une longueur minimum scellée de 300 mm la charge est de 680 DaN tous les 300 mm. Coefficient de sécurité: 3

D 41 mm x 41 mm x 2,5 mm Materialstärke
Schiene zum Einbetonieren wurden zur Aufnahme von M6, M8, M10, M12 & M16 Befestigungen entwickelt. Die Schnittstelle wird normalerweise wie angezeigt zwischen den Haken platziert.

Abweichende Längen vom Standardmaß können in Schritten von 200 mm geliefert werden.

Empfohlene Lasten auf die Schienen einbetoniert in durchschnittlichem Beton betragen mit einem ungefähren Sicherheitsfaktor von 3: Schienen zum Einbetonieren mit einer Länge von 300 mm und größer: Max. zulässige Zugkraft 8,8 kN je 300 mm Schienenlänge

P3270: Max. zulässige Zugkraft 8,8 kN je 300 mm Schienenlänge

P3370: Max. zulässige Zugkraft 6,7 kN je 300 mm Schienenlänge

N Ankerskinne kan benyttes med Unistrut muttere i dimensjonene M6, M8, M10 og M12. Skinnen kan kappes mellom klørne som vist på tegning (A). Minste kappelengde er 200 mm.

Anbefalt belastning på ankerskinne i normalt god betong* med en sikkerhetsfaktor på 3 for skinner med lengde over 300mm:

P3270: 8,8 kN uttrekk pr. 300mm skinne.

P3370: 6,7 kN uttrekk pr. 300mm skinne.

S P3270 & P3370 är konstruerade för att passa till M6, M8, M10 och M12 muttrar. Normal position för kapning är mellan flänsarna som det visas på bilden ovan (A).

Skenan kan levereras i alla längder med 200mm intervall.

Rekommenderad last i en ankarskena i vanlig cement* med en säkerhetsfaktor på ca. 3, är följande:

Ankarskenor som är 300mm och längre

P3270: 8,8 kN utdragslast per 300mm.

P3370: 6,7 kN utdragslast per 300mm.

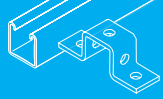

UNISTRUT

Schienenmutter für Unistrut Schienen **D** Skinnemutter for Unistrut skinner **N** Skenmutter för Unistrut skenor **S**

5	Art. Nr.	3	Art. Nr.	4	Art. Nr.	H (mm)	/100
M6	PNL06ZP	M6	PNL06HDIN	M6	PNL06SS	6,50	3,26
M8	PNL08ZP	M8	PNL08HDIN	M8	PNL08SS	8	3,53
M10	PNL10ZP	M10	PNL10HDIN	M10	PNL10SS	9	3,95
M12	PNL12ZP	M12	PNL12HDIN	M12	-	12	4,78
M12	PNL12AZP	M12	PNL12AHDIN	M12	PNL12ASS	9	3,43

5	Art. Nr.	3	Art. Nr.	4	Art. Nr.	H (mm)	/100
M6	PNS06ZP	M6	PNS06HDIN	M6	PNS06SS	6,50	6,5
M8	PNS08ZP	M8	PNS08HDIN	M8	PNS08SS	8	8
M10	PNS10ZP	M10	PNS10HDIN	M10	PNS10SS	9	9
M12	PNS12AZP	M12	PNS12AHDIN	M12	PNS12ASS	9	9

5	Art. Nr.	3	Art. Nr.	4	Art. Nr.	H (mm)	/100
M6	PNP06ZP	M6	PNP06HDIN	M6	PNP06SS	6,50	3,10
M8	PNP08ZP	M8	PNP08HDIN	M8	PNP08SS	8	3,40
M10	PNP10ZP	M10	PNP10HDIN	M10	PNP10SS	9	3,80
M12	PNP12ZP*	M12	PNP12HDIN*	M12	-	11	4,68
M12	PNP12AZP	M12	PNP12AHDIN	M12	PNP12ASS	9	3,43

5	Art. Nr.	4	Art. Nr.	H (mm)	/100
M16	PNP16ZP*	M16	PNP16SS*	12	8,00

Channel nuts for Unistrut channels **GB** Glijmoeren voor Unistrut profielen **NL** Plaques taraudées pour rails Unistrut **F**

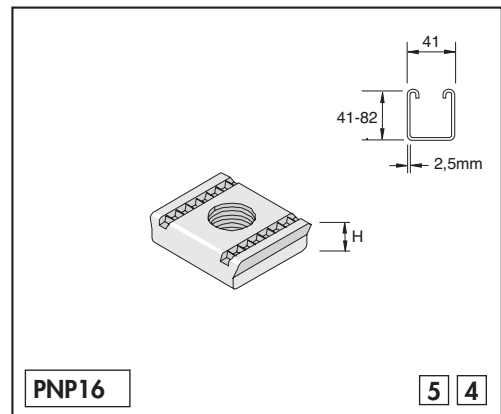
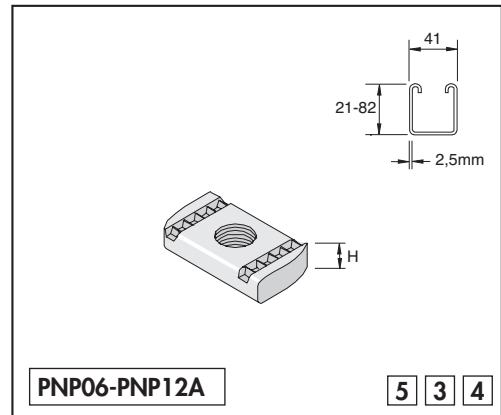
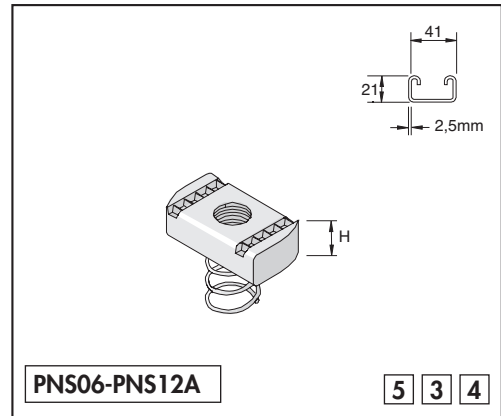
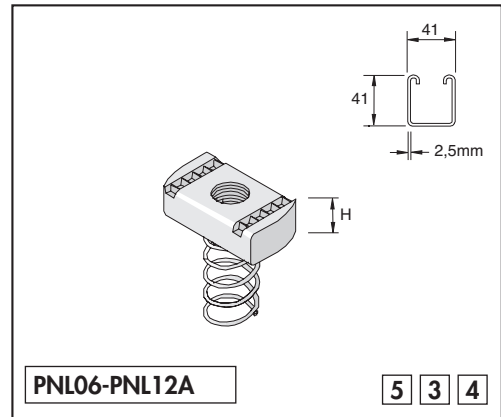

* Not suitable for Unistrut channels P3300 & P4000, P3370
 * Niet geschikt voor Unistrut profielen P3300 & P4000, P3370
 * Ne pas utiliser avec rails Unistrut P3300 & P4000, P3370
 * nicht für Unistrut Schienen P3300 & P4000, P3370
 * Kan ikke brukes til skinner P3300, P4000 og P3370
 * Ej för Unistrut skenor P3300, P4000 & P3370

UNISTRUT

GB Channel nut performance in Unistrut channel

NL Belastingsgegevens van Unistrut glijmoeren





F Résistance de la plaque taraudée dans les rails Unistrut

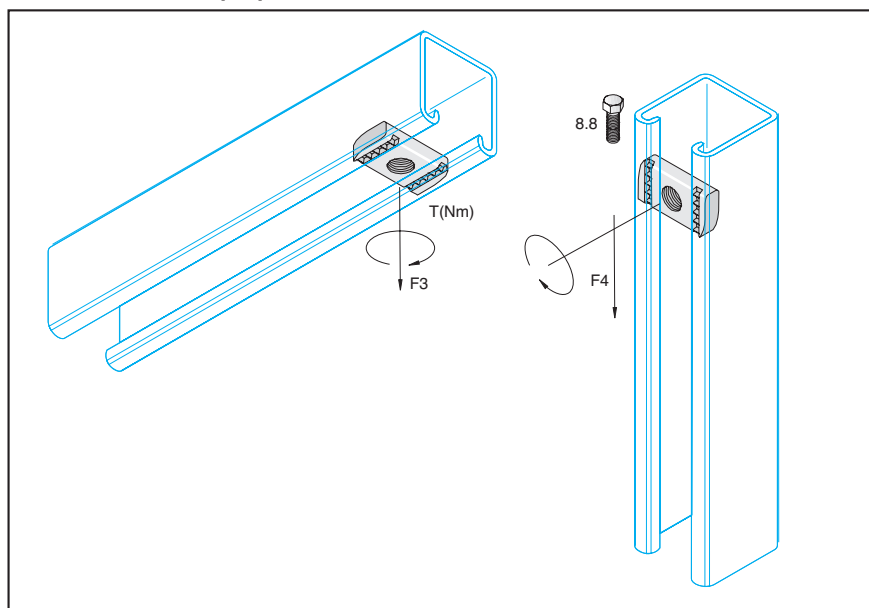

D Lastwerte für Schienenmutter in Unistrut Schienen

N Tillatt belastning for Unistrut muttere

S Installationsbeskrivning för skenmutter



	Art. Nr. [5]	T (Nm)	F3 kN	F4 kN
 41 [2]	PNP06ZP	12	4,70	0,49
	PNP08ZP	28	5,78	1,56
	PNP10ZP	55	6,86	3,40
	PNP12ZP	95	8,82	5,88
	PNP16ZP	125	10,30	7,35
	M16SN*	95	8,82	
 21 41 [2]	PNP06ZP	12	4,70	0,49
	PNP08ZP	28	5,78	1,56
	PNP10ZP	55	6,86	3,40
	PNP12AZ	60	6,86	2,64
	M16SN*	95	8,82	
 21 41 [2]	PNP06ZP	12	3,33	0,49
	PNP08ZP	28	3,53	1,56
	PNP10ZP	40	3,92	1,66
	PNP12AZP	40	4,41	1,96
	M16SN*	40	3,92	
 41 [2]	PNP06ZP	12	3,45	0,49
	PNP08ZP	28	4,65	1,56
	PNP10ZP	55	5,4	2,5
	PNP12ZP	55	6,6	4,55
 21 41 [2]	PNP06ZP	12	3,45	0,49
	PNP08ZP	28	4,65	1,56
	PNP10ZP	55	5,4	2,5
	PNP12AZP	55	5,65	4,55

	Art. Nr. [4]	T (Nm.)	F3 kN	F4 kN
 41 [4]	PNP06SS	6,5	2,45	0,19
	PNP08SS	16	4,41	0,49
	PNP10SS	31,5	6,86	1,17
	PNP12ASS	55	6,86	1,66
	PNP16SS	125	10,30	3,92
 21 41 [4]	PNP06SS	6,5	2,45	0,19
	PNP08SS	16	4,41	0,49
	PNP10SS	31,5	6,86	1,17
	PNP12ASS	55	6,86	1,66

*M16SN Hot forged
Warm gesmeed
Laminé à chaud
Warm geschmiedet
Smijern
Varmsmidd

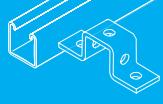
Hammerkopfschrauben für Unistrut Schienen **D**
Unistrut hakebolt **N**
Unistrut pendelmutter **S**
Unistrut stud nuts **GB**
Hamerkop bouten **NL**
Boulon à tête marteau Unistrut **F**

Art. Nr.	L	
M6 x 30SN	18,5 mm	100

Art. Nr.	Art. Nr.	L	
M8 x 30SN		15,5 mm	100
M8 x 40SN	M8 x 40SNSS	25,5 mm	100
M8 x 50SN		35,5 mm	100
M8 x 60SN		45,5 mm	100
M8 x 75SN		60,5 mm	100
M8 x 100SN		85,5 mm	100

Art. Nr.	Art. Nr.	L	
M10 x 30SN		13 mm	100
M10 x 40SN	M10 x 40SNSS	23 mm	100
M10 x 50SN		33 mm	100
M10 x 60SN		43 mm	100
M10 x 75SN		58 mm	100
M10 x 100SN		83 mm	100

Art. Nr.	Art. Nr.	L	
M12 x 30SN		11 mm	100
M12 x 40SN	M12 x 40SNSS	21 mm	100
M12 x 50SN		31 mm	100
M12 x 60SN		41 mm	100
M12 x 75SN		56 mm	100
M12 x 100SN		81 mm	100

Art. Nr.	L	
M16 x 63SN*	40 mm	100
M16 x 102SN*	79 mm	100

- * Hot forged
- * Warm gesmeed
- * Laminé à chaud
- * Warm geschmiedet
- * Smijern
- * Varmsmidd

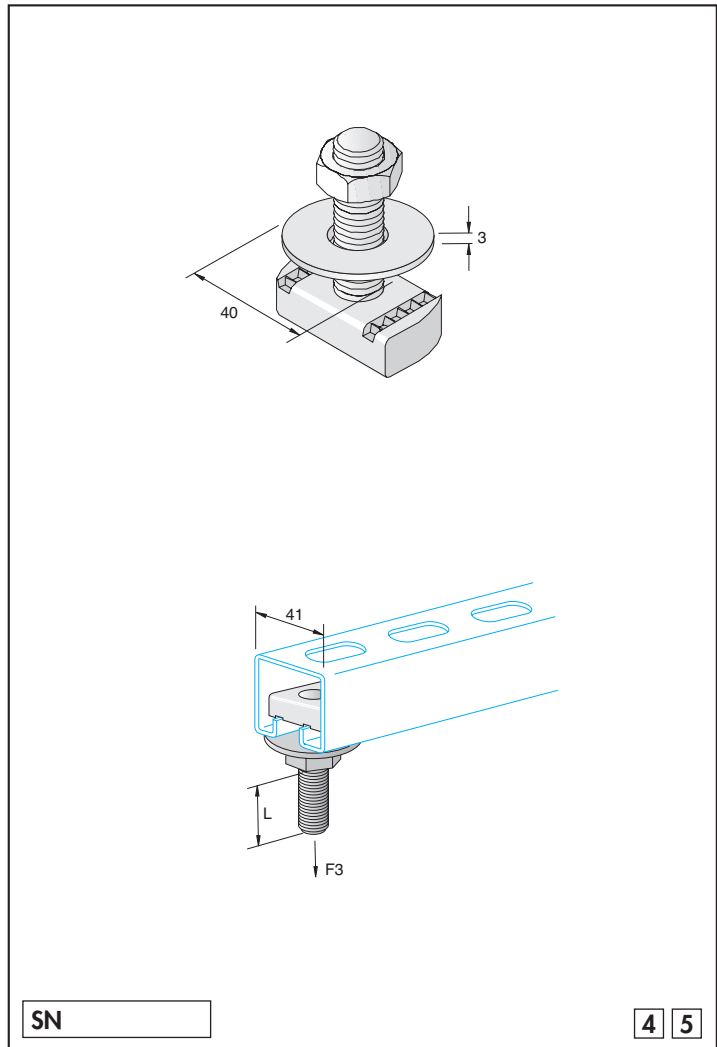

UNISTRUT

GB Flat fittings

NL Platte hulpstukken

F Plats

D Verbindungsplatten

N Flate konstruksjonsdeler

S Plana fästdetaljer

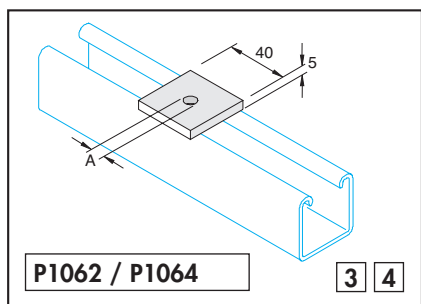

3	4	A (mm)	Ø	h	l
P1062	P1062SS	8	M6	0,072	100
P1062A	P1062ASS	10	M8	0,071	100
P1063	P1063SS	12	M10	0,070	100
P1064	P1064SS	14	M12	0,068	100

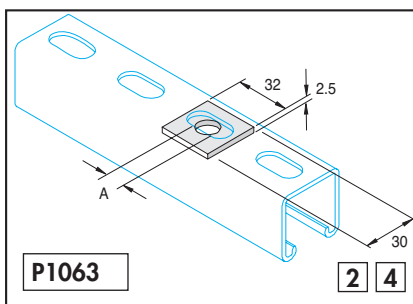

2	4	A (mm)	Ø	h	l
P1063/06	P1063/06SS	8	M6	0,072	100
P1063/08	P1063/08SS	10	M8	0,071	100
P1063/10	P1063/10SS	12	M10	0,070	100
P1063/12	P1063/12SS	14	M12	0,068	100

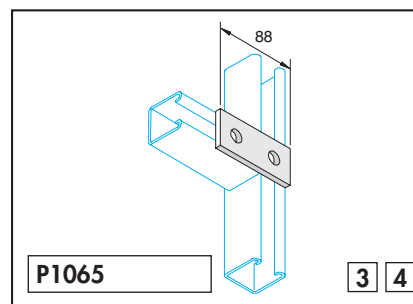

3	4	h	l
P1065	P1065SS	0,160	50

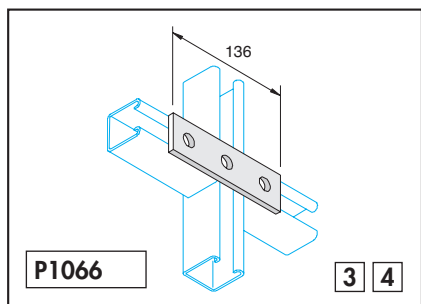

3	4	h	l
P1066	P1066SS	0,240	25

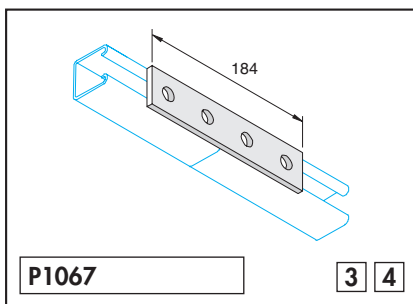

3	4	h	l
P1067	P1067SS	0,311	25

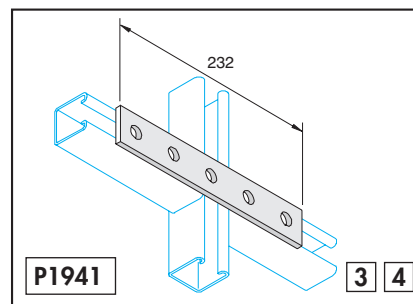

3	4	h	l
P1941	P1941SS	0,400	25

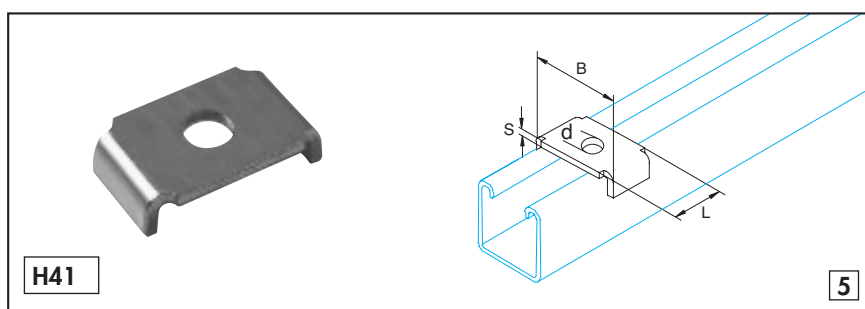

Art. Nr.	D (mm)	S (mm)	B (mm)	h /100	l
1404110	8,5	4	26	4,1	100
1404120	10,5	4	26	4,0	100
1404130	12,5	4	26	3,9	100

SUPPORT SYSTEMS

TYCEUELSUP 0311

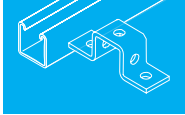

UNISTRUT

Verbindungsplatten **D**
 Flate konstruksjonsdeler **N**
 Plana fästdetaljer **S**

Flat fittings **GB**
 Platte hulpstukken **NL**
 Pièces de raccordements **F**

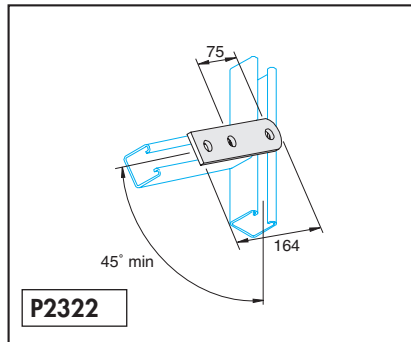

P2322

3	4	⚙️	📏
P2322	0,305	25	

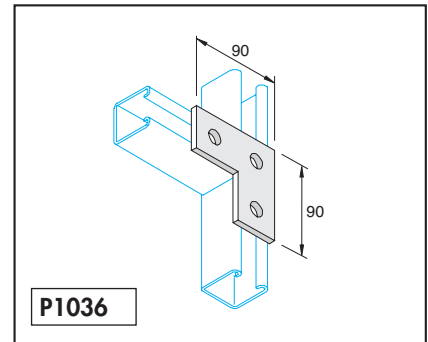

P1036

3	4	⚙️	📏
P1036	P1036SS	0,250	25

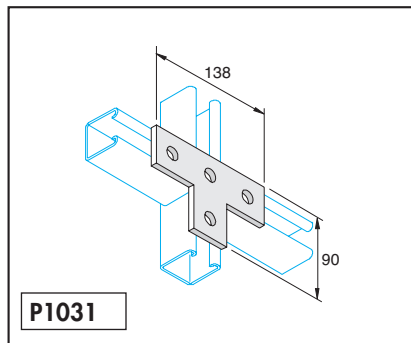

P1031

3	4	⚙️	📏
P1031	P1031SS	0,3040	25

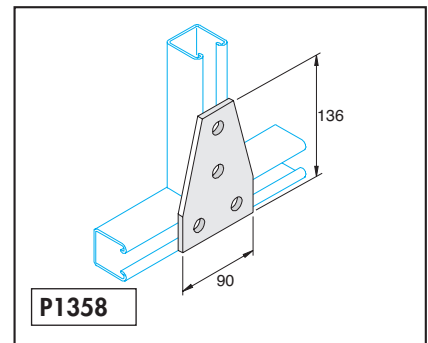

P1358

3	4	⚙️	📏
P1358	P1358SS	0,450	10

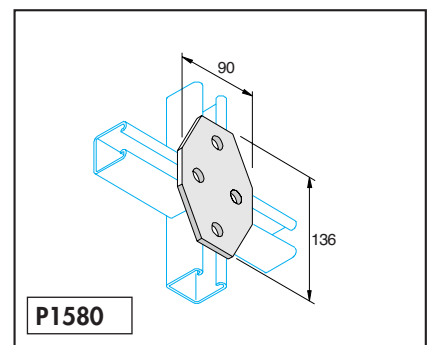

P1580

3	4	⚙️	📏
P1580	P1580SS	0,470	10

SUPPORT SYSTEMS

UNISTRUT

- GB** Angle fittings
- NL** Gebogen hulpstukken
- F** Angles d'assemblages

- D** Winkelverbinder divers
- N** Konstruksjonsdeler i vinkel
- S** Vinkelfästen

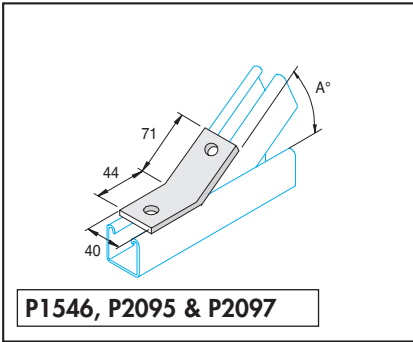

P1546, P2095 & P2097

3	4	A°	Weight	Length
P1546	P1546SS	45°	0,252	25
P2097		60°	0,246	25

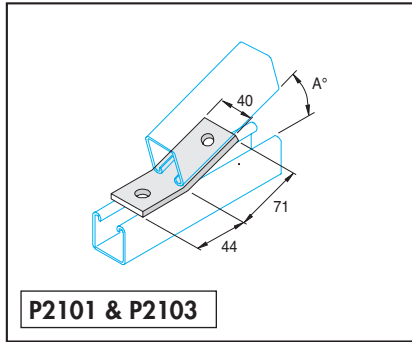

P2101 & P2103

3	A°	Weight	Length
P2101	30°	0,246	25

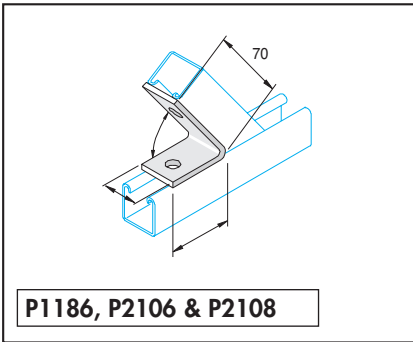

P1186, P2106 & P2108

3	4	A°	Weight	Length
P1186	P1186SS	45°	0,246	25

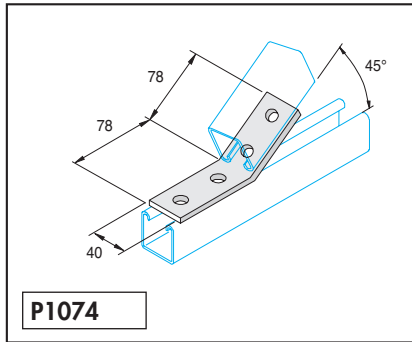

P1074

3	4	Weight	Length
P1074	P1074SS	0,311	25

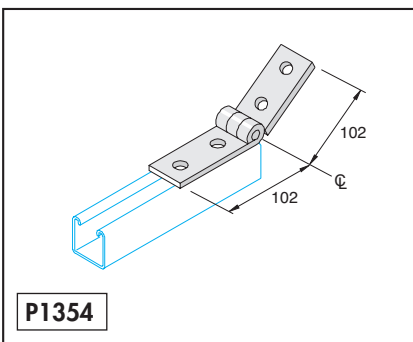

P1354

5	Weight	Length
P1354	0,452	10

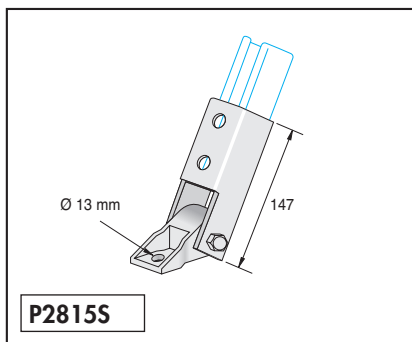

P2815S

5	Weight	Length
P2815S	0,2	10

SUPPORT SYSTEMS

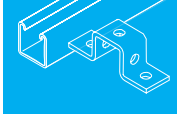

UNISTRUT

Winkelverbinder 90° **D**
 Konstruksjonsdeler 90° **N**
 Vinkelfästen 90° **S**

Angle fittings 90° **GB**
 Gebogen hulpstukken 90° **NL**
 Pièces de raccordements 90° **F**

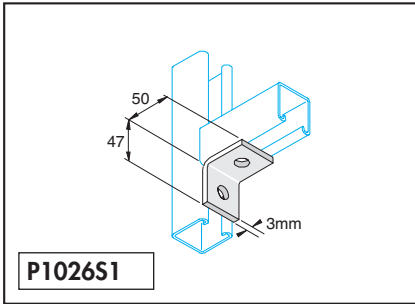

5		
P1026-S1	0,071	100

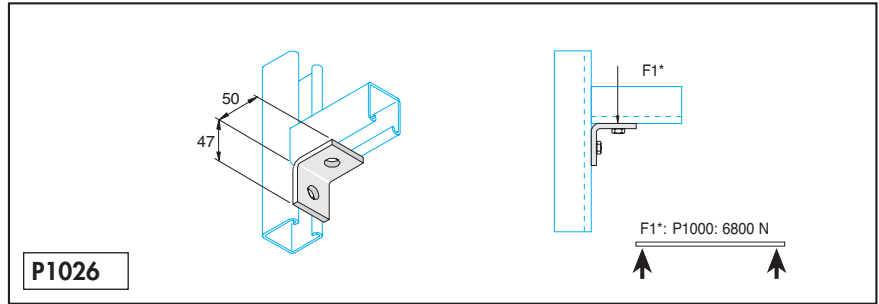

3	4	
P1026	P1026SS	0,150 50

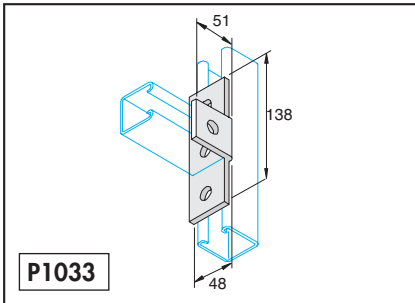

3	4	
P1033	P1033SS	0,340 25

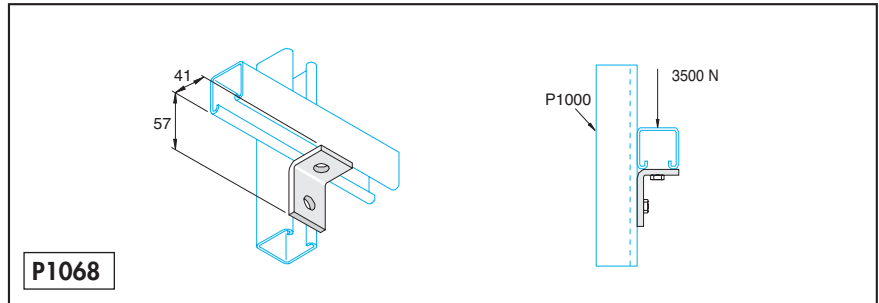

3	4	
P1068	P1068SS	0,150 50

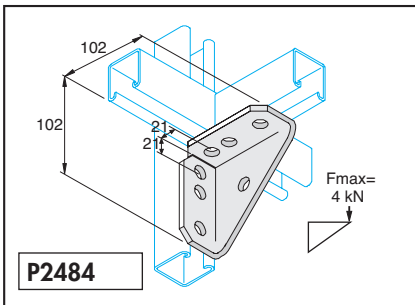

3	4	
P2484	P2484SS	0,560 10

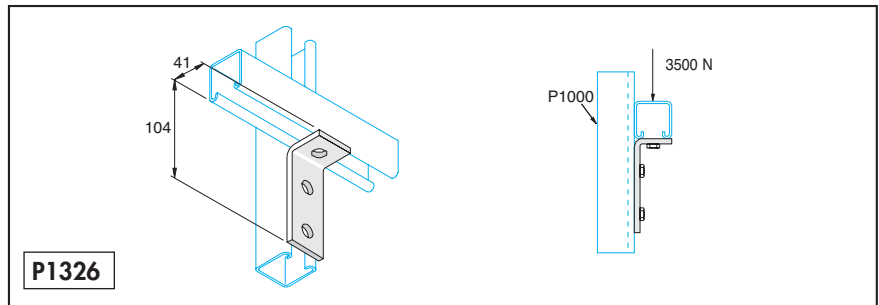

3	4	
P1326	P1326SS	0,240 25

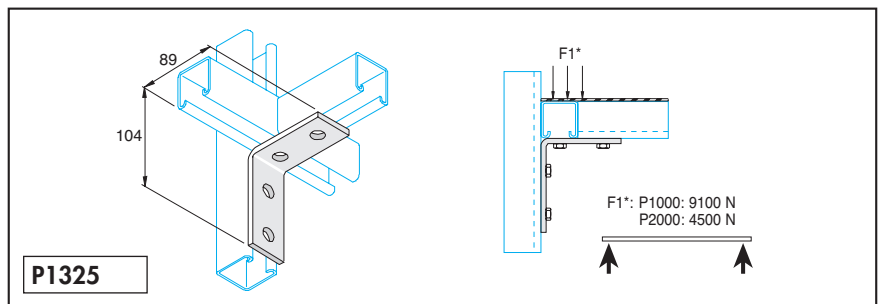

3	4	
P1325	P1325SS	0,311 25

SUPPORT SYSTEMS

TYCEUCLUP 0311

UNISTRUT

- GB** Angle fittings 90°
- NL** Gebogen hulpstukken 90°
- F** Pièces de raccordements 90°

- D** Winkelverbinder 90°
- N** Konstruksjonsdeler 90°
- S** Vinkelfästen 90°

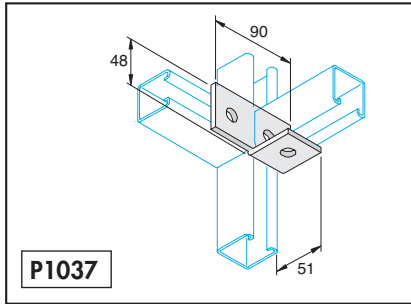

P1037	P1037SS	0,250	25

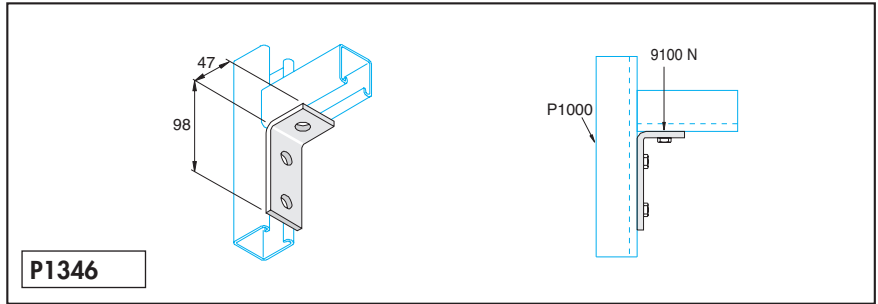

P1346	P1346SS	0,240	25

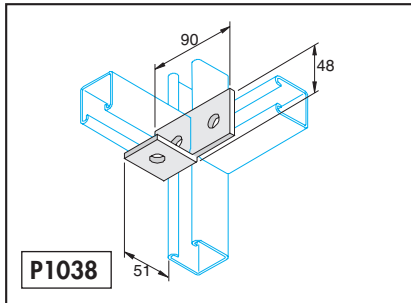

P1038	0,250	25

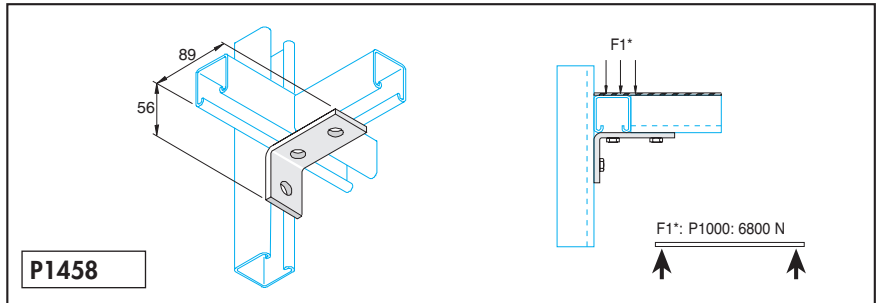

P1458	P1458SS	0,240	25

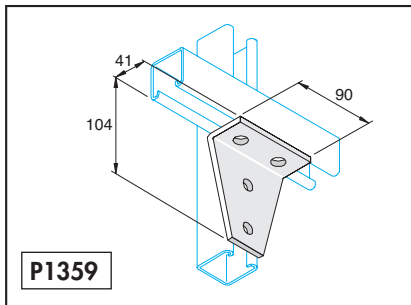

P1359	P1359SS	0,450	10

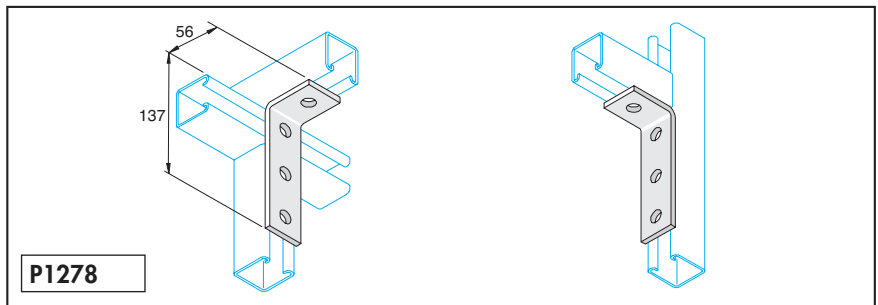

P1278	P1278SS	0,311	25

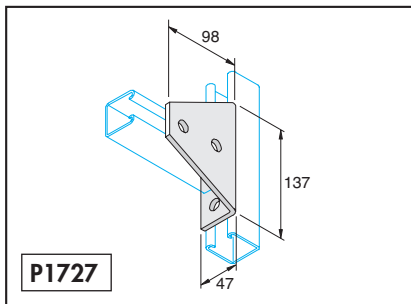

P1727	P1727SS	0,650	10

SUPPORT SYSTEMS

TYCEUUPSUP 0311

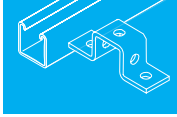

UNISTRUT

Schienenfuß & Kreuzverbindungswinkel **D**
 Fotplater og vingefittings **N**
 Fotstöd & fästdetaljer **S**

Channel base fittings & wing fittings **GB**
 Voetplaten & speciale hulpstukken **NL**
 Embases & pièces de raccordement **F**

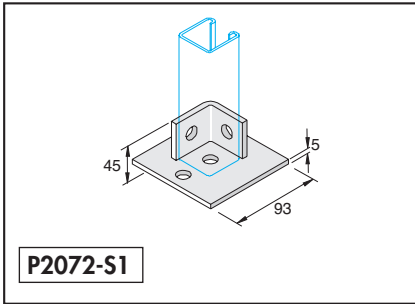

3	4	🔒	📦
P2072-S1	P2072S1SSP	0,575	10

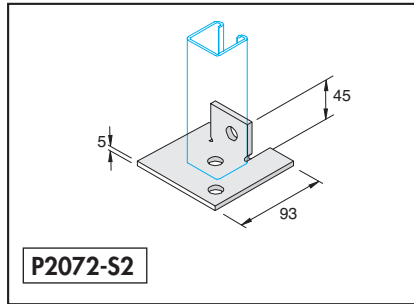

3	4	🔒	📦
P2072-S2	P2072S2SS	0,393	25

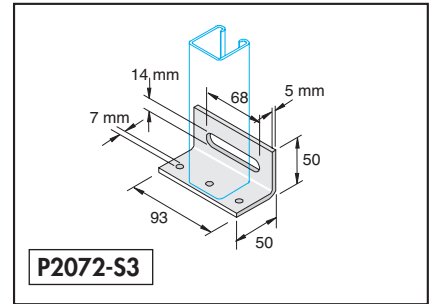

3	🔒	📦
P2072-S3	0,314	25

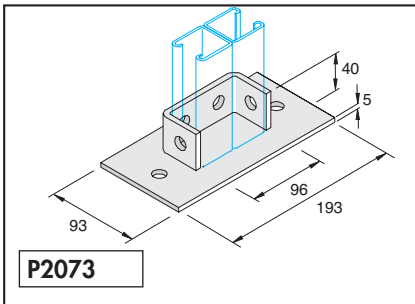

3	4	🔒	📦
P2073	P2073SSP	1,093	6

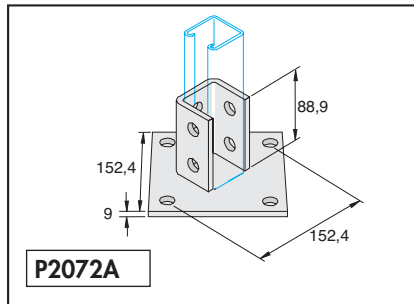

3	4	🔒	📦
P2072A	P2072ASSP	0,210	1

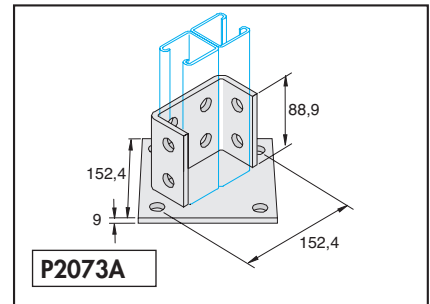

3	4	🔒	📦
P2073A	P2073ASSP	0,246	1

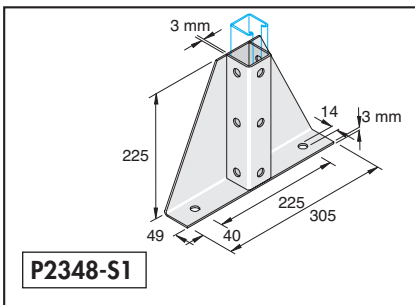

3	4	🔒	📦
P2348-S1	P2348S1SSP	2,209	1

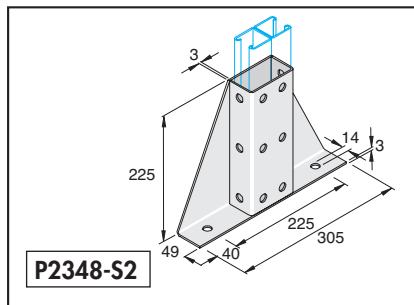

3	4	🔒	📦
P2348-S2	P2348S2SSP	2,438	1

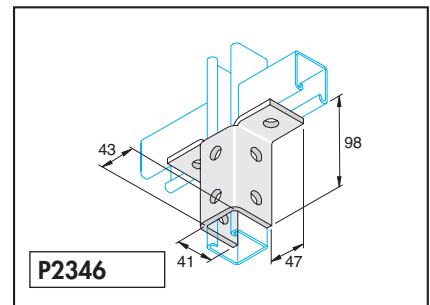

3	4	🔒	📦
P2346	P2346SS	0,662	10

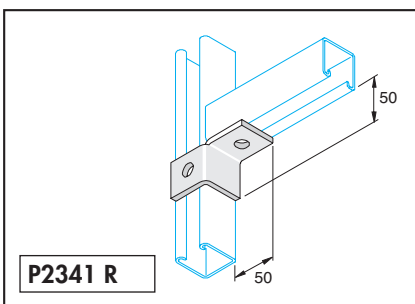

3	4	🔒	📦
P2341R	P2341RSS	0,240	25

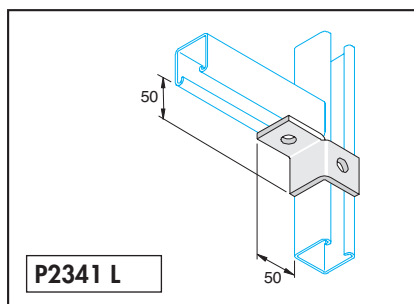

3	4	🔒	📦
P2341L	P2341LSS	0,240	25

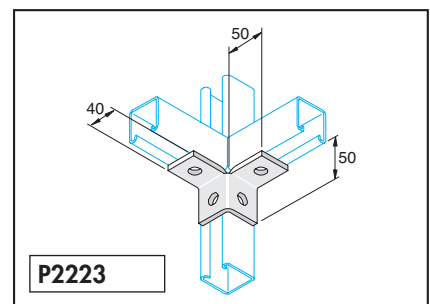

3	4	🔒	📦
P2223	P2223SS	0,317	25

SUPPORT SYSTEMS

TYCEUCLUSUP 0311

UNISTRUT

- GB** U and Z fittings & channel couplers
- NL** U en Z hulpstukken & koppelplaten
- F** Angles d'assemblages et éclisses

- D** Schienen-Klemmverbinder & Längstverbinder
- N** Konstruksjonsdeler og skjøter
- S** U och Z järn & kopplingfästen

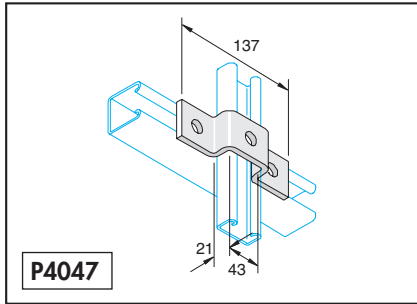

P4047	P4047SS	0,292	25

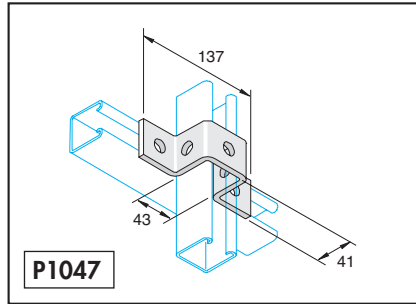

P1047	P1047SS	0,340	25

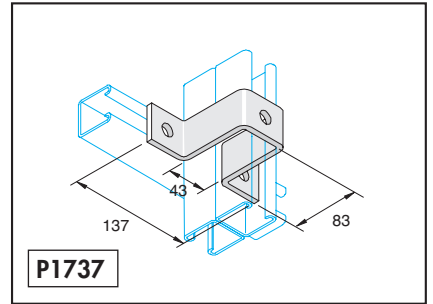

P1737	P1737SS	0,547	10

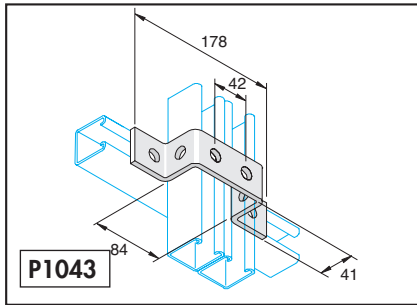

P1043	P1043SS	0,430	10

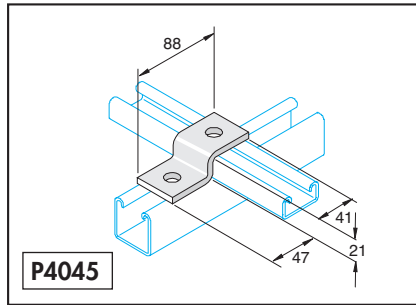

P4045	P4045SS	0,186	50

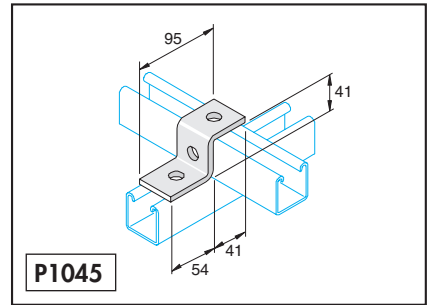

P1045	P1045SS	0,216	25

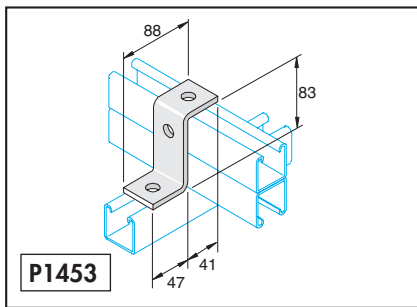

P1453	P1453SS	0,312	25

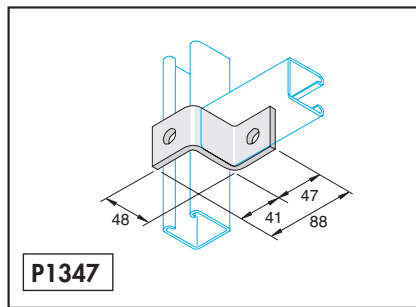

P1347	P1347SS	0,235	25

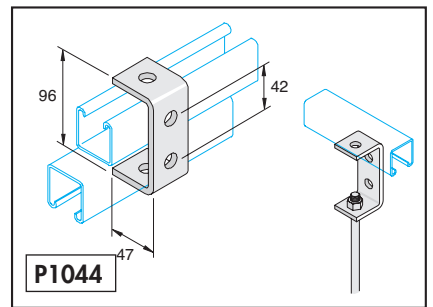

P1044	P1044SS	0,230	25

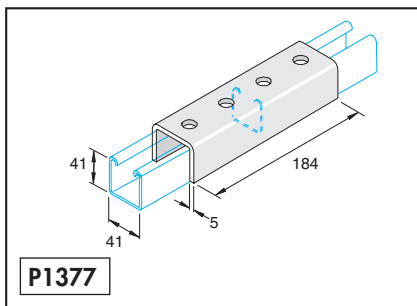

P1377	P1377SS	0,939	10

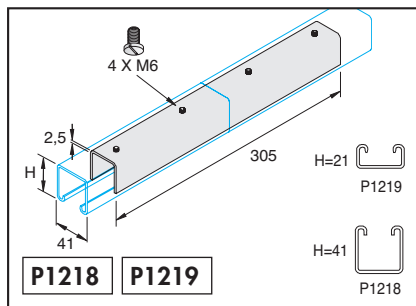

P1219	0,300	10	
P1218	0,519	10	

SUPPORT SYSTEMS

TYCEULSUP 0311

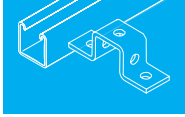

Schienenklemmbefestigung/Stahlträger **D**
 Bjelkeklemmer **N**
 Balkklammer **S**

Beam clamps **GB**
 Balkklemmen **NL**
 Crapauds **F**

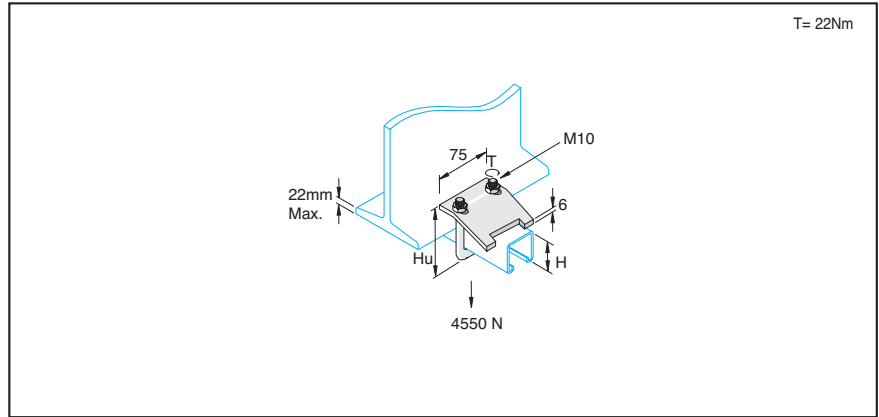

5	4	H mm	Hu mm	⚖️	📦
P2785	P2785SS	21 - 41	86	0,36	25
P2786	P2786SS	62 - 83	127	0,40	10
P2787	P2787SS	124	171	0,45	10
P2788	P2788SS	164	209	0,49	10

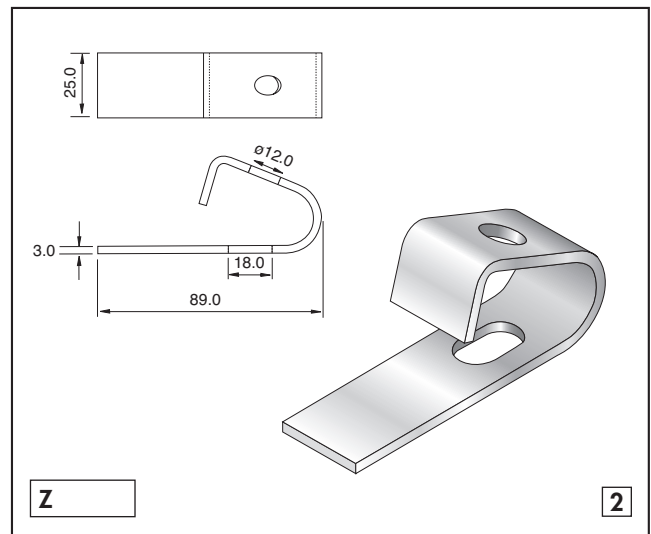
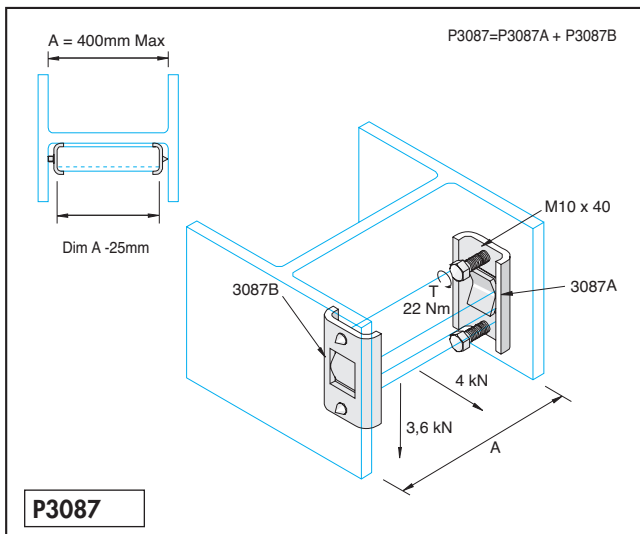

3	4	⚖️	📦
P3087	P3087SS	0,670	10

Art.-Nr.	⚖️ /100	📦
Z10	0,085	100

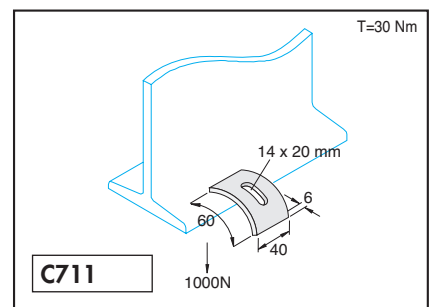
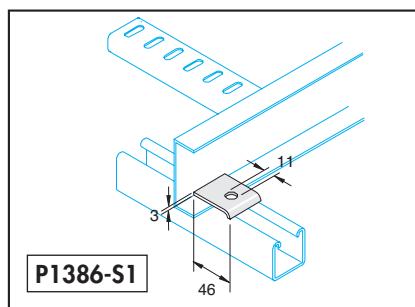
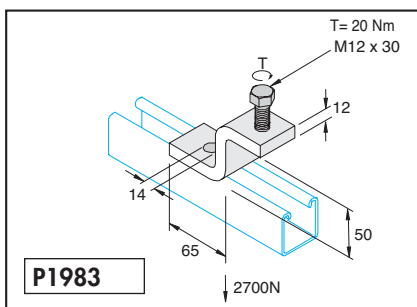

3	4	⚖️	📦
P1983	P1983SS	0,508	10

5	⚖️	📦
P1386-S1	0,042	100

3	4	⚖️	📦
C711	C711SS	0,112	50

SUPPORT SYSTEMS

TYCEUUPSUP 0311

UNISTRUT

- GB** Beam clamps
- NL** Balkklemmen
- F** Crapeuds

- D** Schienenklemmbefestigung/Stahlträger
- N** Bjelkeklemmer
- S** Balkklammer

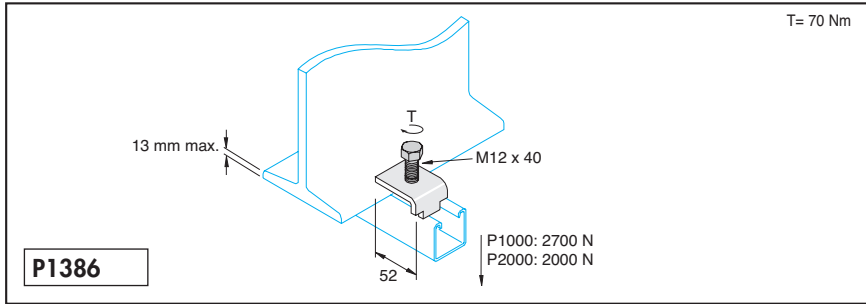

3	4	🔒	📦
P1386	P1386SS	0,042	50

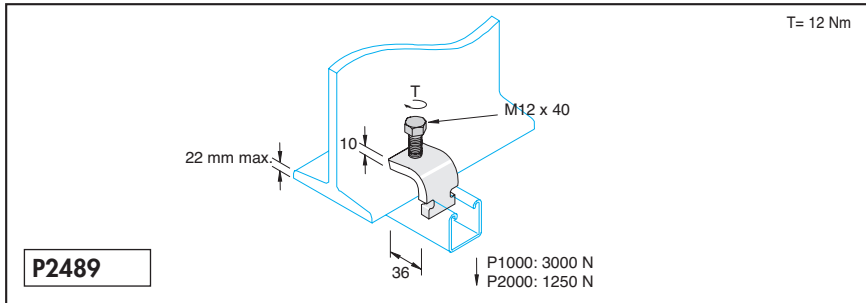

3	🔒	📦
P2489	0,220	25

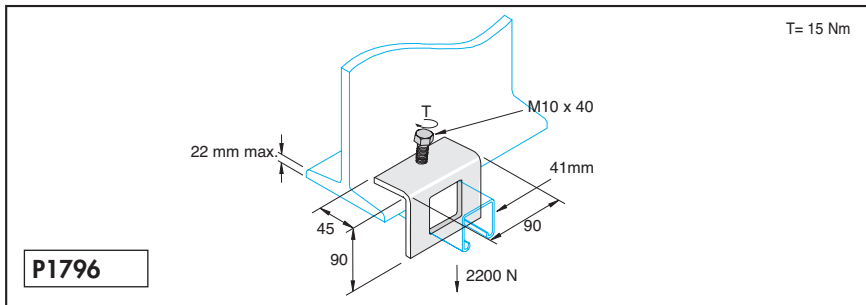

3	4	🔒	📦
P1796	P1796SS	0,430	10

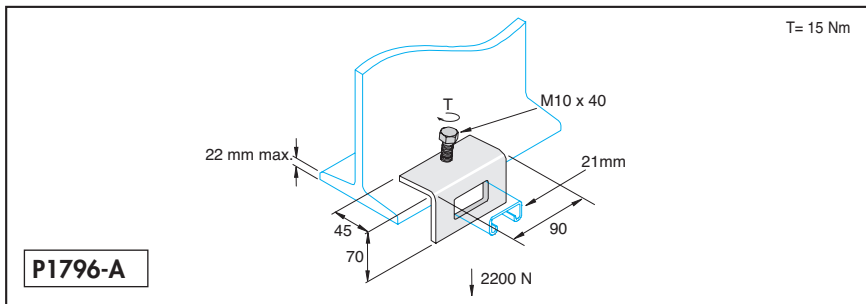

3	4	🔒	📦
P1796-A	P1796-ASS	0,390	10

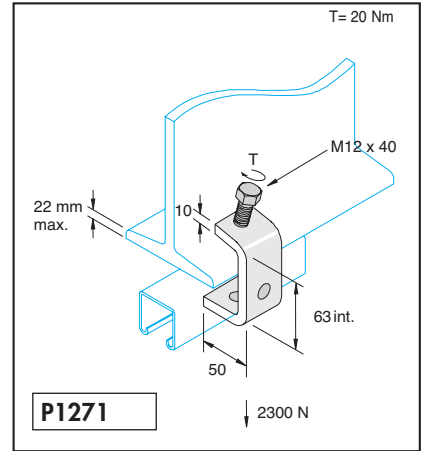

3	4	🔒	📦
P1271	P1271SS	0,477	10

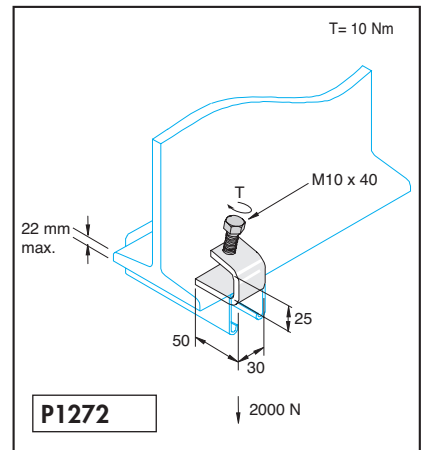

3	4	🔒	📦
P1272	P1272SS	0,137	50

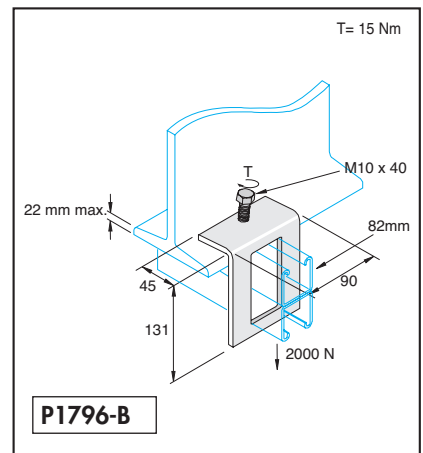

3	4	🔒	📦
P1796-B	P1796-BSS	0,430	10

SUPPORT SYSTEMS

TYCEULSUP 0311

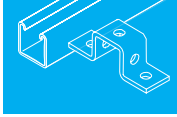

UNISTRUT

Schienenkonsolen **D** Konsoller **N** Konsoler **S**

Cantilever arms **GB** Konsoles **NL** Consoles **F**

Art. Nr.	P	h	L (mm)	Load diagrams			
				F_1	F_2	F_3	F_4
P2773T150	3	0,64	150	4,83 kN	2,41 kN	2,41 kN	1,61 kN
P2773T1505	5	0,64	150				
P2773T300	3	1,01	300	2,41 kN	1,21 kN	1,21 kN	0,80 kN
P2773T3005	5	1,01	300				
P2773T450	3	1,37	450	1,61 kN	0,80 kN	0,80 kN	0,54 kN
P2773T4505	5	1,37	450				
P2773T600	3	1,73	600	1,21 kN	0,60 kN	0,60 kN	0,40 kN
P2773T6005	5	1,73	600				

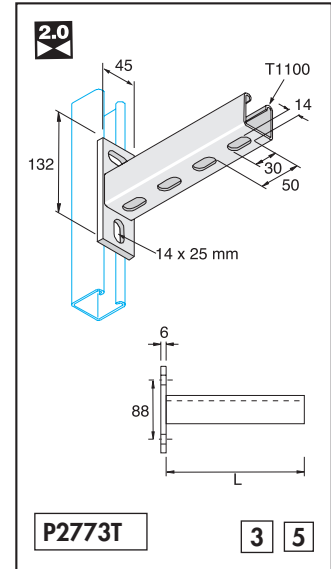

Art. Nr.	P	h	L (mm)	Load diagrams			
				F_1	F_2	F_3	F_4
P2663T150	3	0,96	150	6,12 kN	3,06 kN	3,06 kN	2,04 kN
P2663T1505	5	0,96	150				
2663T150SP	4	0,96	150				
P2663T300	3	1,30	300	3,06 kN	1,53 kN	1,53 kN	1,02 kN
P2663T3005	5	1,30	300				
2663T300SP	4	1,30	300				
P2663T450	3	1,74	450	2,04 kN	1,02 kN	1,02 kN	0,68 kN
P2663T4505	5	1,74	450				
2663T450SP	4	1,74	450				
P2663T600	3	2,06	600	1,53 kN	0,76 kN	0,76 kN	0,50 kN
P2663T6005	5	2,06	600				
2663T600SP	4	2,06	600				
P2663T750	3	2,30	750	1,22 kN	0,61 kN	0,61 kN	0,40 kN
P2663T7505	5	2,30	750				
2663T750SP	4	2,30	750				

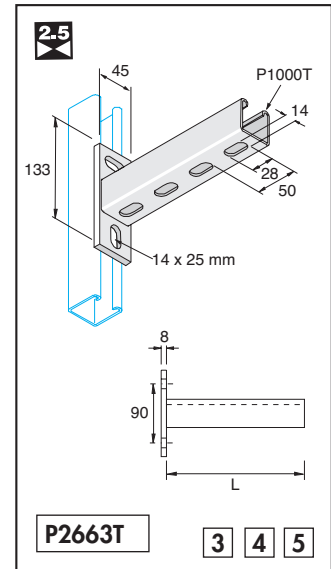

Art. Nr.	P	h	L (mm)	Load diagrams			
				F_1	F_2	F_3	F_4
P2668/150	3	0,80	150	6,20 kN	3,10 kN	3,10 kN	2,06 kN
P2668/300	3	1,17	300	3,20 kN	1,60 kN	1,60 kN	1,06 kN
P2668/450	3	1,59	450	2,15 kN	1,07 kN	1,07 kN	0,71 kN
P2668/600	3	2,03	600	1,62 kN	0,81 kN	0,81 kN	0,54 kN

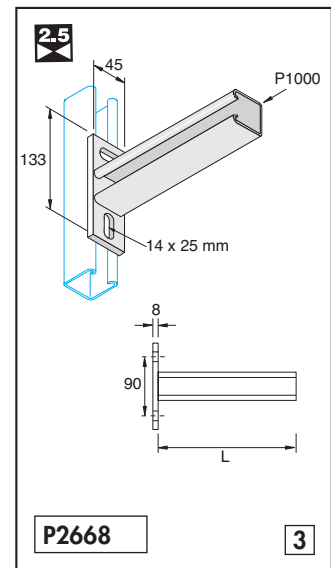

- Loadings indicated are only applicable when 2 cantilever arms are used. **GB**
- Belastinggegevens zijn van toepassing bij gebruik van 2 konsoles. **NL**
- Les charges indiquées sont données pour une installation minimum de 2 consoles. **F**
- Angegebene Belastungswerte sind nur gültig bei Einsatz von minimal zwei Konsolen **D**
- Angitte belastninger gjelder kun når 2 eller flere konsoller benyttes **N**
- Indikerade laster är endast applicerbara när två konsoler brukas. **S**

SUPPORT SYSTEMS

TYCEUCLUP 0311

UNISTRUT

- GB** Cantilever arms
- NL** Konsoles
- F** Consoles

- D** Schienenkonsolen
- N** Konsoller
- S** Konsoler

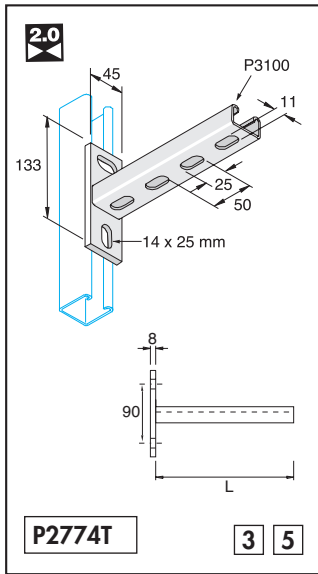

Art. Nr.	P		L (mm)				
P2774T150	3	0.47	150	1.94 kN	0.97 kN	0.97 kN	0.64 kN
P2774T1505	5	0.47	150				
P2774T300	3	0.70	300	1.00 kN	0.50 kN	0.50 kN	0.33 kN
P2774T3005	5	0.70	300				
P2774T450	3	0.94	450	0.67 kN	0.33 kN	0.33 kN	0.22 kN
P2774T4505	5	0.94	450				

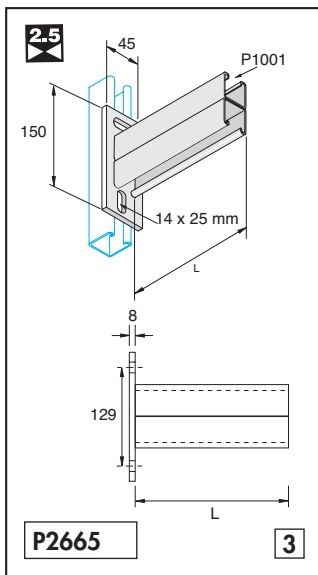

Art. Nr.	P		L (mm)				
P2665/150	3	1.57	150	8.82 kN	4.41 kN	4.41 kN	2.94 kN
P2665/300	3	3.26	300	6.47 kN	3.23 kN	3.23 kN	2.15 kN
P2665/450	3	4.02	450	4.31 kN	2.15 kN	2.15 kN	1.43 kN
P2665/600	3	4.98	600	3.23 kN	1.61 kN	1.61 kN	1.07 kN
P2665/750	3	5.83	750	2.58 kN	1.29 kN	1.29 kN	0.86 kN

SUPPORT SYSTEMS

TYCEUELSUP 0311

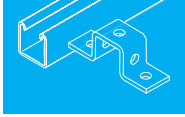

UNISTRUT

Unistrut Deckenkonsolen **D**
 Unistrut hengekonsoller med enkel skinne **N**
 Vertikala fästen med enkel skena **S**

Vertical support with single channel **GB**
 Hangkonsoles **NL**
 Pendart avec rail simple **F**

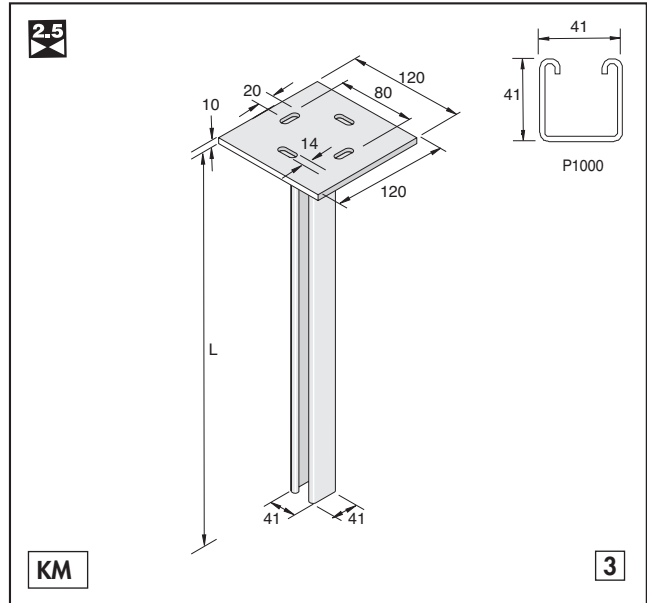

Art. Nr.	L (mm)	⚖️
KM 5003	500	2,50
KM 7503	750	3,10
KM 10003	1000	3,70
KM 12503	1250	4,30

Unistrut Deckenkonsolen mit Doppelschienen **D**
 Unistrut hengekonsoller med dobbel skinne **N**
 Vertikala fästen med dubbel skena **S**

Vertical support with double channel **GB**
 Hangkonsoles met dubbel profiel **NL**
 Pendart avec rail double **F**

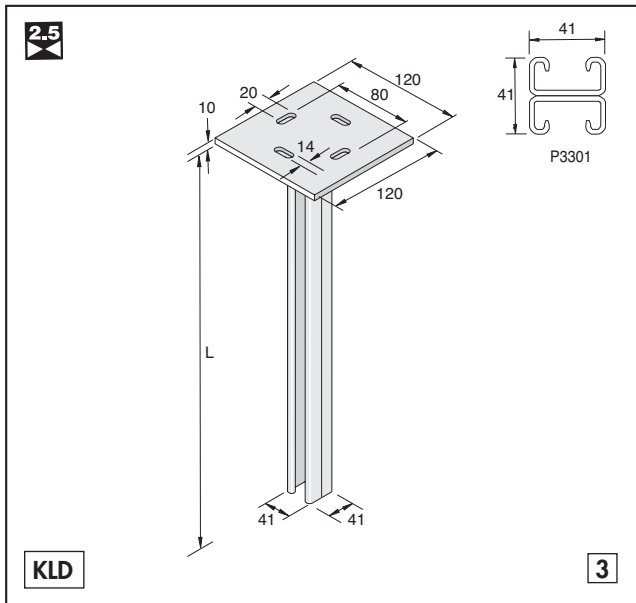

Art. Nr.	L (mm)	⚖️
KLD 5003	500	2,88
KLD 7503	750	3,82
KLD 10003	1000	4,76
KLD 12503	1250	5,68
KLD 15003	1500	6,64
KLD 20003	2000	8,52

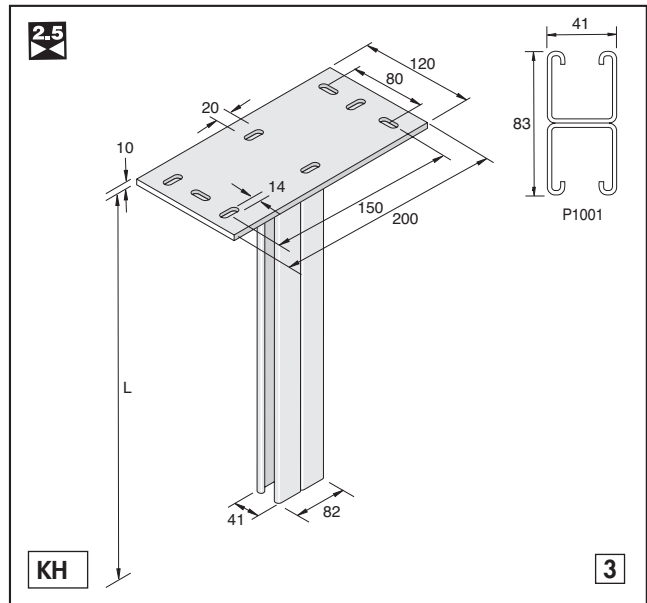

Art. Nr.	L (mm)	⚖️
KH 5003	500	4,50
KH 7503	750	6,25
KH 10003	1000	7,10
KH 12503	1250	7,95
KH 15003	1500	9,80
KH 20003	2000	12,50

SUPPORT SYSTEMS

TYCEUELSUP 0311

UNISTRUT

- GB** Channel trolley assemblies
- NL** Trolleys voor Unistrut profielen
- F** Supports à roulettes pour Rails Unistrut

- D** Schienen-Rollenlager / Schienenjustierbügel
- N** Ruller
- S** Hjulfåsten

+ 80° C

Nylon- White
Weiss
Blanc

$F1^*=400\text{ N}$

P1000

P2750/1 **0,068** **5**

$F1^*=230\text{ N}$

P1000

P2749 **0,023** **5**

P1000

RPM	kN
600	0,7
300	1,0
100	1,9

P2949 **0,200** **5**

P1000

RPM	F	kN
600	1,3	
300	2,0	
100	2,7	

P2950 **0,490** **5**

$F_{max}=5,4\text{ kN}$

P1834 **0,463** **3**

$F_{max}=11,3\text{ kN}$

P1834A **0,998** **3**



CABLE CLAMPS

- GB** Cable clamps & pvc blocks
- NL** Kabelklemmen & PVC beschermblokken
- F** Colliers pour cables et berceau en pvc

Art.Nr.	D ø (mm)	
CC1-08/12	08-12	0,027
CC1-12/16	12-16	0,031
CC1-16/20	16-20	0,036
CC1-20/24	20-24	0,041
CC1-24/28	24-28	0,045
CC1-28/32	28-32	0,060
CC1-32/36	32-36	0,068
CC1-36/40	36-40	0,076
CC1-40/44	40-44	0,096
CC1-44/48	44-48	0,095
CC1-48/52	48-52	0,107
CC1-52/56	52-56	0,112
CC1-56/60	56-60	0,158
CC1-64/70	64-70	0,190
CC1-70/76	70-76	0,240

Art.Nr.	D ø (mm)	
CC2-08/12	08-12	0,034
CC2-12/16	12-16	0,039
CC2-16/20	16-20	0,048
CC2-20/24	20-24	0,055
CC2-24/28	24-28	0,062

Art.Nr.	D ø (mm)	
GW10/12	10-12	0,012
GW14/16	14-16	0,016
GW18/20	18-20	0,026
GW22/24	22-24	0,028
GW26/28	26-28	0,032
GW30/32	30-32	0,040
GW34/36	34-36	0,044
GW38/40	38-40	0,057

Art.Nr.	D ø (mm)	
DW10/14	10-14	0,013
DW16/22	16-22	0,028
DW24/30	24-30	0,060

- D** Kabelschellen & PVC-Gegenwannen
- N** Kabelklammer og PVC underlag
- S** Kabelklammor & pvc klammor

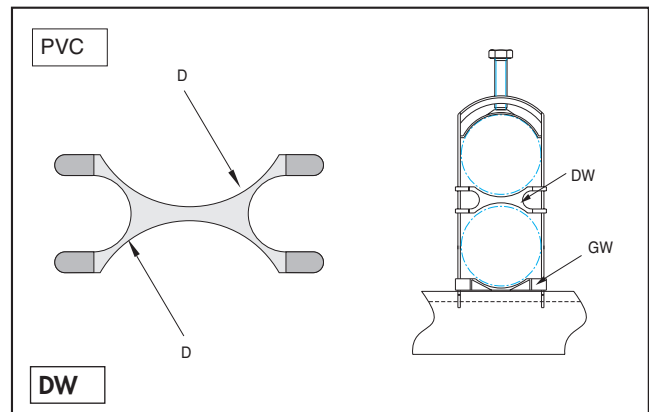
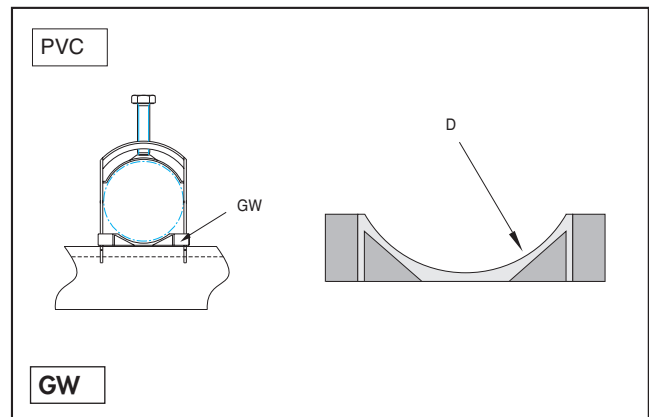
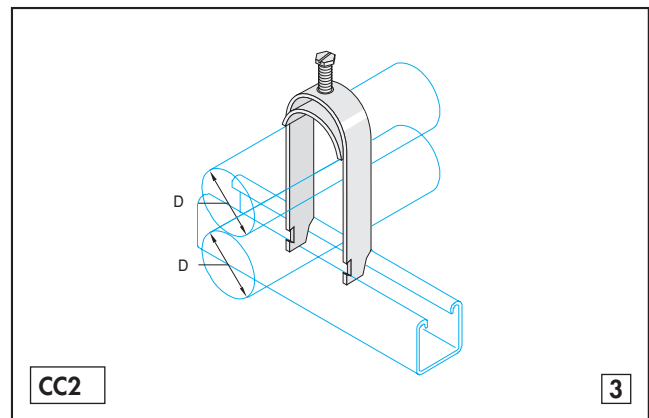
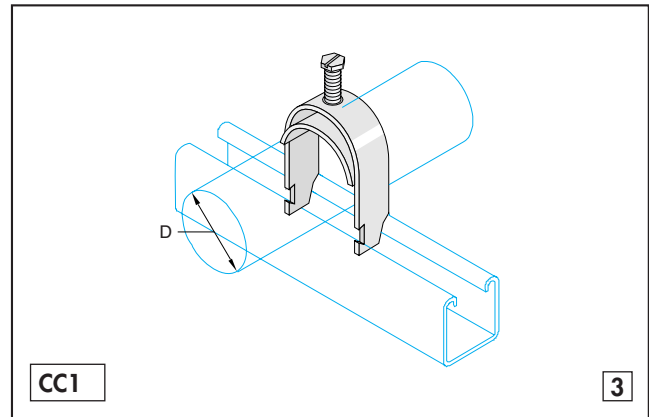



CABLE CLAMPS

Kabel- und Rohrschellen **D**

Kabelklammer **N**

Kabelklammer **S**

Cable- and Pipe clamps **GB**

Kabel- en buisklemmen **NL**

Colliers pour cables et tubes **F**

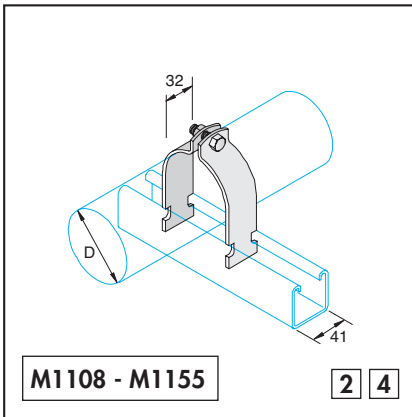

2 Art.nr.	4 Art.nr.	D mm	ρ g
M1108	M1108SS	8.7 - 10.3	35
M1109	M1109SS	10.3 - 12.7	37
M1110	M1110SS	11.9 - 13.5	38
M1111	M1111SS	13.5 - 14.3	39
M1112	M1112SS	14.3 - 16.7	40
M1113	M1113SS	15.9 - 18.3	41
M1114	M1114SS	18.3 - 20.6	45
M1115	M1115SS	19.0 - 21.4	47
M1116	M1116SS	21.4 - 25.4	49
M1117	M1117SS	25.4 - 27.8	53
M1118	M1118SS	27.0 - 30.2	64
M1119	M1119SS	30.2 - 33.8	72
M1120	M1120SS	31.8 - 35.9	72
M1121	M1121SS	34.9 - 39.7	79
M1122	M1122SS	39.7 - 42.9	84
M1123	M1123SS	42.9 - 46.8	90
M1124	M1124SS	46.8 - 50.8	128
M1125	M1125SS	48.4 - 52.4	131
M1126	M1126SS	52.4 - 58.7	137
M1127	M1127SS	58.7 - 63.5	150
M1128	M1128SS	63.5 - 68.3	160
M1129	M1129SS	68.3 - 73.0	164
M1130	M1130SS	73.0 - 79.4	171
M1131	M1131SS	76.2 - 82.6	175

2 Art.nr.	4 Art.nr.	D mm	ρ g
M1132	M1132SS	82.6 - 88.1	189
M1133	M1133SS	88.1 - 95.2	203
M1134	M1134SS	95.2 - 100.0	219
M1135	M1135SS	100.0 - 106.4	273
M1136	M1136SS	106.4 - 111.1	286
M1137	M1137SS	111.1 - 120.7	296
M1138	M1138SS	120.7 - 129.4	318
M1139	M1139SS	129.4 - 138.1	343
M1140	M1140SS	138.1 - 149.2	348
M1141	M1141SS	149.2 - 161.9	376
M1142	M1142SS	161.9 - 174.6	410
M1143	M1143SS	174.6 - 182.6	423
M1144	M1144SS	182.6 - 190.5	466
M1145	M1145SS	190.5 - 203.2	491
M1146	M1146SS	203.2 - 212.7	501
M1147	M1147SS	212.7 - 225.4	505
M1148	M1148SS	225.4 - 238.1	524
M1149	M1149SS	238.1 - 250.8	555
M1150	M1150SS	250.8 - 263.5	576
M1151	M1151SS	263.5 - 276.2	592
M1152	M1152SS	276.2 - 288.9	624
M1153	M1153SS	288.9 - 301.6	654
M1154	M1154SS	301.6 - 314.3	679
M1155	M1155SS	314.3 - 327.0	699

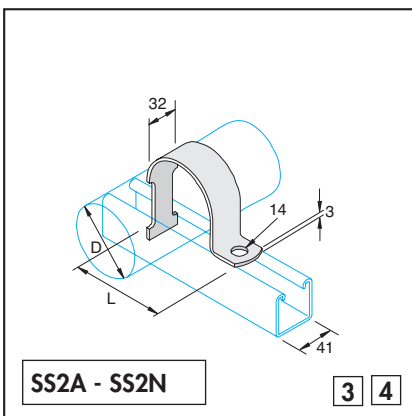

3 Art.nr.	4 Art.nr.	D NB/DN	D mm	L mm	ρ g
SS2/AH	SS2/ASS	15	- 21	66	59
SS2/BH	SS2/BSS	20	- 27	73	70
SS2/CH	SS2/CSS	25	- 34	81	84
SS2/DH	SS2/DSS	32	- 43	90	100
SS2/EH	SS2/ESS	40	- 48	96	112
SS2/FH	SS2/FSS	50	- 60	96	135
SS2/GH	SS2/GSS	65	- 76	113	165
SS2/HH	SS2/HSS	80	- 90	125	189
SS2/JH	SS2/JSS	90	- 102	137	214
SS2/KH	SS2/KSS	100	- 115	150	240
SS2/LH	SS2/LSS	125	- 140	175	287
SS2/MH	SS2/MSS	150	- 168	204	342
SS2/NH	SS2/NSS	200	- 220	255	442

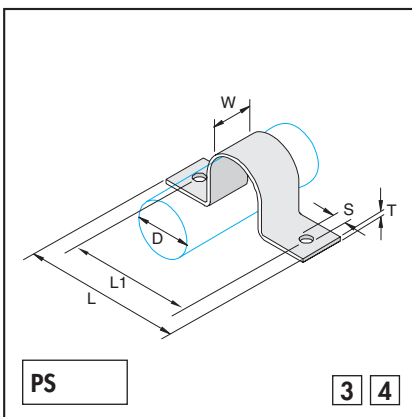

3 Art. No	4 Art. No	D NB/DN	D "	W x T mm	S mm	L mm	L1 mm
PS0153	PS0154	15	- 1/2"	40x3	11	108	68
PS0203	PS0204	20	- 3/4"	40x3	11	113	73
PS0253	PS0254	25	- 1"	40x3	11	120	80
PS0323	PS0324	32	- 1 1/4"	40x3	11	128	88
PS0403	PS0404	40	- 1 1/2"	40x3	11	134	94
PS0503	PS0504	50	- 2"	40x4	11	148	108
PS0653	PS0654	65	- 2 1/2"	40x4	11	164	124
PS0803	PS0804	80	- 3"	40x4	11	177	137
PS1003	PS1004	100	- 4"	40x4	14	202	162
PS1253	PS1254	125	- 5"	40x6	14	231	191
PS1503	PS1504	150	- 6"	40x6	14	260	220
PS2003	PS2004	200	- 8"	40x6	14	301	261
PS2503	PS2504	250	- 10"	50x6	18	385	335
PS3003	PS3004	300	- 12"	50x6	18	435	385

CABLE
CLAMPS



FIXINGS

GB Nuts , bolts & washers

NL Bouten, moeren & ringen

F Boulons, écrous & rondelles

M6	M8	M10	M12
933 [P] 6x12	933 [P] 8x20	933 [P] 10x20	933 [P] 12x22
933 [P] 6x16	933 [P] 8x25	933 [P] 10x25	933 [P] 12x25
933 [P] 6x20	933 [P] 8x30	933 [P] 10x30	933 [P] 12x30
933 [P] 6x25	933 [P] 8x35	933 [P] 10x40	933 [P] 12x40
933 [P] 6x30	933 [P] 8x40	933 [P] 10x50	933 [P] 12x50
933 [P] 6x35	933 [P] 8x45	933 [P] 10x60	933 [P] 12x60
933 [P] 6x40	933 [P] 8x50	933 [P] 10x80	933 [P] 12x80
933 [P] 6x60	933 [P] 8x60	933 [P] 10x100	933 [P] 12x100

P3300	P1000	
		
M10	M10	M12
17 AF/P3300	17 AF	19 AF

Art.Nr.	L mm	⚖ /100	
RFB 6x12	12	1,0	200
RFB 6x16	16	1,0	200
RFB 6x20	20	1,0	200
RFB 6x25	25	1,0	200
RFB 6x30	30	1,0	200
RFB 6x40	40	1,0	200
RFB 6x50	50	1,0	200
RFB 6x60	60	1,0	200

M6	M8	M10	M12	M16
934 [P] M6	934 [P] M8	934 [P] M10	934 [P] M12	934 [P] M16

M6	M8	M10	M12	M16
125 [P] M6	125 [P] M8	125 [P] M10	125 [P] M12	125 [P] M16

D Schrauben, Muttern & Unterlegscheiben

N Bolter, muttere & skiver

S Bult, mutter & brickor

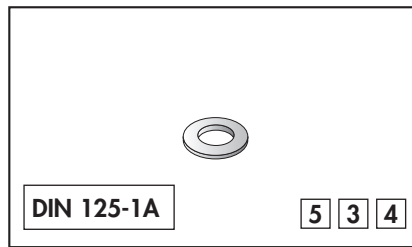
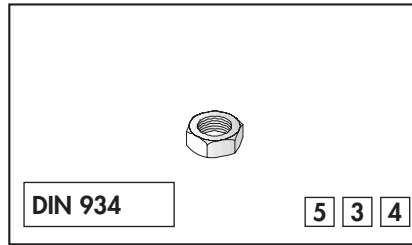
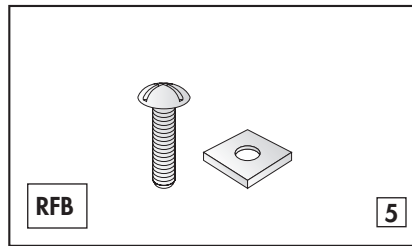
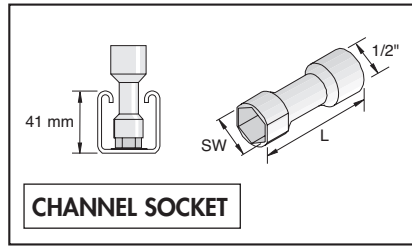
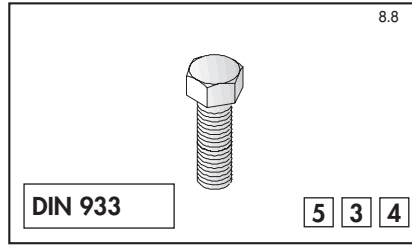

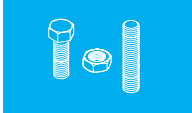

FIXINGS

Unterlegscheiben, Gewindestangen & Verbinder **D**

Skiver, gjengestag & skjøtemuttere **N**

Gängstång, bricker & långmutter **S**

Threaded rod, beam clamps & purlin clip **GB**

Draadstang & balkklemmen **NL**

Tige filetée et pinces **F**

DIN 9021 5 3 4

M6	M8	M10	M12	M16
9021 M6 (A=18 mm)	9021 M8 (A=24 mm)	9021 M10 (A=30 mm)	9021 M12 (A=36 mm)	9021 M16 (A=50 mm)

DIN 127B 5 3 4

M6	M8	M10	M12	M16
127 M6	127 M8	127 M10	127 M12	127 M16

DIN 975 5 4 3

4.6
L=1, 2 & 3 M L=1 M

M6	M8	M10	M12
975 M6x1M	975 M8x1M	975 M10x1M	975 M12x1M
975 M6x2M	975 M8x2M	975 M10x2M	975 M12x2M
975 M6x3M	975 M8x3M	975 M10x3M	975 M12x3M

DIN 6334 5 4

Art.Nr.	G	SW mm	L mm	
6334 M6	M6	10	18	50
6334 M8	M8	13	24	50
6334 M10	M10	17	30	50
6334 M12	M12	19	36	50
6334 M16	M16	24	48	50



PARTNUMBER INDEX

Art. Nr.		Art. Nr.		Art. Nr.		Art. Nr.		Art. Nr.		Art. Nr.	
125	8.000	AC312014	2.018	AC410046	2.008	AC510001	2.008	AC610047	2.009	B4MI30	5.001
127	8.000	AC312015	2.021	AC410047	2.008	AC510002	2.008	AC610048	2.009	B4MI60	5.001
17AF	8.000	AC312019	2.021	AC410048	2.008	AC510003	2.008	AC610049	2.009	B4MI130	5.001
19AF	8.000	AC312020	2.018	AC410049	2.008	AC510004	2.008	AC611001	2.010	B4MI160	5.001
2663	6.023	AC312021	2.018	AC411001	2.010	AC510005	2.008	AC611002	2.010	B4MI130	5.001
6334	8.001	AC312022	2.018	AC411002	2.010	AC510006	2.009	AC611003	2.010	B4MI160	5.001
9021	8.000	AC312023	2.018	AC411003	2.010	AC510007	2.009	AC611004	2.011	B4R30	5.000
933	8.000	AC312024	2.018	AC411004	2.011	AC510008	2.009	AC611005	2.011	B4R60	5.000
934	8.000	AC312030	2.020	AC411005	2.011	AC510009	2.009	AC611006	2.011	B4RB4530	5.000
975	8.001	AC312041	2.019	AC411006	2.011	AC510010	2.009	AC612009	2.021	B4RB4560	5.000
AC110001	2.008	AC312042	2.019	AC412009	2.021	AC510011	2.009	AC612015	2.021	B4RB9030	5.000
AC110002	2.008	AC312043	2.019	AC412011	2.018	AC510012	2.009	AC612019	2.021	B4RB9060	5.000
AC110003	2.008	AC312044	2.019	AC412012	2.018	AC510013	2.008	AC612065	2.017	B4RBOK9030	5.000
AC110004	2.008	AC312045	2.019	AC412013	2.018	AC510014	2.008	AC612066	2.017	B4RBOK9060	5.000
AC110005	2.008	AC312046	2.019	AC412014	2.018	AC510015	2.008	AC612067	2.017	B4S1430	5.002
AC110006	2.009	AC312065	2.017	AC412015	2.021	AC510016	2.008	AC612080	2.016	B4S1460	5.002
AC110007	2.009	AC312066	2.017	AC412019	2.021	AC510017	2.008	AC612081	2.016	base plates	6.019
AC110008	2.009	AC312067	2.017	AC412020	2.018	AC510018	2.008	AC612082	2.016	BB	5.002
AC110009	2.009	AC312080	2.016	AC412021	2.018	AC510019	2.008	AC612083	2.016	beam clamps	6.021
AC110010	2.009	AC312081	2.016	AC412022	2.018	AC510031	2.009	AC612089	2.017	bolt	8.000
AC110011	2.009	AC312082	2.016	AC412023	2.018	AC510037	2.009	AC619006	2.012	C711	6.021
AC110012	2.009	AC312083	2.016	AC412024	2.018	AC510039	2.009	AC619007	2.012	C711SS	6.021
AC110013	2.008	AC312089	2.017	AC412041	2.019	AC510040	2.009	AC619008	2.012	cable clamp	7.000
AC110014	2.008	AC312090	2.013	AC412042	2.019	AC510041	2.009	AC619009	2.012	cable tie adapter	3.007
AC110015	2.008	AC312091	2.013	AC412043	2.019	AC510042	2.009	AC619010	2.012	cantilever arms	6.023
AC110016	2.008	AC319	2.012	AC412044	2.019	AC510044	2.008	AC619011	2.012	CC1	7.000
AC110017	2.008	AC334053	2.015	AC412045	2.019	AC510046	2.008	AC619012	2.012	channel	6.005
AC110018	2.008	AC335009	2.015	AC412046	2.019	AC510047	2.008	AC619021	2.012	channel	6.005
AC110019	2.008	AC335010	2.015	AC412065	2.017	AC510048	2.008	adapter	8.001	channel socket	8.000
AC110021	2.009	AC335019	2.015	AC412066	2.017	AC510049	2.008	allthread	8.001	channelnuts	6.011
AC110037	2.009	AC335020	2.015	AC412067	2.017	AC602069	2.017	angle fittings	6.016	double clamp	7.001
AC110039	2.009	AC402609	2.017	AC412080	2.016	AC610001	2.008	arms	6.023	drop out	3.007
AC110040	2.009	AC410001	2.008	AC412081	2.016	AC610002	2.008	B/EO	5.003	DW	7.001
AC110041	2.009	AC410002	2.008	AC412082	2.016	AC610003	2.008	B/K/PVC	5.003	fish plate coupler	1.002
AC110042	2.009	AC410003	2.008	AC412083	2.016	AC610004	2.008	B3FB	5.001	fittings	6.014
AC110044	2.008	AC410004	2.008	AC412089	2.017	AC610005	2.008	B3FW30	5.002	flat fittings	6.014
AC110046	2.008	AC410005	2.008	AC413009	2.013	AC610006	2.009	B3FW60	5.002	gutter bolts	8.000
AC110047	2.008	AC410006	2.009	AC413010	2.013	AC610007	2.009	B3KM30	5.000	GW	7.000
AC110048	2.008	AC410007	2.009	AC413011	2.013	AC610008	2.009	B3KM60	5.000	hammer head bolts	6.013
AC110049	2.008	AC410008	2.009	AC413012	2.013	AC610009	2.009	B3LC30	5.002	HB	1.011
AC113009	2.013	AC410009	2.009	AC419006	2.012	AC610010	2.009	B3LC60	5.002	HB	1.011
AC113010	2.013	AC410010	2.009	AC419007	2.012	AC610011	2.009	B3LM	5.001	HER	1.013
AC113011	2.013	AC410011	2.009	AC419008	2.012	AC610012	2.009	B3M	5.001	HER	1.013
AC113012	2.013	AC410012	2.009	AC419009	2.012	AC610013	2.008	B3R30	5.000	hex head bolt	8.000
AC211001	2.010	AC410013	2.008	AC419010	2.012	AC610014	2.008	B3R60	5.000	hex nuts	8.000
AC211002	2.010	AC410014	2.008	AC419011	2.012	AC610015	2.008	B3RB4530	5.000	HFR	1.012
AC211003	2.010	AC410015	2.008	AC419012	2.012	AC610016	2.008	B3RB4560	5.000	HIR	1.013
AC211004	2.011	AC410016	2.008	AC419021	2.012	AC610017	2.008	B3RB9030	5.000	HL	1.010
AC211005	2.011	AC410017	2.008	AC432041	2.014	AC610018	2.008	B3RB9060	5.000	HSC	1.010
AC211006	2.011	AC410018	2.008	AC432042	2.014	AC610019	2.008	B3RBOK9030	5.000	HT	1.011
AC302069	2.017	AC410019	2.008	AC432044	2.014	AC610020	2.012	B3RBOK9060	5.000	HWC	1.010
AC310020	2.012	AC410020	2.012	AC432052	2.014	AC610021	2.012	B4FB	5.001	HX	1.011
AC310021	2.012	AC410021	2.012	AC432053	2.014	AC610023	2.012	B4FB60	5.001	KH	6.025
AC310023	2.012	AC410023	2.012	AC432054	2.014	AC610031	2.009	B4FW30	5.002	KL	6.025
AC311004	2.010	AC410031	2.009	AC432055	2.014	AC610037	2.009	B4FW60	5.002	KLD	6.025
AC312002	2.020	AC410037	2.009	AC432056	2.014	AC610039	2.009	B4KM30	5.000	KM	6.025
AC312003	2.020	AC410039	2.009	AC434053	2.015	AC610040	2.009	B4KM60	5.000	large washer	8.001
AC312009	2.021	AC410040	2.009	AC435009	2.015	AC610041	2.009	B4LC30	5.002	LB	1.003
AC312011	2.018	AC410041	2.009	AC435010	2.015	AC610042	2.009	B4LC60	5.002	LB	1.003
AC312012	2.018	AC410042	2.009	AC435019	2.015	AC610044	2.009	B4LM30	5.001	LER	1.005
AC312013	2.018	AC410044	2.008	AC435020	2.015	AC610046	2.009	B4LM60	5.001	LIR	1.005



PARTNUMBER INDEX

Art. Nr.		Art. Nr.		Art. Nr.		Art. Nr.		Art. Nr.	
LL	1.002	P1063	6.014	P2774T	6.024	U106	3.001	UTEE	3.006
LPF	1.002	P1064	6.014	P2785	6.021	U10B	3.002	UTSL	3.007
LT	1.003	P1065	6.014	P2786	6.021	U10HDB	3.006	UTSS	3.007
LX	1.003	P1066	6.014	P2787	6.021	U10HSP	3.006	UW	6.014
M10X100SN	6.013	P1067	6.014	P2788	6.021	U10I	3.004	UWC	3.007
M10X30SN	6.013	P1068	6.017	P2815S	6.016	U10O	3.004	vertical support	6.025
M10X40SN	6.013	P1074	6.016	P2949	6.026	U10RED	3.007	washer	8.000
M10X50SN	6.013	P1111...	6.002	P2950	6.026	U10SC	3.006	WIRECUTTER	2.011
M10X60SN	6.013	P1186	6.016	P3087	6.021	U10SP	3.006		
M10X75SN	6.013	P1218	6.020	P3100	6.000	U10T	3.003		
M12X100SN	6.013	P1219	6.020	P3111...	6.000	U10TEC	3.006		
M12X30SN	6.013	P1271	6.022	P3270	6.016	U10VSP	3.006		
M12X40SN	6.013	P1272	6.022	P3300	6.001	U10X	3.003		
M12X50SN	6.013	P1278	6.018	P3301	6.006	U123	3.001		
M12X60SN	6.013	P1325	6.017	P3311...	6.001	U126	3.001		
M12X75SN	6.013	P1326	6.017	P3321...	6.006	U12B	3.002		
M16X102SN	6.013	P1346	6.018	P3370	6.010	U12HDB	3.006		
M16X63SN	6.013	P1347	6.020	P4000	6.000	U12HSP	3.006		
M6X30SN	6.013	P1354	6.016	P4011...	6.000	U12I	3.004		
M8X100SN	6.013	P1358	6.015	P4045	6.020	U12O	3.004		
M8X30SN	6.013	P1359	6.018	P4047	6.020	U12RED	3.007		
M8X40SN	6.013	P1377	6.020	P5000	6.004	U12SC	3.006		
M8X50SN	6.013	P1386	6.022	P5001	6.007	U12SP	3.006		
M8X60SN	6.013	P1386-S1	6.021	P501....	6.004	U12T	3.003		
M8X75SN	6.013	P1453	6.020	P502....	6.007	U12TEC	3.006		
MB	1.007	P1458	6.018	P5500	6.004	U12VSP	3.006		
MB	1.007	P1546	6.016	P5501	6.007	U12X	3.003		
MER	1.009	P1580	6.015	P551....	6.004	U153	3.001		
MFR	1.004	P1727	6.018	P552....	6.007	U156	3.001		
MFR	1.008	P1737	6.020	P8000	6.005	U15B	3.002		
MIR	1.009	P1796	6.022	P801....	6.005	U15HDB	3.006		
ML	1.006	P1796	6.022	P802....	6.008	U15HSP	3.006		
MSC	1.006	P1834	6.026	penny washer	8.001	U15I	3.004		
MT	1.007	P1941	6.014	PNL	6.011	U15O	3.004		
MWC	1.006	P1983	6.021	PNP	6.011	U15RED	3.007		
MX	1.007	P2011...	6.002	PNS	6.011	U15SC	3.006		
NBM103	4.001	P2072	6.019	RFB6	8.000	U15SP	3.006		
NBPM10	3.007	P2073	6.019	rod	8.001	U15T	3.003		
NBPM6	2.010	P2073	6.019	rod connector	8.001	U15TEC	3.006		
NCT75TB	3.007	P2095	6.016	roofing nut & bolt	8.000	U15VSP	3.006		
nut	8.000	P2097	6.016	socket	8.000	U15X	3.003		
nut load data	6.007	P2101	6.016	spring washer	8.001	UANGLE	3.006		
Nylon	6.026	P2103	6.016	stand off bracket	1.015	UCLAMP	3.006		
OCB	1.015	P2106	6.016	strut	6.000	UCLIP3	3.006		
open c bracket	1.015	P2108	6.016	stud	8.001	UCUR	3.007		
P1000	6.003	P2223	6.019	stud connector	8.001	UDIV	3.007		
P1001	6.006	P2322	6.015	t-bolts	6.013	UDO	3.007		
P101....	6.003	P2341L	6.019	thermal spacer	3.007	UES	3.007		
P102....	6.006	P2341R	6.019	threaded rod	8.001	UHDC3	3.006		
P1026	6.017	P2346	6.019	tray arms	1.015	UMP3	3.007		
P103....	6.006	P2348	6.019	tray cover	1.014	URB3	3.007		
P1031	6.015	P2484	6.017	trolley supports	6.026	USL	4.000		
P1033	6.017	P2489	6.022	trolleys	6.026	USLB	4.000		
P1036	6.015	P2491	1.015	T1100	6.002	USLDIV	4.001		
P1037	6.018	P2631	6.024	T2000	6.002	USLE	4.000		
P1038	6.018	P2663	6.023	TU/ES100	1.014	USLHB3	4.001		
P1043	6.020	P2665	6.024	TUB	5.002	USLHDC3	4.001		
P1044	6.020	P2668	6.023	TUSB	1.015	USLR	4.000		
P1045	6.020	P2749	6.026	U COVER	3.007	USLSC	4.001		
P1047	6.020	P2750/1	6.026	U COVER CLIP	3.007	USLT	4.000		
P1062	6.014	P2773T	6.023	U103	3.001	USLVC	4.001		

tyco
Fire Protection Products

Headoffices:

Worldwide:

USA
Lansdale (PA)
Tel: + 1 215-362-0700
Fax: + 1 215-362-5385

Regional offices:

Europe / Middle East /
Africa (EMEA)
The Netherlands
Enschede
Tel.: +31 (0)53 4284444
Fax: +31 (0)53 4283377

Asia
Singapore
Tel: + 65 6861 1655
Fax: + 65 6861 1312

Subsidiaries EMEA

Austria
(Vienna)
Tel: +43 (0)1 2710049
Fax: +43 (0)1 2710142

Belgium
(Mechelen)
Tel: +32 (0)15 285555
Fax: +32 (0)15 206076

France
(Paris)
Tel: +33 (0)1 48178727
Fax: +33 (0)1 48178720

Germany
(Rodgau)
Tel: +49 (0)6106 84455
Fax: +49 (0)6106 18177

Hungary
(Budapest)
Tel: +36 (0)1 4811383
Fax: +36 (0)1 2034427

Italy
(Nerviano)
Tel: +39 0331 583000
Fax: +39 0331 583030

The Netherlands
(Enschede)
Tel: +31 (0)53 4284444
Fax: +31 (0)53 4283377

Norway
(Lørenskog)
Tel: +47 67 917700
Fax: +47 67 917715

Spain
(Madrid)
Tel: +34 91 3807460
Fax: +34 91 3807461

Sweden
(Lammhult)
Tel: +46 (0)472 269980
Fax: +46 (0)472 269989

United Arab Emirates
(Dubai)
Tel: +971 48838689
Fax: +971 48838674

United Kingdom & Ireland
(Manchester)
Tel: +44 (0)161 8750400
Fax: +44 (0)161 8750491